

# Arboricultural Report

Mr Denis Lambert

Spout Farm

Preston Road

Longridge



PR3 3BE

June 2016

U R B A N  
G R E E N



## Quality Management

<b>Job No</b>	10399		
<b>Project</b>	Spout Farm		
<b>Location</b>	Spout Farm, Preston Road, Longridge, PR3 3BE		
<b>Title</b>	Arboricultural Report AIA & AMS		
<b>Document Type</b>	BS 5837	<b>Issue</b>	2
<b>Date</b>	14 <sup>th</sup> June 2016		
<b>Prepared by</b>	Natasha Seaward	Signature (for file)	
<b>Checked by</b>	Joshua Corbett	Signature (for file)	

## Revision Status / History

Rev	Date	Issue / Purpose / Comment	Prepared	Checked
2	14/06/16	Drawings and report amended to client comments	NS	JC

## Contents

1	Introduction .....	2
1.1	Instructions and references .....	2
1.2	Scope and limitations of the report .....	2
2	Site Overview.....	4
2.1	Location .....	4
2.2	Tree condition and recommendations .....	4
2.3	Summary of findings .....	5
2.4	Work priority and future management .....	5
2.5	Tree protection status.....	5
2.6	Tree protection – general advice.....	5
2.7	Tree works .....	6
2.8	Wildlife .....	6
3	Arboricultural Impact Assessment (AIA) .....	7
3.1	Summary of the development .....	7
3.2	Tree constraints .....	7
3.3	Impact of tree loss.....	7
3.4	Impact of demolition activities.....	7
3.5	Impact of general construction activity .....	7
3.6	Changes in ground surfaces .....	7
4	Arboricultural Method Statement (AMS) .....	8
4.1	Summary of the impacts identified .....	8
4.2	Development implementation phases .....	8
4.3	Phase 1 – Site preparation .....	8
4.4	Tree surgery works .....	8
4.5	General construction activity .....	9
4.6	Potential damage to above ground parts of retained trees	9
4.7	Protective fencing.....	9
4.8	Pre-development inspection.....	10
4.9	Phase 2 – Construction process.....	11
4.10	RPAs explained.....	11
4.11	Construction Exclusion Zone (CEZ).....	11
4.12	Working in the RPA .....	11
4.13	Demolition in the RPA .....	11
4.14	Temporary site cabins.....	12
4.15	Utilities.....	12
4.16	Excavation in the RPA (applicable to G28) .....	12
4.17	New structures and surface design in the RPA (applicable to G28) .....	13
4.18	Changes in ground level .....	13
4.19	Boundary treatments .....	13
4.20	Soft landscaping .....	14
4.21	Monitoring.....	14
4.22	Phase 3 – Post development .....	14
4.23	Removal of protective fencing and signing off .....	14
	Appendix 1 - Tree Data Schedule .....	15
	Appendix 2 – Tree Schedule Definition of Terms.....	16
	Appendix 3 – Site Plans.....	18

# 1 Introduction

## 1.1 Instructions and references

All trees, regardless of their statutory status, are a material consideration in a planning application. It is therefore essential that the potential effects of any Proposed Development on existing trees are fully assessed.

We have been instructed by Mr Dennis Lambert carry out an Arboricultural Survey to British Standard 5837:2012 guidelines at the site location and produce our findings in a report. We have also been instructed to provide an Arboricultural Impact Assessment to evaluate the impact on trees present and an Arboricultural Method Statement to provide detailed guidance on the protection of retained trees throughout the construction process.

A scaled plan has been provided with tree positions already plotted. Any extra trees found on site that were not included on the original plan have been plotted according to measurements taken on site and/or by the use of satellite imagery.

A plan outlining the development proposals has been used to form the basis of the Arboricultural Impact Assessment.

## 1.2 Scope and limitations of the report

The report is designed to accompany a planning application following guidance set out in BS 5837:2012 Trees in relation to design, demolition and construction - Recommendations.

The Arboricultural Impact Assessment (AIA) will appraise the Proposed Development in relation to its effect on surveyed

trees and any potential impact on local amenity by appraising the following:

- General construction operations.
- Soil compaction in Root Protection Areas (RPAs).
- Installation of hard services including drives and paths.
- Potential physical damage to roots, stems and aerial parts of trees.
- Removal or pruning of trees.

The impact assessment will also appraise the effect that the retained trees may have on the development such as potential nuisance caused by excessive leaf/fruit litter, lighting levels within the proposed building and grounds and the potential damage to structures.

The Arboricultural Method Statement (AMS) is designed to advise on tree management and protection during the planning process.

All processes that have the potential to impact on trees should be considered in the wider project management of the site. This can be done by instructing an arboricultural consultant as part of the management team. This will ensure that any works that can affect trees will be monitored and supervised throughout the project.

The report is based upon a visual inspection. The consultant shall not be responsible for events that happen after the date of the report due to factors that were not apparent at the time, and the acceptance of this report constitutes an agreement with the guidelines and the terms listed in this report.

Any defects seen by a contractor or the employer that were not apparent to the consultant must be brought to the consultant's attention immediately.

The consultant accepts no liability in respect of the trees unless the recommendations of this report are carried out under his supervision.

Any physical alterations to site conditions subsequent to this report may have the potential to change/invalidate the findings and recommendations of this report.

Assessing the potential influence of trees upon load bearing soils, beneath existing and proposed structures resulting from water abstraction by trees or rehydration of shrinkable soils was not included in the contract brief and is therefore not considered in the report. The consultant cannot be held responsible for damage arising from such action.

Trees have the potential to cause indirect damage to existing and proposed structures by desiccation of the soil. Where soils are suspected to be shrinkable, they should be analysed by laboratory testing to determine the plasticity index. This will allow management decisions to be made relating to foundation depths, new planting and the effect of tree removals.

Potentially hazardous trees are highlighted and appropriate recommendations are made. However, this report should not be seen as a substitute for a full tree risk assessment or management plan which are specifically designed to minimise risk and liability associated with responsibility for trees.

## 2 Site Overview

### 2.1 Location

The site is situated in a rural area close to Longridge (Figure 1). The OS reference is SD 6027336026.

The survey was limited to the area shown in Figure 2 which is sufficient to consider the impact of the proposals.

Figure 1

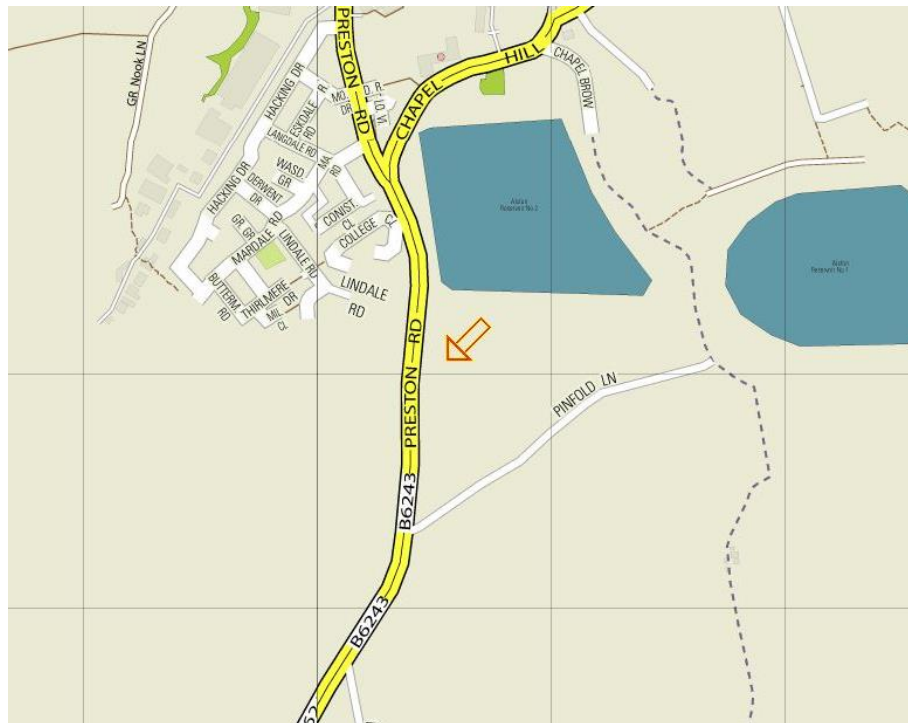

Figure 2



### 2.2 Tree condition and recommendations

The recommendations found in the Tree Data Schedule in Appendix 1 are based on assessments from a health and safety perspective and are made regardless of the Proposed Development. For details regarding trees in relation to the proposed development please refer to the Arboricultural Impact Assessment.

## 2.3 Summary of findings

Trees on site are generally semi-mature and include hornbeam, beech, London plane, horse chestnut and elm. They are generally confined to the site boundaries and are all of either low or moderate value.

All trees on site are deemed to be in an acceptable condition and no further works have been recommended.

## 2.4 Work priority and future management

The following table suggests a schedule for prioritising works required to individual specimens, as outlined in the Tree Data Schedule in Appendix 1, in order to ensure that the associated risks are abated:

Priority	Definition	Tree Number
<b>Urgent</b>	As soon as possible	None
<b>Very High</b>	Within 1 Month	None
<b>High</b>	Within 3 Months	None
<b>Moderate</b>	Within 1 year	None
<b>Low</b>	Within 3 years	None

Upon completion of any recommended works, the trees will be in an acceptable condition from a health and safety perspective. However, it is recommended they are regularly monitored with an inspection frequency of three years.

Inspection Frequency (years)	Tree Number
<b>0.5</b>	None
<b>1</b>	None
<b>1.5</b>	None
<b>3</b>	T1, T2, T3, T4, T5, H6, G7, H8, G9, T11, T12, H13, G14, T15, G16, T17, T18, G19, H20, T21, G22, T23, G24, T25, T26, T27, G28, G29

## 2.5 Tree protection status

At the time of writing the report, we have not yet received a response from Ribble Valley Borough Council to our request regarding the status of trees on or adjacent to the site.

However, we are aware from previously undertaken work that there were no TPOs or conservation areas affecting the site in 2013.

## 2.6 Tree protection – general advice

It is recommended that the local authority is consulted before any tree works are undertaken, as new TPOs may have been created since the time of enquiry, and heavy fines exist for unauthorised works to protected trees.

A TPO can be overridden by planning consent, where tree removal is necessary to enable the Proposed Development to proceed.

All works to protected trees require consent from the local authority, including pruning. However, this does not include the removal of dead wood, which is exempt. Although dead and

dangerous trees are exceptions to a TPO, it is advisable to give the local authority five days' notice in writing of any intended removal.

In a conservation area, all trees are effectively protected. Where tree work is required in a conservation area, the local authority must be given six weeks' notice of intent, which allows them to either make a TPO or give consent for the intended work. The proposed tree work can proceed after six weeks, if the local authority has not responded.

It is an offence to remove more than 5m<sup>3</sup> of timber in any one calendar quarter without having first obtained a felling licence from the Forestry Commission. It must be noted, however, that this excludes sites where planning permission has already been granted.

## 2.7 Tree works

All specified tree work is to be carried out in accordance with BS 3998:2010 Tree work - Recommendations by a professional and specialist arboricultural contractor, who carries the appropriate experience and insurance cover.

## 2.8 Wildlife

Prior to the commencement of any tree works, the trees should be assessed for the presence of protected species, some of which are subject to the *Wildlife and Countryside Act 1981* (as amended) and the *Conservation of Habitats and Species Regulations 2010*.

Where there is evidence that bats, birds or other protected species are present, the advice of a suitably qualified ecologist should be sought.

If tree works are carried out during the bird nesting season (March to August inclusive), trees would need to be inspected by a qualified ecologist within the 24-hour period prior to the commencement works.

## 3 Arboricultural Impact Assessment (AIA)

### 3.1 Summary of the development

It is proposed to develop 34 plots of residential dwellings on the site and to upgrade the existing access from Preston Road, alongside landscape improvements such as parking and soft landscaping which can be seen on the plans included in Appendix 3.

### 3.2 Tree constraints

BS 5837:2012 recognises that conflicting requirements of the planning system for development means that trees are only one factor which need to be taken into consideration. Although there may be certain specimens that can pose significant constraints to development due to their importance, it is essential that inappropriate tree retention is avoided.

Trees can be adversely affected on development sites if their protection is not factored into the wider project management of onsite operations. We have transposed the tree survey plan over plans detailing current proposals in order to assess the impact on surveyed trees.

### 3.3 Impact of tree loss

As trees are generally confined to the site boundaries, it will be possible to develop the site with a relatively low level of tree loss.

The greatest impact of tree loss would be from G29, a recently planted large, mixed-species group which falls within the footprint of the proposed development.

The Leyland cypress hedgerow H13 will also be lost as a result of the development.

### 3.4 Impact of demolition activities

The existing buildings are to be demolished and although there is sufficient space to carry out the demolition without the need to impact on retained trees, the contractors should refer to the AMS to ensure that disturbance is minimised.

Adequate tree protection measures shall need to be established before demolition takes place and areas should be designated for the storage of debris.

### 3.5 Impact of general construction activity

Tree protection fencing will need to be erected before any construction activity takes place to avoid damage to trees directly by mechanical damage or indirectly due to soil compaction in the Root Protection Areas (RPAs).

It is essential that all site personnel, including temporary contractors, are made aware of the recommendations within this report.

### 3.6 Changes in ground surfaces

A footpath and bike storage are proposed within the RPA of G28. To ensure this work does not have a negative impact on the trees long term health, it must be carried out in strict accordance with the specification provided in the AMS.

## 4 Arboricultural Method Statement (AMS)

### 4.1 Summary of the impacts identified

The following impacts have been identified during the AIA and will be discharged within this AMS:

- Tree loss
- Tree pruning
- Demolition activities
- Installation of utilities
- General construction activity
- Boundary treatments
- Changes in ground surfaces

### 4.2 Development implementation phases

The arboricultural consultant may need to be involved in some or all of the following processes.

Phase of Development	Arboricultural input
<b>Phase 1 - Site preparation</b>	<ul style="list-style-type: none"> <li>• Pre-construction tree surgery works</li> <li>• Demolition of existing structures</li> <li>• Installation of protective fencing</li> <li>• Pre-development inspection</li> </ul>
<b>Phase 2 – Construction process</b>	<ul style="list-style-type: none"> <li>• Installation of services</li> <li>• New surfaces in the RPA</li> </ul>

	<ul style="list-style-type: none"> <li>• Hard landscaping</li> </ul>
<b>Phase 3 – Post-construction</b>	<ul style="list-style-type: none"> <li>• Removal of protective fencing</li> <li>• Soft landscaping</li> <li>• Signing off</li> </ul>

### 4.3 Phase 1 – Site preparation

### 4.4 Tree surgery works

Tree works that are recommended in the Tree Data Schedule in Appendix 1 are of a general maintenance nature and can be carried out at any time as per recommendations.

Tree works required to facilitate the development will be carried out prior to the commencement of any onsite operations. This should allow sufficient space for approved construction to be carried out.

Any unforeseen tree works that become apparent during the construction process will require written consent from the Local Authority Tree Officer.

Any pruning should be carried out under the supervision of the Arboricultural Consultant or the Local Authority Tree Officer to ensure that only branches necessary to facilitate the Proposed Development will be removed and the long-term well-being of retained trees is maintained. All tree surgery work should be carried out in accordance with BS 3998:2010 - Tree work. Recommendations.

## 4.5 General construction activity

All operations that could affect trees on and adjacent to the site must be considered as part of the project management of the Proposed Development. It is therefore imperative that an Arboricultural Consultant is appointed as part of the design and management team to advise on pre-development issues and supervise on-site operations.

The Arboricultural Consultant may also have an advisory role in the preparation of site including tree surgery works and the protection of trees during demolition processes.

The AMS accompanies the AIA and should be read in conjunction with the Tree Protection Plan. It is essential to adhere to the recommendations within this document during on-site operations to ensure the successful retention of trees as part of the Proposed Development. Compliance with the AMS will be a requirement of all relevant contracts associated with the Proposed Development.

The AMS aims to provide general guidelines to onsite personnel that must be followed when working close to trees on construction sites. All site personnel should have access to this document and be made aware of any sections that may be relevant to their specific area of work.

The developer will inform the Local Planning Authority (LPA) within twenty-four hours if the Arboricultural Consultant is replaced.

## 4.6 Potential damage to above ground parts of retained trees

Care will be taken when planning site operations to ensure that wide or tall loads or plant with booms, jibs and counterweights

are able to operate without coming into contact with retained trees. Any contact has the potential to cause life limiting damage. It is therefore essential that any activities in close contact with retained trees is carried out under the supervision of a banksman to maintain sufficient clearances.

Any tree damage must be reported to the Arboricultural Consultant or Local Authority Tree Officer as unreported damage could lead to the structural instability.

## 4.7 Protective fencing

Temporary protective fencing will need to be installed in the positions indicated on the Tree Protection Plan in Appendix 3, prior to the commencement of any construction activities on site including the delivery of materials and site facilities.

Any fencing that is damaged so that it is no longer able to protect retained trees must be replaced/repared immediately with appropriate fencing.

The required specification for protective fencing is illustrated in Figure 3.

The 'in-ground' system involves driving vertical scaffold poles approximately 0.6m into the ground onto which are affixed horizontal scaffold poles and bracing struts. 2m high anti-climb weldmesh panels are then wired to the scaffold framework. The vertical scaffold poles should be at a maximum of 3m apart.

Figure 3. Tree Protection Fencing

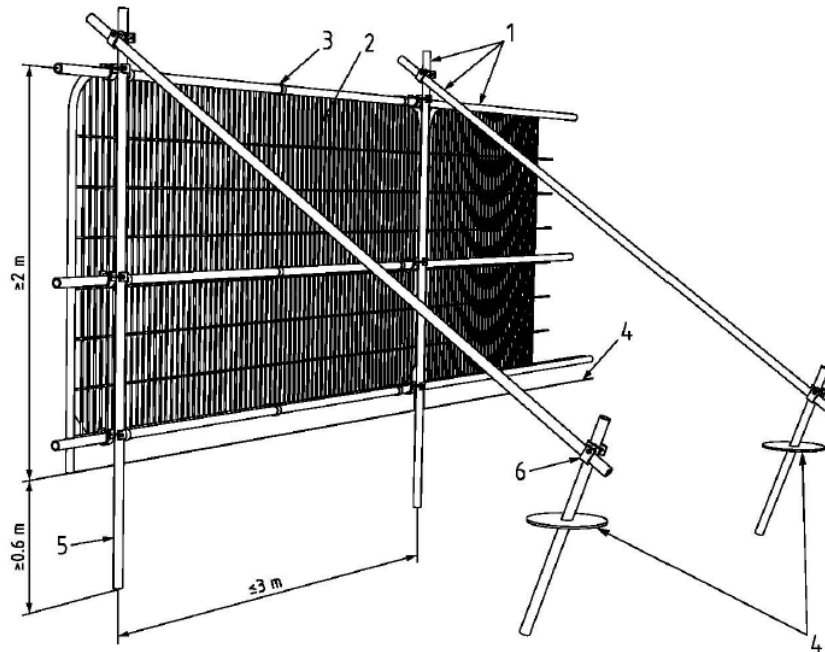

**Key**

- 1 Standard scaffold poles
- 2 Heavy gauge 2 m tall galvanized tube and welded mesh infill panels
- 3 Panels secured to uprights and cross-members with wire ties
- 4 Ground level
- 5 Uprights driven into the ground until secure (minimum depth 0.6 m)
- 6 Standard scaffold clamps

No fixing shall be made to any tree and all possible precautions shall be taken to prevent damage to the tree roots when locating uprights.

A 600mm x 300mm warning sign reading “TREE PROTECTION AREA KEEP OUT” shall be fixed to every 10m of protective fencing. (Fig 4. below).

Figure 4. Tree Protection Notice



### 4.8 Pre-development inspection

The site will be inspected by the appointed Arboricultural Consultant or Local Authority Tree Officer following any facilitative tree surgery works and the installation of protective fencing.

## 4.9 Phase 2 – Construction process

### 4.10 RPAs explained

The RPA is an area of ground around the base of a retained tree, which is calculated in relation to the stem diameter, where disturbance should be kept to a minimum and avoided if at all possible.

The majority of tree roots grow within the upper 600mm of the soil profile where most nutrients are available as the result of the decomposition of organic matter close to the surface. Rooting conditions become less favourable at depth as the soil density increases, creating anaerobic conditions.

It is essential that roots are protected from construction works including physical damage from excavation and changes in soil structure from compaction and changes in ground levels.

### 4.11 Construction Exclusion Zone (CEZ)

No construction activity will take place unless otherwise stated in this report or agreed in writing with the LPA prior to required works. Any required works will be carried out under the supervision of the Arboricultural Consultant or Local Authority Tree Officer

Any materials which have the potential to contaminate the soil, e.g. concrete mixing and diesel oil will not be discharged within 10m of the tree stem. This should take into consideration the topography of the site and slopes, to avoid materials such as concrete washings flowing towards retained trees.

Fires shall not be lit in a position where their flames can extend to within 5m of foliage, branches or trunk. This will depend on the size of the fire and the wind direction.

Notice boards, telephone cables or other services should not be attached to any part of retained trees.

### 4.12 Working in the RPA

The RPA is defined on the Tree Protection Plan Appendix 3 by coral hatched circles surrounding retained trees. Where necessary, temporary protective fencing will be placed in the marked positions, beyond which is a Construction Exclusion Zone (CEZ). This zone precludes all construction activity, with the sole exception of specified arboricultural works that have been agreed by all parties and under the supervision of an arboriculturist.

### 4.13 Demolition in the RPA

During demolition, the following restrictions will apply:

- Where direct damage by falling masonry is likely, the tree should be protected by exterior grade plywood sheets constructed around the main stem.
- The main body of any mechanical excavator will operate outside the RPA.
- Masonry will be pulled away from trees where possible.
- When breaking masonry, a fine water spray will be used to minimise dust particles.
- Excessive dust particles on trees will be removed each day by spraying with water.

Hard surfaces should be kept in place for as long as possible during construction works in order to prevent soil compaction in the RPA.

#### 4.14 Temporary site cabins

All storage facilities and deliveries will make use of existing hard surfaces to avoid unnecessary compaction within RPAs. The locations will be agreed in writing with the LPA prior to delivery and will remain in the agreed locations unless approved by the LPA.

If storage facilities require siting within RPAs, every effort will be made to ensure that any damage to aerial parts of retained trees is avoided and that appropriate footings are used to avoid root damage or compaction of the soil.

#### 4.15 Utilities

Plans detailing to location of services have not been provided as part of this assessment. All services will need to be designed to avoid the RPAs of retained trees including foul and surface water drains, electricity, land drains telephone and cable services, soak-aways, lighting, gas and water.

The installation of underground utilities within the RPA should not be considered unless it is absolutely necessary. Trenching can cause an unacceptable amount of damage to tree roots.

The National Joint Utilities Group publication, NJUG10 recommends the following precautions when working in the RPA:

- No excavation should be carried out using machinery.
- When digging by hand, carefully work around roots, retaining as many as possible.
- Do not sever roots over 25mm in diameter without the consent of the Arboricultural Consultant or Local Authority Tree Officer.

- Any root pruning will be carried out using a sharp tool (eg secateurs or handsaw). Make a clean cut and leave as small a wound as possible.
- Backfill the trench with an inert granular material and topsoil mix. Compact the backfill with care around the retained roots. On non-highway sites backfill only the excavated soil.
- Do not repeatedly move or use heavy mechanical plant except on hard standing.
- Do not store spoil or building material, including chemical and fuels.
- Protect roots with dry sacking if they are to be left exposed overnight when there is a risk of frost. Sacking must be removed before backfilling.

#### 4.16 Excavation in the RPA (applicable to G28)

Any necessary excavation must be carried out using hand tools to avoid direct damage to the protective bark of tree roots. It may be possible in some instances to use specialised equipment such as high air pressure machinery to excavate the soil with minimal disturbance to roots.

Roots less than 25mm diameter may be pruned back, preferably to a growing point. A sharp cutting tool such as bypass secateurs or a handsaw should be used to leave the smallest wound possible. Roots greater than 25mm in diameter should be retained wherever possible.

Root pruning should be carried out under the supervision of the Arboricultural Consultant or the Local Authority Tree Officer to ensure that only roots necessary to facilitate the development will be removed and the long-term well-being of retained trees is maintained.

Backfilling of any excavation should be carried out by hand to avoid direct root damage by excessive compaction and should include, where possible, the replacement of inert granular material mixed with sharp sand (not builder's sand) around retained roots.

#### 4.17 New structures and surface design in the RPA (applicable to G28)

Small, light structures such as bike storage can be laid directly onto the soil surface without the need for significant excavation.

It is essential to maintain adequate supplies of water and oxygen for trees through the soil. New impermeable surfacing should not cover more than 20% of the RPA.

Any pedestrian paving or patios that may be installed over rooting zones, as part of a post construction landscaping scheme, should be constructed in a manner sympathetic to tree roots. Excavation should be limited to 100mm. Paving with a thickness of 50mm bedded on sand with a finished surface which is level with existing ground levels will be acceptable. No retaining kerbs should be used.

Design and construction specification should take account of further growth.

Paving slabs and block pavers are available with built in infiltration spaces between the slabs or blocks. They should be laid dry-jointed on a sharp sand foundation to allow air and moisture to penetrate to the rooting area.

It may be necessary to lay paving and other surfaces on a flexible base to allow movement and to facilitate relaying if distortion becomes excessive due to the activity of tree roots.

Edgings and associated foundations and haunchings can damage tree roots. This should be avoided within the RPA by either the use of alternative methods of edge support or by not using supports at all.

#### 4.18 Changes in ground level

Changes in ground level can be harmful to trees where stripping or filling of soil is carried out in the RPA. It is therefore important that no significant changes in level occur within the RPA of retained trees.

#### 4.19 Boundary treatments

Where fencing is to be installed within RPAs of retained trees, post holes will be excavated by hand and kept as narrow as possible. Trial holes will be dug using a manually operated soil augur in order to position post holes to avoid major roots.

Exploratory post holes will be dug before committing to positions. If any roots in excess of 25mm are encountered they are to remain intact and the post hole will be relocated to avoid them. The fencing system must permit such flexibility (i.e. where fixed panel widths are used, all post holes must be excavated before committing to the final location).

All post holes will be excavated by hand and kept as narrow as possible (maximum diameter 300mm).

Any roots in excess of 10mm which are severed will be neatly pruned back with secateurs. This will encourage healing and reduce the likelihood of infection.

## 4.20 Soft landscaping

No machinery used for landscaping such as rotovators are to operate within the RPAs of retained trees.

All planting must be carried out carefully, by hand to avoid damage to existing roots. Mulch should be used around the base of trees, where possible, to maintain ground level and to avoid mower and strimmer damage to buttresses and surface roots.

## 4.21 Monitoring

The Arboricultural Consultant will be responsible for the monitoring of all arboricultural works and issuing a certificate of practical completion.

A record of site visits will be maintained for inspection on site and copies forwarded to the developer/agent and to the LPA.

## 4.22 Phase 3 – Post development

### 4.23 Removal of protective fencing and signing off

When the construction process is complete, the site should be inspected by the appointed arboriculturist or Local Authority Tree Officer. This must be prior to the removal of temporary protective fencing.



Any proposed landscaping operations by heavy machinery should be carried out before the protective fencing is removed.

## Appendix 1 - Tree Data Schedule

- The following pages contain information gathered during the site survey.
- The reader should refer to Appendix 2 in order to correctly interpret the tree data.
- All images within the Tree Data Schedule are diagrammatical only. Their purpose is to indicate, at a glance, the relative dimensions of each tree. The images are computer generated based on measurements recorded for stem diameter, crown spread, crown height and overall height.

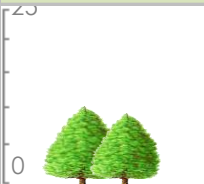
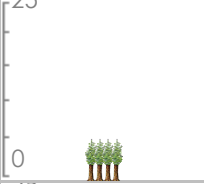
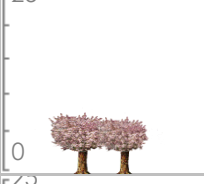
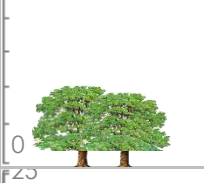
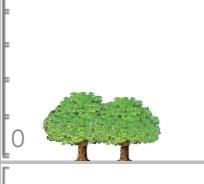
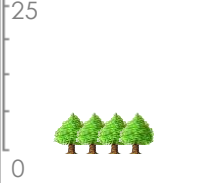
Reference G = Group H = Hedge	Age & Species	Height (m)	Crown Ht (m)	Diameter (mm)	Crown Spread (m)			Scaled Tree Diagram (m)	Notes	Recommendations		Physiological Condition	Life Expectancy (yrs)
					W	N	E			Priority	Inspect Freq (yrs)	Structural Condition	Retention Category
T1	Semi-Mature <b>Hornbeam</b>  Carpinus betulus	7.5	2	360	4.5	4	3.5		2: Multi-stemmed at 2.5m with a full crown. 3: Occasional pruning wounds due to crown lifting. 4: Crossing branches to lower crown. 5: Acceptable condition at present.	No action required.	Good	40+	
	4.5						n/a			3			Fair
T2	Semi-Mature <b>Maple</b>  Acer sp	8	3	310	5.5	4	3.5		2: Multi-stemmed at 2.5m with a balanced crown. 3: Occasional pruning wounds due to crown lifting. 4: Minor deadwood throughout crown. 5: Acceptable condition at present.	No action required.	Good	40+	
	4						n/a			3			Good
T3	Semi-Mature <b>Beech</b>  Fagus sylvatica	8.5	3	250	3.5	3	3		2: Single stemmed with a slight lean and a full crown. 3: No evidence of significant pruning. 4: No significant defects.	No action required.	Good	40+	
	4						n/a			3			Good
T4	Semi-Mature <b>London Plane</b>  Platanus x hispanica	10	3.5	220	3.5	3	3.5		2: Multi-stemmed at 2.5m with an unbalanced crown. 3: No evidence of significant pruning. 4: No significant defects.	No action required.	Good	40+	
	4.5						n/a			3			Good
T5	Young <b>Ash</b>  Fraxinus excelsior	6	3	180	2.5	2.5	2.5		2: Twin-stemmed at 2.5m with a balanced crown. 3: No evidence of significant pruning. 4: No significant defects.	No action required.	Good	40+	
	3						n/a			3			Good
H6	Semi-Mature <b>Leyland Cypress</b>  x Cupressocyparis leylandii	av 3.5	0	100	0.3	0.3	0.3		2: Formally maintained hedge. 3: Regularly trimmed. 4: No significant defects.	No action required.	Good	40+	
							n/a			3			Good

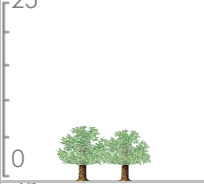
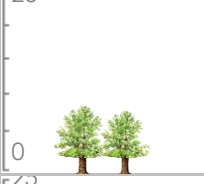
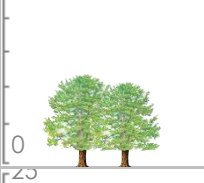
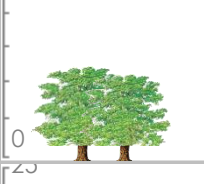
Reference G = Group H = Hedge	Age & Species	Height (m)	Crown Ht (m)	Diameter (mm)	Crown Spread (m) N W E S	Scaled Tree Diagram (m)	Notes	Recommendations		Physiological Condition	Life Expectancy (yrs)
								Priority	Inspect Freq (yrs)	Structural Condition	Retention Category
G7	Semi-Mature <b>Lawson Cypress</b> <i>Chamaecyparis lawsoniana</i>	av 10	0	av 150	av 3 3 3 each		2: Small group. 3: No evidence of significant pruning. 4: No significant defects.	No action required.	3	Good	40+
								n/a		Good	C
H8	Semi-Mature <b>Hawthorn</b> <i>Crataegus monogyna</i>	av 4.5	2	60	0.5 0.5 0.5		2: Lapsed hedgerow. 3: Scatterd cherry & oak within hedge. 4: No significant defects.	No action required.	3	Good	40+
								n/a		Good	B
G9	Semi-Mature <b>Wild Cherry</b> <i>Prunus avium</i>	av 7.5	av 3	av 250	av 3.5 3.5 3.5 each		2: Linear boundary group in hedgerow. 3: No evidence of significant pruning. 4: No significant defects.	No action required.	3	Good	40+
								n/a		Good	C
G11	Semi-Mature <b>Sycamore</b> <i>Acer pseudoplatanus</i>	av 9.5	av 2	av 250	av 3.5 3.5 3.5 each		2: Single stemmed and vertical with an unbalanced crown. 3: No evidence of significant pruning. 4: No significant defects.	No action required.	3	Good	40+
								n/a		Good	B-
G12	Semi-Mature <b>Horse Chestnut</b> <i>Aesculus hippocastanum</i>	av 8.5	av 2	av 250	av 3 3 3 each		2: Informal group within mixed species group. 3: No evidence of significant pruning. 4: No significant defects.	No action required.	3	Good	40+
								n/a		Good	B
H13	Semi-Mature <b>Leyland Cypress</b> <i>x Cupressocyparis leylandii</i>	av 4	0	150	av 1 1 1 each		2: Formally maintained hedge. 3: Regularly trimmed. 4: No significant defects.	No action required.	3	Good	40+
								n/a		Good	C

Reference G = Group H = Hedge	Age & Species	Height (m)	Crown Ht (m)	Diameter (mm)	Crown Spread (m) N W E S	Scaled Tree Diagram (m)	Notes	Recommendations		Physiological Condition	Life Expectancy (yrs)
								Priority	Inspect Freq (yrs)	Structural Condition	Retention Category
G14	Semi-Mature <b>Larch</b>  Larix decidua	av 10.5	av 1	av 250	2  2  each		2: Informal group within mixed species group. 3: No evidence of significant pruning. 4: No significant defects.	No action required.	Good	40+	
								n/a	3	Good	C+
G15	Semi-Mature <b>Rowan</b>  Sorbus aucuparia	av 6	av 1.5	av 200	2.5  2.5  each		2: Informal group within mixed species group. 3: No evidence of significant pruning. 4: No significant defects.	No action required.	Good	40+	
								n/a	3	Good	C+
G16	Semi-Mature <b>Alder (common)</b>  Alnus glutinosa	av 8.5	av 2	av 200	2.5  2.5  each		2: Informal group within mixed species group. 3: No evidence of significant pruning. 4: No significant defects.	No action required.	Good	40+	
								n/a	3	Good	C+
G17	Semi-Mature <b>Beech</b>  Fagus sylvatica	av 12	av 2	av 200	3  3  each		2: Informal group within mixed species group. 3: No evidence of significant pruning. 4: No significant defects.	No action required.	Good	40+	
								n/a	3	Good	C+
G18	Semi-Mature <b>Ash</b>  Fraxinus excelsior	av 12.5	av 2	av 300	4  4  each		2: Informal group within mixed species group. 3: No evidence of significant pruning. 4: No significant defects.	No action required.	Good	40+	
								n/a	3	Good	B
G19	Semi-Mature <b>Sessile Oak</b>  Quercus petraea	av 8.5	av 1.5	av 200	3.5  3.5  each		2: Informal group within mixed species group. 3: No evidence of significant pruning. 4: No significant defects.	No action required.	Good	40+	
								n/a	3	Good	B

Reference G = Group H = Hedge	Age & Species	Height (m)	Crown Ht (m)	Diameter (mm)	Crown Spread (m)			Scaled Tree Diagram (m)	Notes	Recommendations		Physiological Condition	Life Expectancy (yrs)
					W	N	E			Priority	Inspect Freq (yrs)	Structural Condition	Retention Category
<b>H20</b>	Semi-Mature <b>Hawthorn</b> <i>Crataegus monogyna</i>	av 1	2	50	5	5	5		2: Hedge. 3: Regularly trimmed. 4: No significant defects.	No action required.	3	Good	40+
										n/a		Good	<b>B</b>
<b>T21</b>	Early-Mature <b>Elm</b> <i>Ulmus sp</i>	9	2	380	4	4	4.5		2: Twin-stemmed at ground level with a full crown. 3: Occasional pruning wounds due to crown lifting. 4: No significant defects.	No action required.	3	Good	40+
										n/a		Good	<b>B</b>
<b>G22</b>	Semi-Mature <b>Elm</b> <i>Ulmus sp</i>	av 8.5	av 1.5	av 200	2.5	2.5	2.5		2: Boundary group within hedgerow. 3: No evidence of significant pruning. 4: No significant defects.	No action required.	3	Good	40+
										n/a		Good	<b>C+</b>
<b>T23</b>	Semi-Mature <b>Ash</b> <i>Fraxinus excelsior</i>	8.5	2	180	3	3.5	2		2: Twin-stemmed at 0.5m with a slightly unbalanced crown. 3: Occasional pruning wounds due to crown lifting. 4: No significant defects.	No action required.	3	Good	40+
										n/a		Good	<b>C</b>
<b>G24</b>	Semi-Mature <b>Elm</b> <i>Ulmus sp</i>	av 5.5	av 2	av 150	2.5	2.5	2.5		2: Boundary group within hedgerow. 3: No evidence of significant pruning. 4: No significant defects.	No action required.	3	Good	40+
										n/a		Good	<b>C</b>
<b>T25</b>	Semi-Mature <b>Elm</b> <i>Ulmus sp</i>	11. 5	2	310	3	5.5	4		2: Twin-stemmed at ground level with a full crown. 3: No evidence of significant pruning. 4: No significant defects.	No action required.	3	Good	40+
										n/a		Good	<b>B-</b>

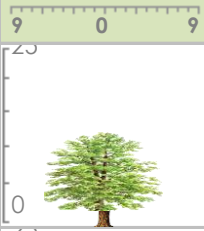
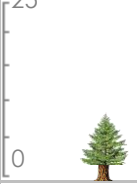
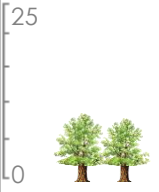
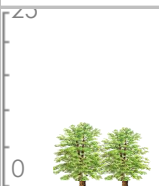
Reference G = Group H = Hedge	Age & Species	Height (m)	Crown Ht (m)	Diameter (mm)	Crown Spread (m)			Scaled Tree Diagram (m)	Notes	Recommendations		Physiological Condition	Life Expectancy (yrs)
					W	N	E			Priority	Inspect Freq (yrs)	Structural Condition	Retention Category
<b>T26</b>	Semi-Mature <b>Elm</b>  Ulmus sp	12	2	340	5	5	3.5		2: Twin-stemmed at 3m with a full crown. 3: Occasional pruning wounds due to crown lifting. 4: No significant defects.	No action required.	Good	40+	
	5						n/a			3			<b>B</b>
<b>T27</b>	Semi-Mature <b>Pine</b>  Pinus sp	8	2	330	1.5	1	2		2: Single stemmed and vertical with a slightly unbalanced crown. 3: Situated on north boundary. 4: No significant defects observed. 5: Possible nesting birds present.	No action required.	Good	40+	
	2.5						n/a			3			<b>C+</b>
<b>G28</b>	Semi-Mature <b>Mixed</b>  Species	av 8.5	av 2	av 250	av 2.5	av 2.5	av 2.5		2: Mixed group consisting of ash, cherry, larch, sycamore, oak and alder. 3: Minor deadwood throughout crown. 4: Not plotted on topo. 5: Acceptable condition at present.	No action required.	Good	40+	
				each			n/a			3			<b>B</b>
<b>G29</b>	Young <b>Mixed</b>  Species	av 8	av 1	av 150	av 2	av 2	av 2		2: Mixed group consisting of spruce, pine and rowan. 3: Recently planted. 4: No significant defects.	No action required.	Good	40+	
				each			n/a			3			<b>C</b>

## Appendix 2 – Tree Schedule Definition of Terms

Tree Referencing	<b>Individual Trees</b> T (+number) <b>Grouped Trees</b> G (+number) <b>Hedgerows</b> H (+number) <b>Woodlands</b> W(+number)
Age Category	<b>Young</b> Usually <15 years <b>Semi-mature</b> Significant growth expected, approximately one third of life expectancy complete <b>Early-Mature</b> Full height achieved with further significant growth possible, up to two thirds of life expectancy complete <b>Mature</b> Full height has been achieved with possible spreading of the canopy, usually past two thirds of overall life expectancy <b>Veteran</b> Usually a tree of significant age with characteristics that give additional cultural, landscape and conservation benefits, <b>Over-mature</b> A tree declining due to age as indicated by deterioration in the health and condition of its crown and trunk.
Species	<b>Botanical Name</b> - conforming to the International Code of Nomenclature for algae, fungi, and plants (ICN). For universal plant recognition. <b>Common Name</b> – commonly used names usually on a local and national scale.
Tree Height	The vertical distance between the base of the tree (where soil and buttress meet) and the tip of the highest branch on the tree.
Crown Height	Measured from ground level to the height at which the main crown begins.
Stem Diameter (DBH)	Stem diameter is measured at 1.5 m above ground level
Tree Diagrams	A diagrammatical representation of the tree taken from measurements of stem diameter, crown height and spread, and overall height.
Crown Spread: Crown	Measurements taken from all four cardinal points in metres.
Notes	Notes are made to inform of any possible defects, peculiarities or points of interest that may relate to the trees position, physiology, safety and possible effects on developments.
Recommendations	Recommendations are made in accordance to good arboricultural practice. Recommendations are made regardless to the end usage of the site.
Priority Scale	Priority is given dependant on the perceived threat and the likelihood of failure given to a possible hazard. The priority of work is given regardless of the end usage of the site. <b>Urgent</b> To be carried out as soon as possible. <b>Very High</b> To be carried out within 1 month. <b>High</b> To be carried out within 3 months. <b>Moderate</b> To be carried out within 1 year. <b>Low</b> To be carried out within 3 years.
Physiological Condition:	<b>Good</b> Usually healthy with no symptoms of poor health or disease. <b>Fair</b> Exhibiting signs of poor health or minor disease infections that are not considered to be hazardous. <b>Poor</b> Disease present in considerable quantities or with very poor physiological vigour. <b>Very Poor</b> Tree is in a moribund state in extremely poor condition, usually with little chance of recovery.
Structural Condition:	<b>Good</b> A tree with no significant structural defects. <b>Fair</b> Minor defects may have been observed but are not considered to be immediately hazardous. <b>Poor</b> Significant defects found. Tree requires monitoring or remedial works. <b>Very Poor</b> Major defects that require immediate remedial work or the removal of the tree.
Life Expectancy:	The estimated number of years before the tree may require removal should no unexpected mechanical or environmental impacts occur to the tree.
Retention Category:	Please refer to Tree retention categorisation table on the next page.

**Tree Retention Category** – The following table provides an explanation of retention categories used.

Trees to be removed		Colour on Plan
Category U includes trees of very low quality that offer little or no amenity value.	Trees that are in such a condition that they should be removed as a matter of good arboricultural practice regardless of given proposals.	RED
Trees to be considered for retention		Colour on Plan
Category A Trees of a high quality, with an estimated life of expectancy of at least 40 years	Trees that are excellent examples of their species, usually mature, with a safe useful life expectancy of at least 40 years. Category A trees are likely to enhance a development and should be retained wherever possible.	GREEN
Category B includes trees of moderate quality and amenity value.	Trees that are good examples of their species but may have defects or form that downgrade them from category A. Category B trees are usually mature or younger trees with the potential to reach A category in the future. Although the retention of these trees is desirable, some losses may be acceptable.	BLUE
Category C includes trees of low quality and amenity value.	Trees that are either young with a stem diameter less than 150mm or are unlikely to make a contribution for more than 10 years. The removal of these trees should be seen as acceptable in order to allow development to proceed. It may be possible to transplant younger specimens.	GREY
NOTE: Trees that are viewed as borderline and do not fit neatly into either of the categories are given a plus or minus rating (+/-) in the tree data schedule. Therefore C+ would denote a tree being borderline C/B although C is deemed to be the most appropriate category. Similarly B- would denote a tree being borderline B/C with B seen as the most appropriate category.		

## Appendix 3 – Site Plans

The site plans referred to in the report follow this page which include the following:

- Tree Constraints Plan
- Arboricultural Impact Assessment
- Tree Removal Plan
- Tree Protection Plan







Although included plans are usually to scale, they are only intended to indicate positions of surveyed trees and dimensions should not be taken from these drawings.

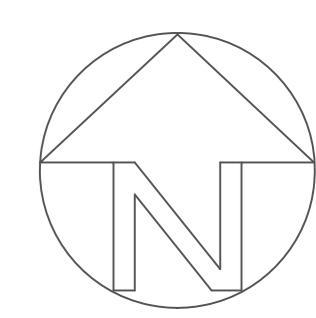

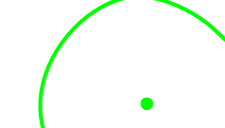
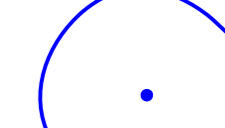
Do not scale this drawing (printed or electronic version).  
 Contractors must check all dimensions from site.  
 This drawing is copyright and is for use on this site only. This drawing should be read in conjunction with all relevant consultants drawings and specialist subcontractors / supply chain drawings and specifications.  
 All works to be carried out in accordance with the latest British Standards / Codes of Practice unless specifically directed otherwise in the specification.  
 Responsibility for the reproduction of this drawing in paper form, or issued in electronic format, lies with the recipient to check that all information has been replicated in full and is correct when compared to the original paper or electronic image.  
 Graphical representations of equipment on this drawing have been co-ordinated, but are approximations only. Please refer to the specifications and / or details for actual sizes and / or specific contractor construction information.

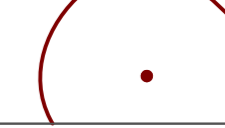
Notes:-

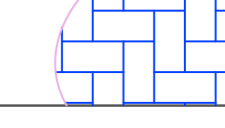

-  Category A tree, group or hedge
-  Category B tree, group or hedge
-  Category C tree, group or hedge
-  Category U tree, group or hedge
-  Root Protection Area (RPA)
-  RPA affected by surface changes
-  RPA affected by foundations
-  RPA affected by boundary treatments

P02	14/06/16	Drawing amendments	DL	NS
P01	08/06/16	Planning	DL	NS
REV.	DATE	DESCRIPTION	DRAWN	CHKD



21 Swan Street Manchester M4 5JJ  
 T: 0161 312 3131 W: urbangreen-space.co.uk

Client:  
 Mr Denis Lambert

Project:  
 Spout Farm, Longridge

Title:  
 Arboricultural Impact Assessment

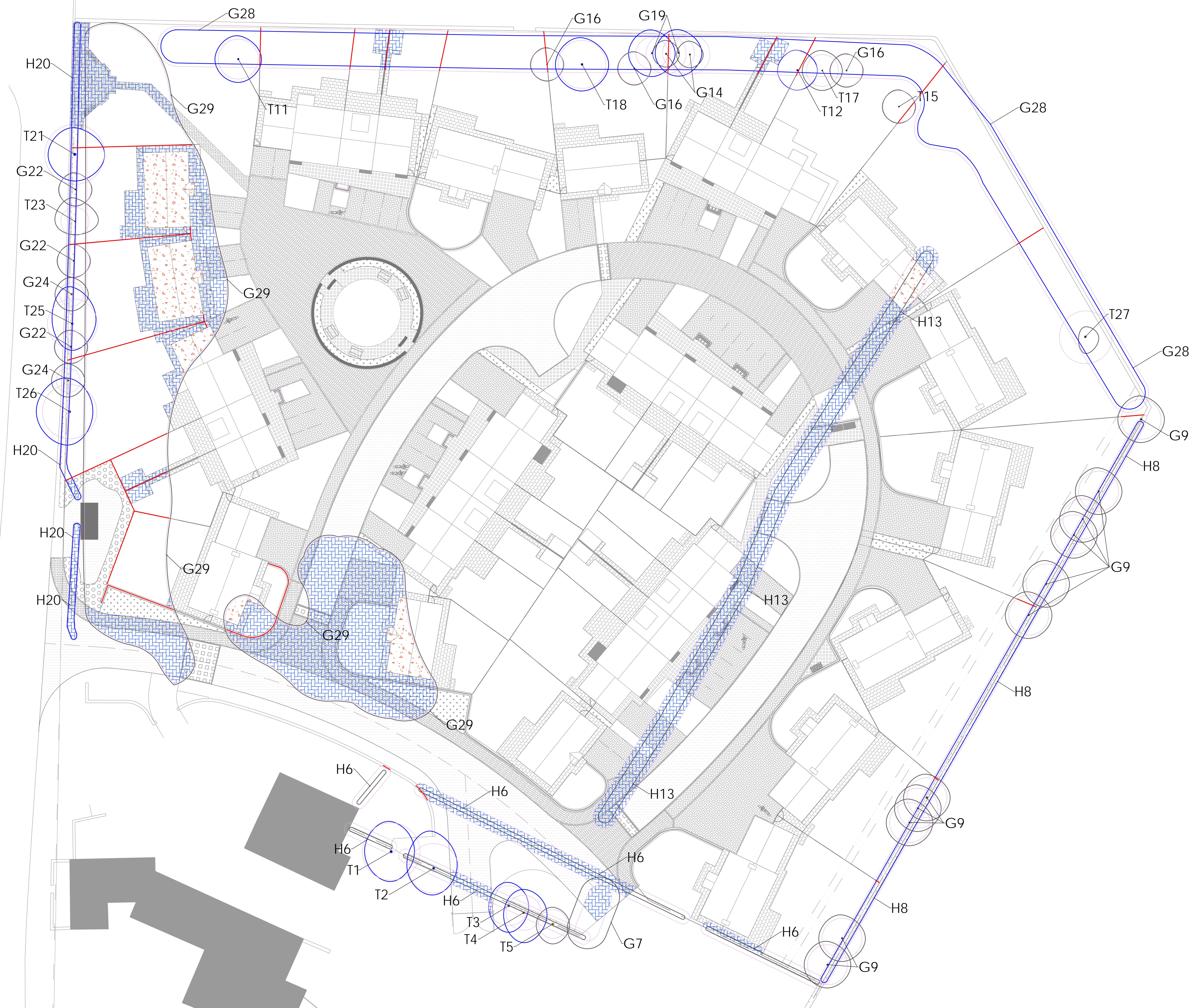

Status:	Planning				
Project:	10399	Drawn:	DL	Checked:	NS
Scale @ A0:	1:200	Date:	14/06/16	Approved:	JC
Drawing No:	10399.T02	Revision:	P02		

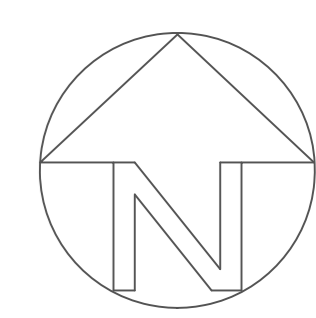

Do not scale this drawing (printed or electronic version).  
 Contractors must check all dimensions from site.  
 This drawing is copyright and is for use on this site only. This drawing should be read in conjunction with all relevant consultants drawings and specialist subcontractors / supply chain drawings and specifications.  
 All works to be carried out in accordance with the latest British Standards / Codes of Practice unless specifically directed otherwise in the specification.  
 Responsibility for the reproduction of this drawing in paper form, or issued in electronic format, lies with the recipient to check that all information has been replicated in full and is correct when compared to the original paper or electronic image.  
 Graphical representations of equipment on this drawing have been co-ordinated, but are approximations only. Please refer to the specifications and / or details for actual sizes and / or specific contractor construction information.

Notes:-

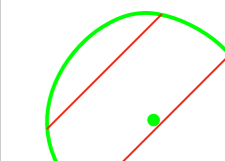
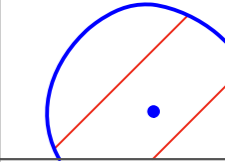
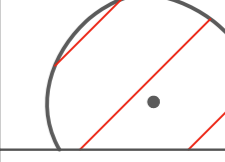
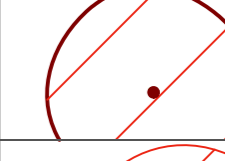

-  Category A tree, group or hedge
-  Category B tree, group or hedge
-  Category C tree, group or hedge
-  Category U tree, group or hedge
-  Extents of pruning

P02	14/06/16	Drawing amendments	DL	NS
P01	08/06/16	Planning	DL	NS
REV.	DATE	DESCRIPTION	DRAWN	CHKD



21 Swan Street Manchester M4 5JJ  
 T: 0161 312 3131 W: urbangreen-space.co.uk

Client: Mr Denis Lambert

Project: Spout Farm, Longridge

Title: Tree Removal Plan

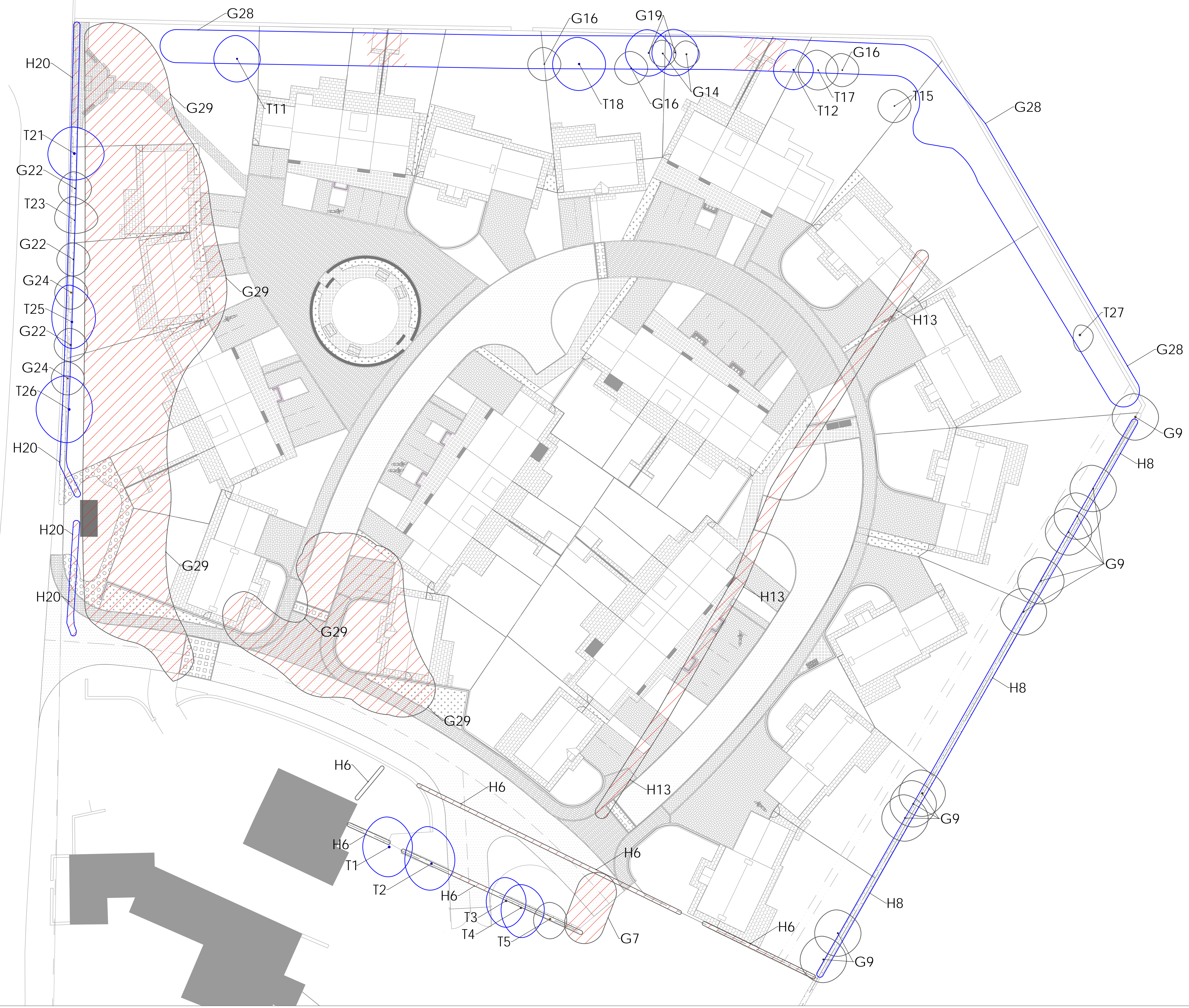

Status:	Planning				
Project:	10399	Drawn:	DL	Checked:	NS
Scale @ A0:	1:200	Date:	14/06/16	Approved:	JC
Drawing No:	10399.T03	Revision:	P02		

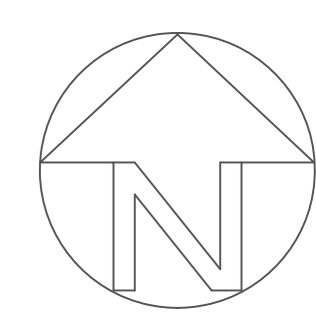

Do not scale this drawing (printed or electronic version).  
 Contractors must check all dimensions from site.  
 This drawing is copyright and is for use on this site only. This drawing should be read in conjunction with all relevant consultants drawings and specialist subcontractors / supply chain drawings and specifications.  
 All works to be carried out in accordance with the latest British Standards / Codes of Practice unless specifically directed otherwise in the specification.  
 Responsibility for the reproduction of this drawing in paper form, or issued in electronic format, lies with the recipient to check that all information has been replicated in full and is correct when compared to the original paper or electronic image.  
 Graphical representations of equipment on this drawing have been co-ordinated, but are approximations only. Please refer to the specifications and / or details for actual sizes and / or specific contractor construction information.

Notes:-

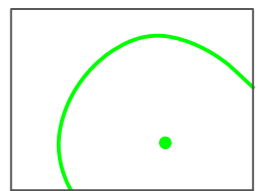
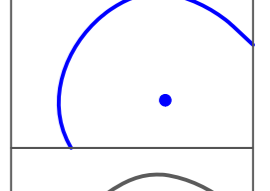
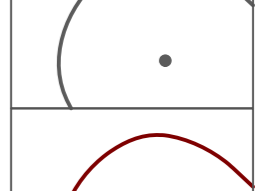
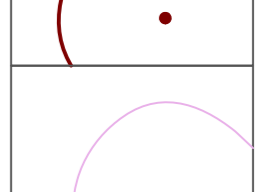
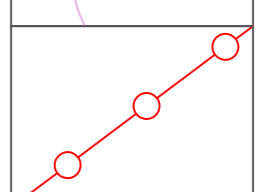
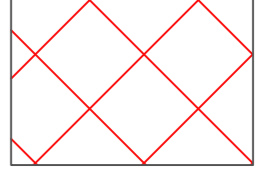

-  Category A tree, group or hedge
-  Category B tree, group or hedge
-  Category C tree, group or hedge
-  Category U tree, group or hedge
-  Root Protection Area (RPA)
-  Protective fencing
-  RPA not protected by fencing (special care required)

P02	14/06/16	Drawing amendments	DL	NS
P01	08/06/16	Planning	DL	NS
REV.	DATE	DESCRIPTION	DRAWN	CHK'D



21 Swan Street Manchester M4 5JJ  
 T: 0161 312 3131 W: urbangreen-space.co.uk

Client: Mr Denis Lambert

Project: Spout Farm, Longridge

Title: Tree Protection Plan

Status:	Planning				
Project:	10399	Drawn:	DL	Checked:	NS
Scale @ A0:	1:200	Date:	14/06/16	Approved:	JC
Drawing No:	10399.T04		Revision:	P02	

