

Existing Ground Floor Plan - 1:100

Existing First Floor Plan - 1:100

Existing Second Floor Plan - 1:100



Proposed South East Elevation - As Application Ref: 3/2015/0841 - Replacement Window and Door Works, granted permission 15.04.2016, subject to Discharge of Conditions 4 and 7. 1:100

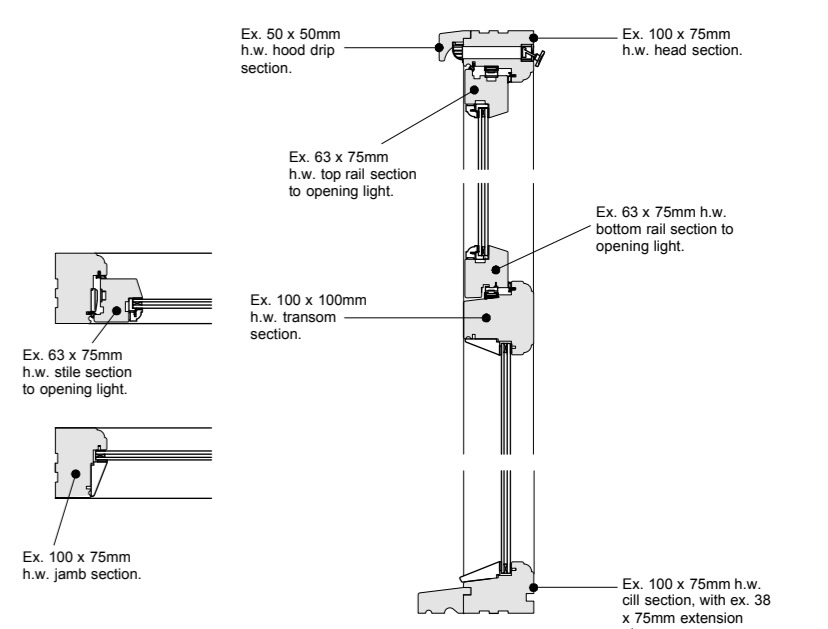

Typical Replacement Casement Window Details to Rear Elevation
 Scale 1:10 @ A1



Existing South East Elevation - 1:100



Existing North West Elevation - 1:100



Proposed South East Elevation - Proposed Replacement of Windows WS.2 and WS.3, as Details Below. 1:100



Proposed North West Elevation - Proposed Replacement of Windows to Rear Elevation, as Details Below. 1:100

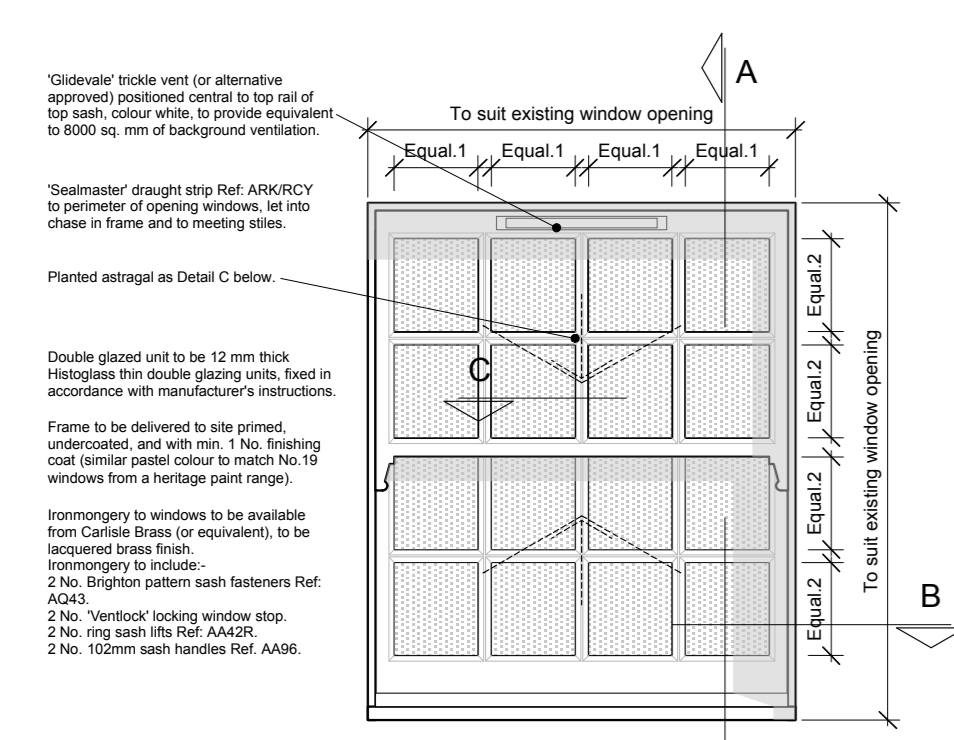

Typical Elevation to Proposed New Sash Windows
 Scale 1:20 @ A1

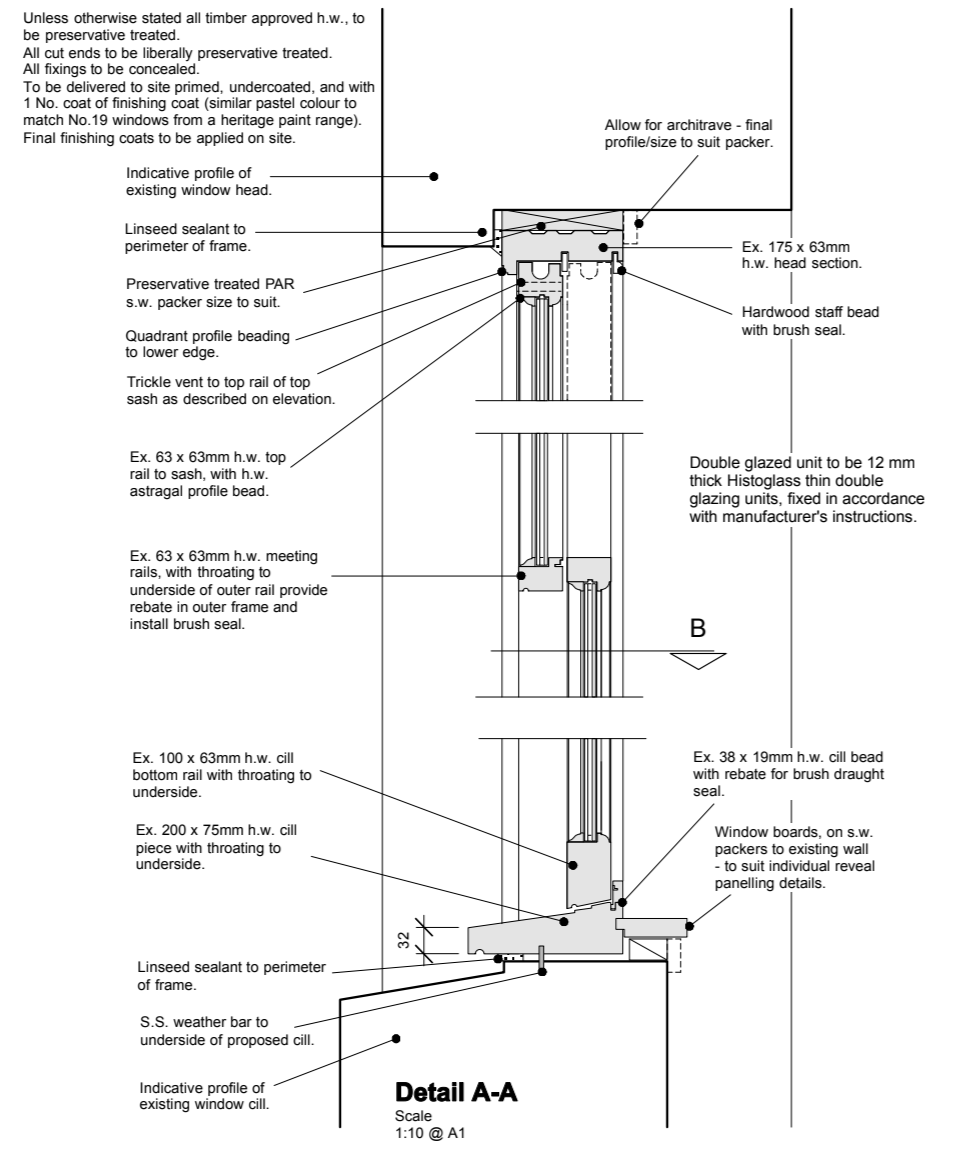

Detail A-A
 Scale 1:10 @ A1

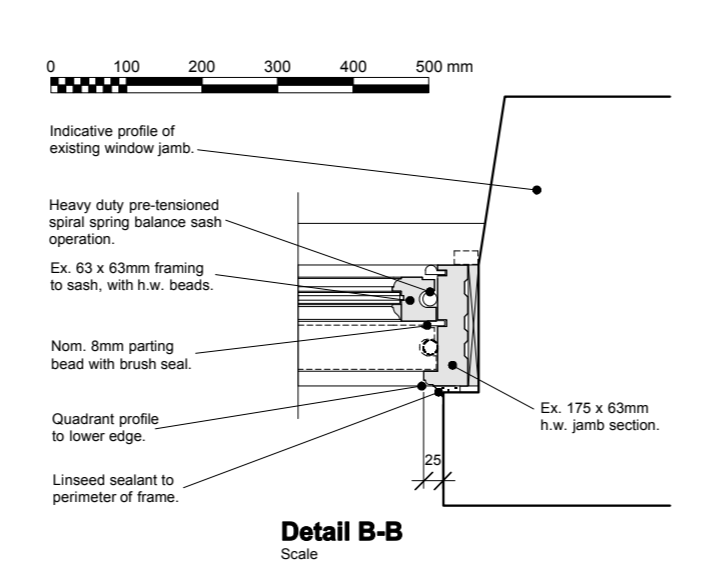

Detail B-B
 Scale 1:10 @ A1

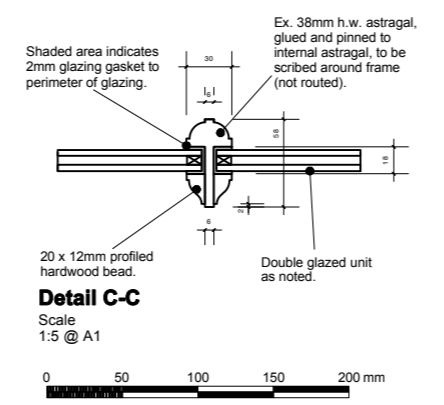

Detail C-C
 Scale 1:5 @ A1

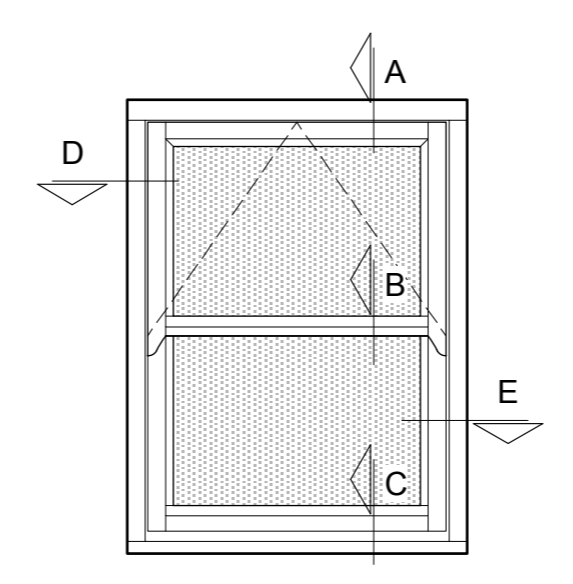

Typical Elevation to Proposed Mock Sash Casement Windows to Rear Elevation.
 Scale 1:20 @ A1

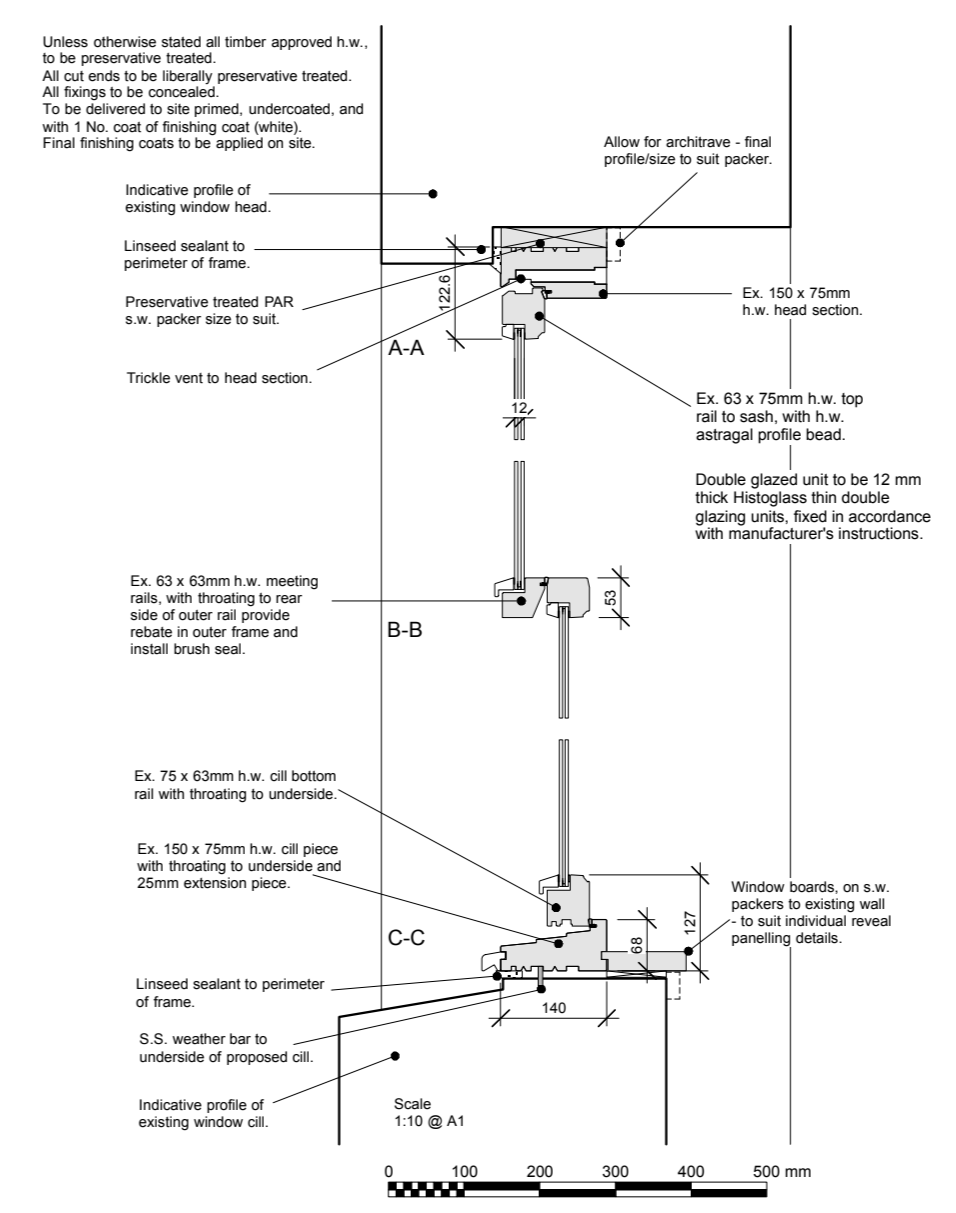

Scale 1:20 @ A1

Scale 1:10 @ A1

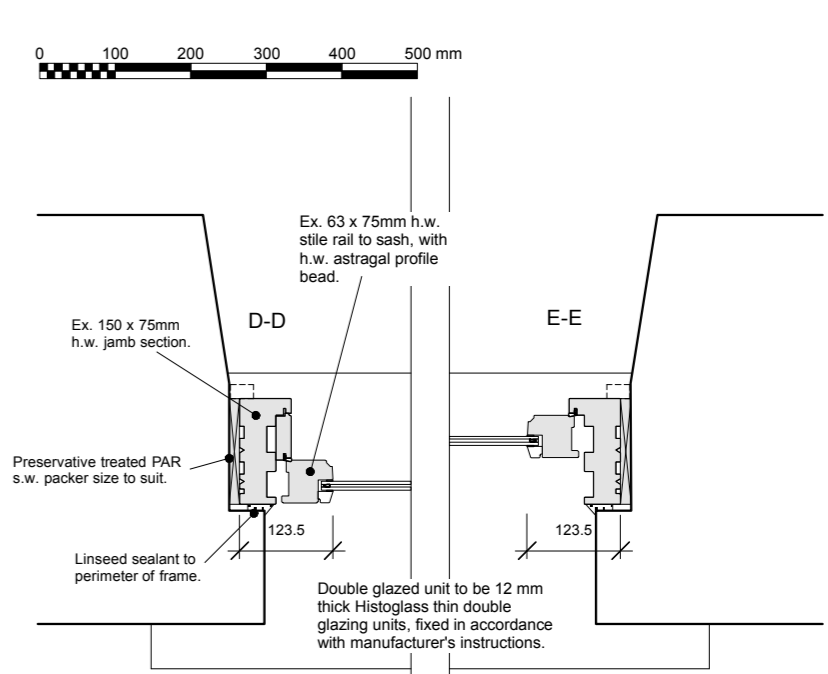

Scale 1:10 @ A1

Rev.	Date	Description

15-17 York Street Clitheroe

Existing and Proposed Elevations - Window and Door Replacement

Drwg. No.: 2314.P.05	Rev.: -
Date: Oct '16	Scale: 1:100, 1:20, 1:10 and 1:5@A1

IWA Architects

Waterloo Mill, Waterloo Road, Clitheroe, Lancashire, BB7 1LR.
 t: +44 (0) 1200 423487
 f: +44 (0) 1200 458278
 e: admin@iwaarchitects.co.uk
 w: www.iwaarchitects.co.uk