

320161061P

# soiltechnics

environmental and geotechnical consultants

Proposed residential development  
Land east of Chipping Lane  
Longridge, Preston

Ground Investigation Report  
(Phase 1)

Ivy Mill Business Centre, Crown Street, Failsworth, Manchester M35 9BG

t: 0161 9470270

e: [mail@soiltechnics.net](mailto:mail@soiltechnics.net)

w: [www.soiltechnics.net](http://www.soiltechnics.net)

**Proposed residential development  
Phase 1  
Land East of Chipping Lane  
Longridge  
Preston  
PR3 2NA**

**GROUND INVESTIGATION REPORT**

Soiltechnics Ltd. Ivy Mill Business Centre, Crown Street, Failsworth, Manchester, M35 9BG  
Tel: (0161) 9470270 E-mail: [mail@soiltechnics.net](mailto:mail@soiltechnics.net)

**Report originators**

Prepared  
by



T. Linden Richardson  
B.Eng. (Hons), MSc., AIEMA

[linden.richardson@soiltechnics.net](mailto:linden.richardson@soiltechnics.net)  
Geo-environmental Engineer, Soiltechnics Limited

Supervised/  
Reviewed  
by

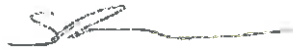

Sam Dean B.Sc. (Hons), FGS., MIEnvSc.

[sam.dean@soiltechnics.net](mailto:sam.dean@soiltechnics.net)  
Associate Director, Soiltechnics Limited

Reviewed  
by



David Dunkley B.Sc. (Hons), CEnv., FGS

[david.dunkley@soiltechnics.net](mailto:david.dunkley@soiltechnics.net)  
Director, Soiltechnics Limited



## Aerial photograph of site



Approximate Phase 1 site boundaries edged in pink

## Report status and format

Report section	Principal coverage	Report status	
		Revision	Comments
1	Executive summary		
2	Introduction		
3	Desk study information and site observations		
4	Fieldwork		
5	Ground conditions encountered		
6	Laboratory testing		
7	Engineering assessment		
8	Chemical contamination		
9	Gaseous contamination		
10	Effects of ground conditions on building materials		
11	Landfill Issues		
12	Further investigations		
13	Remediation statement		
14	Drawings		

## List of drawings

Drawing	Principal coverage	Status	
		Revision	Comments
01	Site location plan		
02a	Plan showing existing site features and location and extent of development phases		
02b	Plan showing existing site features and location of exploratory points		
03	Plan showing site development proposals and location of exploratory points		
04	Plot summarising results of hand held shear vane and pocket penetrometer determinations		
05	Plot summarising results of Dynamic Cone Penetration (DCP) testing		
06	Section showing construction of standpipes installed in boreholes DTS02, DTS03, DTS05 and DTS06		
07	Plan showing site development proposals, location of exploratory points and areas where foundations may require deepening		

## List of appendices

<b>Appendix</b>	<b>Content</b>
<b>A</b>	<b>Definitions of geotechnical terms used in this report</b>
<b>B</b>	<b>Definitions of geo-environmental terms used in this report</b>
<b>C</b>	<b>Trial pit records</b>
<b>D</b>	<b>Borehole records (driven tube sampler)</b>
<b>E</b>	<b>Infiltration test records</b>
<b>F</b>	<b>Copies of laboratory test result certificates – classification testing</b>
<b>G</b>	<b>Copies of laboratory test result certificates – concentrations of chemical contaminants</b>
<b>H</b>	<b>Analysis and summary of test data in relation to concentrations of chemical contaminants</b>
<b>I</b>	<b>Conceptual models for chemical contamination</b>
<b>J</b>	<b>Copies of Statutory Undertakers replies</b>
<b>K</b>	<b>Copy of correspondence received from the Local Authority Environmental Health Officer</b>
<b>L</b>	<b>Copy of Phase 1 Desk Study report undertaken by Curtins Consulting Ltd</b>

# 1 Executive summary

## General

We recommend the following executive summary is not read in isolation to the main report which follows.

## Site description, history and development proposals

The site, approximately 5.4Ha in size, comprised three open grassed fields separated by mature hedgerows and sporadic trees, positioned on the north-western outskirts of Longridge, Preston. It is understood that the land is currently used by livestock for grazing. Localised ponding of surface water was evident across the site. Higgin Brook is also recorded onsite.

Historically the site has remained undeveloped farm land. We understand the scheme in its entirety will comprise the construction of up to 363 dwellings within what is termed Phases 1 and 2 (refer to Drawing O2a for details), with associated landscaping, gardens, hardstanding and access roads. This report refers to the Phase 1 area only in which 118 dwellings are proposed.

## Ground conditions encountered

Near surface soils comprised Topsoil (to depths of between 0.2m and 0.6m) overlaying cohesive Devensian Till deposits to beyond depths of investigation (>4.7m). Till comprised low to very high strength brown mottled grey and orange brown/grey, slightly silty to silty, slightly sandy, slightly gravelly clay in the initial 1m-1.5m below surface level. Below such depths deposits generally exhibit an increase in shear strength and trend towards a brown mottled grey, dark brown and reddish brown colour with varying amounts of silt, sand and gravel. Locally, shear strengths were noted to reduce in value below depths of 2.5m-3.0m. Furthermore, suspected reworked Devensian Till deposits were noted in borehole DTS01 to a depth of 2.1m, which exhibited lower than average shear strengths in comparison to surrounding soils (possibly associated with a former track).

## Foundation solution

Traditional strip/trench fill type foundations considered suitable for the site, located at a minimum depth of 0.9m. Foundations will require deepening locally due to the presence of reworked and low strength soils. CBR value of 2.17% considered representative of near surface soils. Buried concrete at the site would be classified as DS-1 AC-1s based on sulphate levels in Devensian Till. Infiltration testing indicates that the near surface Devensian Till deposits are impermeable. Severe instability in foundation/service trenches is unlikely. No groundwater recorded at the site. Refer to Section 7 for further details and recommendations on additional investigations.

## Chemical and gaseous contamination

We have not identified any significant chemical or gaseous contamination at the subject site, therefore, remediation is not considered necessary. We recommend that hardness values within surface waters of Higgin Brook are determined to enable a more detailed risk assessment to be completed in relation to water receptors. It is unlikely that protected water supply pipes will be required at the site.

## 2 Introduction

- 
- 2.1 Objectives
  - 2.2 Client instructions and confidentiality
  - 2.3 Site location and scheme proposals
  - 2.4 Report format and investigation standards
  - 2.5 Status of this report
  - 2.6 Report distribution
- 

### 2.1 Objectives

- 2.1.1 This report describes a ground investigation carried out for the Phase 1 area of a proposed residential development located on land east of Chipping Lane, Longridge, Preston PR3 2NA.
- 2.1.2 The objective of the ground investigation was to establish ground conditions at the site, sufficient to identify possible foundation solutions for the development and provide parameters necessary for the design and construction of foundations.
- 2.1.3 The investigation included an evaluation of potential chemical and gaseous contamination of the site leading to the production of a risk assessment in relation to contamination.
- 2.1.4 A Phase 1 Desk Study Assessment has been previously undertaken for the site by Curtins Consulting Ltd (ref EB1355/GL/3692 Revision A dated April 2014). A copy of their report is presented in Appendix L. We understand that we have the benefit of using such information and have provided a summary of the data in Section 3 of this report. This will also form a basis for our interpretative chemical and gaseous contamination assessments presented in Sections 8 and 9 respectively.
- 2.1.5 The investigation has also been produced to support a planning application for the site (ref 3/2014/0764) by satisfying National Planning Policies Framework sections 120 and 121.

### 2.2 Client instructions and confidentiality

- 2.2.1 The investigation was carried out and reported in February 2016 acting on instructions received from our client Barratt Homes (Manchester).
- 2.2.2 This report has been prepared for the sole benefit of our above named instructing client, but this report, and its contents, remains the property of Soiltechnics Limited until payment in full of our invoices in connection with production of this report.
- 2.2.3 Our original investigation proposals were outlined in our correspondence to Barratt Homes of 20<sup>th</sup> January 2016. The investigation generally followed our original investigation proposals. The investigation process was also determined to maintain as far as possible the original investigation budget costs.

## 2.3 Site location and scheme proposals

- 2.3.1 The National Grid reference for the site is 360165, 438010. A plan showing the location of the site is presented on Drawing 01, with the extent of development phases presented on Drawing 02a.
- 2.3.2 We understand the scheme in its entirety will comprise the construction of up to 363 dwellings within what is termed Phases 1 and 2 (refer to Drawing 02a for details), with associated landscaping, gardens, hardstanding and access roads. This report refers to the Phase 1 area only in which 118 dwellings are proposed.
- 2.3.3 We have received layout drawings of the proposed scheme with the layout presented on Drawing 03.

## 2.4 Report format and investigation standards

- 2.4.1 Sections 2 to 6 of this report describe the factual aspects of the investigation with Section 7 presenting an engineering assessment of the investigatory data. Section 8 provides a risk assessment of chemical contamination based on readily available historic records, inspection of the soils and laboratory testing. Section 9 provides a similar risk assessment in relation to gaseous contamination with Section 10, a risk assessment relating to construction materials likely to be in contact with the ground. Section 11 discusses issues relating to classification of waste soils for disposal and reuse.
- 2.4.2 This investigation integrates both contamination and geotechnical aspects. The investigation was carried out generally, and where practical following the recommendations of BS EN 1997:2 2007 '*Eurocode 7 – Geotechnical Design – Part 2: Ground Investigation and Testing*'. The investigation process also followed the principles of BS10175: 2011 '*Investigation of potentially Contaminated Sites – Code of Practice*'. The following elements, defined in BS10175, have been completed and incorporated in this report.
- a) Phase I Preliminary investigation (desk study) – review of existing Phase 1 report undertaken by Curtins Consulting Ltd and site reconnaissance undertaken by Soiltechnics Ltd
  - b) Phase II Exploratory and main (intrusive) investigations
- 2.4.3 The extent and result of the preliminary investigation (desk study) undertaken by Curtins Consulting Ltd, in addition to site reconnaissance undertaken by Soiltechnics Ltd, is reported in Section 3. Fieldwork combined the exploratory investigation and main investigation stages into one phase with the extent of these works described in Sections 4 and 6 of this report. Any supplementary investigations deemed necessary are identified in Section 12. Section 13 provides information on any remedial strategy and specification if required.

## 2.5 Status of this report

- 2.5.1 This report is final based on our current instructions.



- 2.5.2 This investigation has been carried out and reported based on our understanding of best practice. Improved practices, technology, new information and changes in legislation may necessitate an alteration to the report in whole or part after publication. Hence, should the development commence after expiry of one year from the publication date of this report then we would recommend the report be referred back to Soiltechnics for reassessment. Equally, if the nature of the development changes, Soiltechnics should be advised and a reassessment carried out if considered appropriate.

## 2.6 Report distribution

- 2.6.1 This report has been prepared to assist in the design and planning process of the development and normally will require distribution to the following parties, although this list may not be exhaustive:

**Table summarising parties likely to require information contained in this report**

Party	Reason
Client	For information / reference and cost planning
Developer / Contractor / project manager	To ensure procedures are implemented, programmed and costed
Planning department Environment Agency	Potentially to discharge planning conditions If ground controlled waters are affected and obtain approvals to any remediation strategies
Independent inspectors such as NHBC / Building Control	To ensure procedures are implemented and compliance with building regulations
Project design team	To progress the design
Principal Designer (PD)	To advise in construction risk identification and management under the Construction (design and management) regulations

**Table 2.6**

## 3 Desk study information and site observations

---

3.1	General
3.2	Description of the site
3.3	Injurious and invasive weeds and asbestos
3.4	History of the site
3.5	Geology and geohydrology of the area
3.6	Landfill and infilled ground
3.7	Radon
3.8	Flood risk
3.9	Enquiries with Statutory Undertakers
3.10	Enquiries with Local Authority Building Control and Environmental Health Officers

---

### 3.1 General

3.1.1 A Phase 1 Detailed Desk Top Study has been previously undertaken for the site by Curtins Consulting Ltd (reference EB1355/GL/3692, revision A, issue 01, dated 14<sup>th</sup> April 2014). A copy of their report is presented in Appendix L. We understand that we have the benefit of using such information and have provided a summary of the data in following paragraphs, together with our own site observations. It should be noted that we have tailored the information to suite the current site boundary for the Phase 1 development area, which is shown in a slightly different position in the Curtins report.

### 3.2 Description of the site

3.2.1 The site is positioned on the north-western outskirts of Longridge, Preston, at an elevation of between approximately 103m and 110m AOD and with the topography of the site falling in a north-westerly direction. The site, approximately 5.4Ha in size, comprised three open grassed fields separated by mature hedgerows and sporadic trees between approximately 2m and 15m in height. It is understood that the land is currently used by livestock for grazing. Localised ponding of surface water was evident across the site. Higgin Brook is recorded onsite, flowing along the boundary between the central and eastern most parcels of land in a north-easterly direction, then flowing in a north-westerly direction along the northern site boundary. Each parcel of land onsite was accessed via a gate within the hedge line. A series of manhole covers were also present in the eastern most parcel of land associated with a surface water sewer which outfalls into Higgin Brook onsite.

3.2.2 The site was bound to the north and east by further open grassed fields; a cricket ground was also present to the north. Chipping Lane formed the western site boundary, beyond which were recreational grounds. A small garage, a large supermarket and a small number of residential properties were present to the south of the site.

3.2.3 A plan showing existing site features and location of exploratory points is presented as Drawing 02b.

### 3.3 Injurious and invasive weeds and asbestos

#### 3.3.1 Injurious and invasive weeds

3.3.1.1 The following weeds are controlled under the Weeds Act 1959:

- Common ragwort
- Spear thistle
- Creeping (or field) thistle
- Broad-leaved dock
- Curled dock

3.3.1.2 Whilst it is not an offence to have the above weeds growing on your land, you must:

- Stop them spreading to agricultural land, particularly grazing areas or land used for forage, like silage and hay
- Choose the most appropriate control method for the your site
- Not plant them in the wild

Should you allow the spread of these weeds to another parties land, Natural England could serve you with an Enforcement Notice. You can also be prosecuted if you allow animals to suffer by eating these weeds.

3.3.1.3 In addition to the above, you must not plant in the wild or cause certain invasive and non-native plants to grow in the wild as outlined in the Wildlife and Countryside Act 1981. It is an offence under section 14(2) of the act to '*plant or otherwise cause to grow in the wild*' any plants listed in schedule 9, part II. This can include moving contaminated soil or plant cuttings. The offence carries a fine or custodial sentence of up to two years. The most commonly found invasive, non-native plants include:

- Japanese knotweed
- Giant hogweed
- Himalayan balsam
- Rhododendron ponticum
- New Zealand pigmyweed

You are not legally obliged to remove these plants or to control them. However, if you allow Japanese knotweed to spread to another party's land, you could be prosecuted for causing a private nuisance.

3.3.1.4 The presence of such weeds on site may have considerable effects on the cost / timescale in developing the site. Japanese knotweed can cause significant damage to buildings, roads and pavements following development, if untreated prior to development.

3.3.1.5 Our investigations exclude surveys to identify the presence of injurious and invasive weeds. We did not observe any obvious evidence the above species; however, we recommend specialists in the identification and procedures to deal with injurious and invasive weeds are appointed prior to commencement of any works on site or, if appropriate, purchase of the site.

### 3.3.2 Asbestos

3.3.2.1 Our investigations exclude surveys to identify the presence or absence of asbestos on site. It should be noted, however, that where intrusive investigations were undertaken we did not observe any obvious evidence of potential asbestos containing materials. This information does not constitute a site-specific risk assessment and we recommend specialists in the identification and control / disposal of asbestos are appointed prior to commencement of any works on site or, if appropriate, purchase of the site.

3.3.2.2 The presence of asbestos on site may have considerable effects on the cost / timescale in developing the site. There is good guidance in relation to asbestos available on the Health and Safety Executive (HSE) website.

## 3.4 History of the site

3.4.1 The recent pertinent history of the site, updated from the Curtins summary to reflect the current site boundary, is presented in the following table:

Summary description of site history		
Date	On site	Off site
1847	The site was occupied by three fields	The site was surrounded by tree-lined fields containing a number of small ponds and marshy areas; the closest was c.20m to the north-east of the site. The site was bounded by roads to the south and west; on the western side of the road to the west was Alston Arms Public House
1893	Higgin Brook crossed the site from the south to the north-east and formed part of the eastern and northern site boundaries	Pitt Street Mills (Corn & Bone) and a smithy were constructed c.25m to the south of the site. An iron and brass foundry was present c.150m to the west of the site. The closest pond to the site was adjacent to the site's north-eastern boundary
1895	No significant changes	No significant changes
1912	No significant changes	Sheep pens were constructed to the north of Alston Arms Public House
1913-4	No significant changes	No significant changes
1932	No significant changes	The Pitt Street Mills (Corn & Bone) and smithy buildings became a Bobbin works. The pond adjacent to the site's north-eastern boundary was no longer shown to contain water
1956	No significant changes	Residential properties were constructed to the south of the site
1961-7	No significant changes	The sheep pens were no longer shown. The Bobbin works was redeveloped as a garage and Ashley Dairy
1968	No significant changes	The iron and brass foundry was labelled as a works
1970	No significant changes	No significant changes
1975	No significant changes	Ashley Dairy was redeveloped

Summary description of site history		
Date	On site	Off site
1975-1996	No significant changes	No significant changes
2001	No significant changes	Ashley Dairy was demolished and replaced with a superstore; the garage was redeveloped, but retained. A cricket ground and pavilion were constructed adjacent to the north-eastern site boundary. The former iron and brass foundry was labelled as a depot
2006-2013	No significant changes	No significant changes

**Table 3.4.1**

3.4.2 In addition to the historical map information presented in the Curtins report, readily available historical aerial imagery of the site indicates that a track crossed the western most parcel of land at the site from Chipping Lane at some point before 2001. It entered near the northern end of the field, crossing in an easterly/south-easterly direction. The track was not visible during our site visit.

### 3.5 Geology and geohydrology of the area

#### 3.5.1 Geology of the area

3.5.1.1 The geology of the area, updated from the Curtins summary to reflect the current site boundary, is presented in the following table:

Summary of geology and likely aquifer-containing strata					
Stratum	Bedrock or superficial	Approximate thickness	Typical soil type	Likely permeability	Aquifer designation
Devensian Till	Superficial	>5m	Clay with silt and sand	Low	Unproductive strata (r)
Bowland Shale Formation	Bedrock	Up to 200m	Mudstone, siltstone with sandstones	Low to moderate	Secondary A aquifer (r)

**Table 3.5.1**

(r) recorded aquifer designation

(a) assumed aquifer designation

3.5.1.2 Unproductive strata are defined as deposits exhibiting low permeability with negligible significance for water supply or river base flow. Unproductive strata are generally regarded as not containing groundwater in exploitable quantities.

3.5.1.3 Secondary A aquifers are predominantly permeable layers capable of supporting water supplies at a local, rather than strategic, scale. In some cases, Secondary A aquifers can form an important source of base flow to rivers.

### 3.5.2 Water abstractions

3.5.2.1 There are no potable groundwater abstraction licences within 2km of the site. The only surface water abstraction within a 2km radius of the site is associated with field drains located approximately 445m to the south of the site. Details of the water's use are not supplied. There are two groundwater abstractions within a 2km radius of the site. They are both associated with Singletons Dairy (Mill Farm, Preston) and are located approximately 890m and 975m to the south of the site. The abstracted water is used for general purposes.

3.5.2.2 The site is not located within a zone protecting a potable water supply abstracting from a principal aquifer (i.e. a source protection zone).

### 3.5.3 Coal mining and brine extraction

3.5.3.1 The site is not recorded to be within an area affected by past or present coal mining, minerals worked in association with coal, or brine extraction (within the Cheshire Brine Compensation District). The site does not lie within a coal mining referral area and, as such, a Coal Authority report is not required.

### 3.5.4 Shallow mining and natural subsidence hazards

3.5.4.1 The British Geological Survey presents hazard ratings for shallow mining and natural subsidence hazards. The site has the following ratings:

**Table summarising mining and subsidence hazards**

Hazard	Rating
Mining hazard in non-coal mining areas	Highly unlikely
Potential for collapsible ground stability hazard	Very low / no hazard
Potential for compressible ground stability hazard	Moderate / no hazard
Potential for ground dissolution stability hazard	Low / very low
Potential for landslide ground stability hazard	Very low
Potential for running sand ground stability hazard	Low / very low
Potential for shrinking or swelling clay ground stability hazard	Very low

**Table 3.5.4**

3.5.4.2 The moderate potential for compressible ground stability hazards is likely to be associated with the deposits of cohesive Devensian Till onsite.

### 3.5.5 Borehole records

3.5.5.1 The British Geological Survey (BGS) retains records of boreholes formed from ground investigations carried out on a nationwide basis. However, there are no BGS borehole records in the vicinity of the site.

### **3.6 Landfill and infilled ground**

- 3.6.1 Within a 2km radius of the site, there are no BGS recorded or historical landfill sites; however, there are two registered landfill sites. Lords Delph (Forty Acre Lane, Longridge) is located approximately 750m to the east of the site and has been accepting non-biodegradable waste since at least 1982. Chapel Hill Quarry is located approximately 960m to the south of the site and accepted non-biodegradable waste; in 1992, the site was recorded as dormant.
- 3.6.2 In addition, we have reviewed old Ordnance Survey maps and there is no obvious evidence of significant quarrying in the area, other than a small number of BGS mineral sites, recorded between 400m and 850m of the subject site which exploited the underlying clays and grits. The geological map of the area indicates areas of infilled ground which approximately coincide with such areas.

### **3.7 Radon**

- 3.7.1 Envirocheck uses the British Geological Survey database to review reported radon levels in the area in which the site is located, to establish recommended radon protection levels for new dwellings. The database presented in the Curtins report indicates that the site is located in an area where no protection is considered necessary.
- 3.7.2 Building Research Establishment (BRE) publication BR211 '*Radon: guidance on protective measures for new buildings*' (2007) applies to all new buildings, conversions and refurbishments, whether they be for domestic or non-domestic use.
- 3.7.3 It is noteworthy that the BRE and BGS / HPA information is based on statistical analysis of measurements made in dwellings, in combination with geological units which are known to emit radon. Therefore there is a risk that actual radon levels at the site will exceed the levels assessed by the BGS / HPA / BRE. Currently, the only true method of checking actual radon levels is by measurement within a building on the site over a period of several months. It should be noted that it is not currently a requirement of the Building Regulations to test new buildings for radon; however, the BRE recommends testing on completion or occupation of all new buildings (domestic and non-domestic), extensions and conversions. Should you wish to undertake radon monitoring following completion of the development, we can provide proposals.

### **3.8 Flood risk**

- 3.8.1 Based on the information provided within the Curtins report, the site is not located within a fluvial or tidal flood plain. It should be noted that this information does not constitute a site-specific Flood Risk Assessment (FRA) and that a full FRA may be required for the development to support a planning application or to satisfy planning conditions.

### **3.9 Enquiries with Statutory Undertakers**

3.9.1 We have been provided with the following Statutory Undertaker (SU) records in order to avoid damaging their apparatus during our fieldwork activities:

- a) BT Openreach
- b) Electricity North West
- c) ESP Utilities Group
- d) National Grid Gas
- e) United Utilities

Copies of these records are presented in Appendix J. These records have been obtained solely for the purposes described above.

3.9.2 Normally Statutory Undertakers' drawings record the approximate location of their services. We recommend further on-site investigations be undertaken to confirm the position of the apparatus and thus establish the effect on the proposed development and the necessity or otherwise for the permanent or temporary diversion of the service to allow the construction of the development to safely and successfully proceed.

3.9.3 It should be noted that a United Utilities surface water sewer crosses the south-eastern part of the site and discharges into Higgin Brook. In addition, two spans of an Electricity North West overhead electricity line cross the south-western part of the site, to the cricket ground. Thirdly, an underground BT line runs along the western boundary of the site. We are not aware that the supply to such services has been capped off-site and, as such, they should be treated as live until further information indicates otherwise.

3.9.4 It should be noted that Statutory Undertakers' records normally exclude private services.

### **3.10 Enquiries with Local Authority Building Control and Environmental Health Officers**

3.10.1 We have contacted the Local Authority Building Control and are awaiting a response. We will update this report if anything of concern arises.

3.10.2 We have contacted the Local Authority Environmental Health Officer, who has confirmed that no gas monitoring is required on this site, due to the limited number of sources and pathways in the area (refer to Section 9 for further details). A copy of their correspondence is presented in Appendix K.



## 4 Fieldwork

- 
- 4.1 General
  - 4.2 Site restrictions
  - 4.3 Exploratory trial pits
  - 4.4 Driven tube sampling
  - 4.5 Dynamic probing
  - 4.6 Sampling strategies
- 

### 4.1 General

4.1.1 Fieldwork was carried out on 3<sup>rd</sup> and 4<sup>th</sup> February 2016 and comprised the following activities:-

- Excavation of twenty exploratory trial pits
- Excavation of seven exploratory boreholes using driven tube sampler drilling techniques
- Dynamic cone penetration testing undertaken in three locations
- Infiltration testing undertaken in two trial pits
- Installation of gas/groundwater monitoring standpipes within four boreholes

4.1.2 A plan of the site showing observed/existing site features and position of exploratory points is presented on Drawing 02b. The position of exploratory points relative to site development proposals is presented on Drawing 03. The position of exploratory points shown on these plans is approximate only and confirmation of these positions is subject to dimensional surveys, which is considered outside our brief.

4.1.3 The extent of fieldwork activities and position of exploratory points were determined by Soiltechnics.

4.1.4 Exploratory points were positioned to avoid known locations of underground services, to avoid possible location of proposed foundations but were also positioned to provide a reasonable coverage of the site. Prior to commencement of exploratory excavations an electronic cable locating tool was used to scan the area of the excavation. If we received a response to this equipment then the excavation would be relocated.

4.1.5 All soils exposed in excavations were described in accordance with BS EN ISO 14688 '*Identification and Classification of soil*'.

### 4.2 Site restrictions

4.2.1 No significant site restrictions were encountered during investigations with the exception that trial pit excavations were undertaken using tracked plant due to waterlogged nature of the site and care was taken to avoid the 375mm diameter surface water sewer which cuts across the eastern most parcel of land and outfalls into Higgin Brook.

### 4.3 Exploratory trial pits

- 4.3.1 Trial pits TP01 to TP20 were excavated to a maximum depth of 4.7m using a 360° tracked excavator. The excavations were backfilled with excavated material compacted using the back of the excavator bucket. Whilst we attempted to reinstate the excavation to its original condition the soils could not be fully compacted into the trial pit and thus the soils were left proud of the ground surrounding the pit to allow for short-term settlement of the backfill. A Geotechnical Engineer supervised the excavations.
- 4.3.2 Sampling and logging was carried out as trial pit excavations proceeded but were not entered at depths exceeding 1.2m, or where trial pit sides were deemed unstable. The density of granular soils encountered in excavations was gauged by the ease of excavation by spade or penetration of a geological pick.
- 4.3.3 Soil samples for subsequent laboratory determination of concentration of chemical contaminants were taken from the sides of trial pits using clean stainless steel equipment and stored in new plastic containers, which were labelled and sealed. The stainless steel sampling equipment was cleaned with deionised water between sampling points. Samples from below access depth into trial pits were taken as a sub sample from soil contained in the excavator bucket, discarding any soil, which may have been in contact with the bucket. If as a consequence of visual or olfactory evidence, a sample was suspected to be contaminated by organic material, the sample was stored in an amber glass jar with a PTFE sealing washer.
- 4.3.4 Soil samples for subsequent 'classification' laboratory testing were taken from the side of trial pits or from bulk samples taken from the excavator bucket. The sample was placed in a plastic bag and subsequently sealed and labelled. Samples for moisture content determination were placed in sealable tubs and appropriately labelled. Moisture content samples were taken to the laboratory for testing within 24 hours of sampling.
- 4.3.5 Soil samples were obtained to meet quality class 3 to 5 as described in BS EN 1997-2:2007. Sample sizes were appropriate for the laboratory test being considered.
- 4.3.6 A hand held shear vane was used where possible to provide a measure of the undrained shear strength of cohesive soils exposed in excavations. The vane test was carried out in the sides and floor of trial pits by access into the trial pit to depths of 1.2 metres. At depths in excess of 1.2 metres the tests were undertaken using extension rods to a maximum depth of 3.4 meters or by carrying out tests on intact clods of cohesive soils (exceeding 0.3m x 0.3m x 0.3m) removed from the trial pit using the excavator bucket. The apparatus reads to a maximum shear strength of 213kN/m<sup>2</sup> following conversion of the readout or 'division' taken from the instrument. Conversion is either undertaken using the calibration chart or by multiplying the division by the shear strength constant supplied with the instrument. The results are reported in columns to the right of the trial pit record. The shear vane is not a reliable tool for assessing insitu shear strength of stony or sandy cohesive soils.

- 4.3.7 A pocket penetrometer was also used in the cohesive soils encountered. This tool is deemed to measure the apparent ultimate bearing capacity of the soil under test. The pocket penetrometer is calibrated in  $\text{kg}/\text{cm}^2$ . The reading can be approximately converted to equivalent undrained shear strength by multiplying the results by a factor of 50. Tests were carried out in the sides of trial pits when access can be safely achieved otherwise testing was carried out on excavated intact clods. The results are reported in columns to the right of trial pit results. The pocket penetrometer is not covered by British Standards. This tool has the advantage that it can be used to determine the approximate insitu undrained shear strength of stony cohesive soils.
- 4.3.8 A summary of hand held shear vane and pocket penetrometer results obtained from the cohesive soils encountered in exploratory excavations are presented in graphical format on Drawing 04.
- 4.3.9 Trial pit records are presented in Appendix C.
- 4.3.10 Soil infiltration tests were carried out in trial pits TP04 and TP09 at depths of between 1.25m and 1.7m. Infiltration tests were carried out following the procedures described in the Building Research Establishment (BRE) Digest 365 (2007) "Soakaway Design", with records of test results presented in Appendix E. Water placed in each trial pit did not dissipate and soils are considered to be effectively impermeable.
- 4.4 Driven tube sampling**
- 4.4.1 Boreholes DTS01 to DTS07 were formed using driven tube sampling equipment. Driven tube sampling comprises driving 1m long steel sample tubes which are screw coupled together or coupled to extension rods and fitted with a screw on cutting edge. The sample tubes are of various diameters, generally commencing with 100mm and reducing, with depth, to 50mm and include a disposable plastic liner which is changed between sampling locations in order to limit the risk of cross contamination. On completion of excavation the liner containing the sample is cut open and the soil sample logged by a geo-environmental engineer.
- 4.4.2 Samples for determination of the concentration of chemical contaminants are taken from samples obtained in the disposable tubes as sub-samples using stainless steel sampling equipment, which is cleaned with de-ionised water.
- 4.4.3 The driven tube sampler obtains samples under category A allowing laboratory test quality classes 3 to 5 as described in BS EN ISO 22475-1:2006.
- 4.4.4 A pocket penetrometer was used in the cohesive soils retrieved from the boreholes. This tool is deemed to measure the apparent ultimate bearing capacity of the soil under test. The pocket penetrometer is calibrated in  $\text{kg}/\text{cm}^2$ . The reading can be approximately converted to an equivalent undrained shear strength by multiplying the results by a factor of 50. The results are reported on borehole records. The pocket penetrometer is not covered by British Standards.

4.4.5 A summary of pocket penetrometer results obtained from the cohesive soils retrieved from the boreholes are presented in graphical format on Drawing 04.

4.4.6 Combined gas and groundwater monitoring standpipes were installed in boreholes DTS02, DTS03, DTS05 and DTS06. The standpipes were installed following the recommendations of BS EN ISO 22475-1:2006 '*Geotechnical Investigation and Testing – Sampling methods and groundwater measurements – Part 1: Technical Principles for execution*' and BS8576:2013 '*Guidance on investigations for ground gas – Permanent gases and Volatile Organic Compounds (VOCs)*'. Details of the standpipe installation are recorded on Drawing 05.

4.4.7 Records of boreholes formed using driven tube sampling techniques are presented in Appendix D.

## 4.5 Dynamic cone penetration testing

4.5.1 Dynamic Cone Penetration (DCP) testing was carried out in three locations. Dynamic Cone Penetration testing consists of driving a 50mm diameter, 90° cone into the ground, via an anvil and extension rods with successive blows of a freefall hammer. The number of blows required to drive the cone each successive 100mm (N100) is recorded.

4.5.2 Dynamic Cone Penetration testing was carried out following BS EN ISO 22476-2:2005 and the apparatus used was categorised as 'Super heavy' (DPSH-B) in accordance with the standard.

4.5.3 Dynamic cone penetration test data is presented in graphical format on Drawing 05.

## 4.6 Sampling strategies

### 4.6.1 Geotechnical

4.6.1.1 In general we adopted a judgemental sampling strategy in relation to geotechnical aspects of the investigation. The location and frequency of sampling was carried out in consideration of the following:-

- i) Topography
- ii) Geology (including Made Ground)
- iii) Nature of development proposals

### 4.6.2 Environmental

4.6.2.1 Details of sampling with respect to contamination issues are described in Section 8.

### 4.6.3 Sample retention

4.6.3.1 Samples are stored for a period of one month following issue of this report unless otherwise required.

## 5 Ground conditions encountered

---

5.1	Soils
5.2	Topsoil
5.3	Groundwater

---

### 5.1 Soils

5.1.1 Each exploratory excavation encountered a similar profile of soils considered to be Topsoil overlying Devensian Till deposits.

5.1.2 Topsoil deposits were generally encountered as brown and dark brown slightly silty to silty, slightly sandy to sandy organic clay with rootlets, locally also encountered as a dark brown very clayey organic sand. Topsoil was encountered to depths between 0.2m and 0.6m below existing surface levels.

5.1.3 Devensian Till deposits were encountered as cohesive soils across the site, comprising low to very high strength brown mottled grey and orange brown/grey, slightly silty to silty, slightly sandy, slightly gravelly clay in the initial 1m-1.5m below surface level. Below such depths deposits generally exhibit an increase in shear strength and trend towards a brown mottled grey, dark brown and reddish brown colour with varying amounts of silt, sand and gravel. Locally, shear strengths were noted to reduce in value below depths of 2.5m-3.0m (refer to Drawing 04). Furthermore, suspected reworked Devensian Till deposits were noted in borehole DTS01 to a depth of 2.1m, based on soils exhibiting lower than average shear strengths from surface in comparison to surrounding soils.

### 5.2 Topsoil

5.2.1 As a practice we have adopted the following policy for description of Topsoil. If surface soils exhibit a visually significant organic content and darker colour than the soils it overlies (which are considered to be naturally deposited) then we will describe the soil as Topsoil. In some cases it is difficult to visually distinguish the interface between Topsoil and subsoils below, which may also exhibit an organic content, and in such cases we will adopt an estimate of the interface but may also use the terms 'grading into' with some defining depths.

5.2.2 If 'Topsoil' deposits include materials such as ash, brick and other man made materials, or the topsoil overlies Made Ground deposits we will term the material 'Made Ground', even though it may still be able to support vegetable growth, and potentially reused as Topsoil.

5.2.3 Topsoil can be classified following a number of test procedures as described in BS3882: 2007 '*Specification for Topsoil and Requirements for use*', to allow its uses to be determined. We do not carry out such testing unless specifically instructed to do so.

## 5.3 Groundwater

5.3.1 Groundwater inflows were observed in some of the exploratory excavations. A summary of our observations is tabulated below:

**Table summarising groundwater observations**

Exploratory point	Depth (m) below ground levels	Observations
TP03	1.5m	Minor seepage, in sufficient to record depth in base of trial pit 10mins after completion
TP04	1.1m	Minor seepage, in sufficient to record depth in base of trial pit 10mins after completion
TP05	2.6m	Minor seepage, in sufficient to record depth in base of trial pit 10mins after completion
TP06	2.5m	Minor seepage, in sufficient to record depth in base of trial pit 10mins after completion
TP07	2.0m	Minor seepage, in sufficient to record depth in base of trial pit 10mins after completion

**Table 5.3.1**

5.3.2 It should be noted that water levels will vary depending generally on recent weather conditions and only long term monitoring of levels in standpipes will provide a measure of seasonal variations in groundwater levels.

## 6 Laboratory testing

- 
- |     |                        |
|-----|------------------------|
| 6.1 | Classification testing |
| 6.2 | Chemical testing       |
- 

### 6.1 Classification testing

6.1.1 Laboratory testing was carried out in accordance with BS1377: 1990 "Methods of Test for Soils for Civil Engineering Purposes" and limited to determination of

- i) the liquid limit (one point cone penetrometer, method 4.4)
- ii) the plastic limit and plasticity index (method 5)

6.1.2 Laboratory testing was carried out by an independent specialist testing house, which operates a quality assurance scheme. Copies of laboratory test result certificates are presented in Appendix F.

### 6.2 Chemical testing

6.2.1 Laboratory testing was carried out as deemed necessary and carried out using the following techniques:

- Using inductively coupled plasma mass spectrometry (ICP-MS), determination of concentration of metals, semi-metals and soluble sulphate
- Using gas chromatography flame ionisation detection methods (GC-FID), determination of concentration of petroleum hydrocarbons (TPH)
- Using gas chromatography flame ionisation detection methods (GC-FID), determination of concentration of polycyclic aromatic hydrocarbons (PAH)
- Using gas chromatography mass spectrometry (GS-MS), determination of the concentration of Volatile Organic Compounds (VOCs) and Semi-Volatile Organic Compounds (SVOCs)
- Using electromagnetic measurement, determination of pH

6.2.2 Laboratory testing was carried out by an independent specialist testing house, which operates a quality assurance scheme. Copies of laboratory test result certificates are presented in Appendix G.

## 7 Engineering assessment

- 
- 7.1 General description of the development
  - 7.2 Building foundation design and construction
  - 7.3 Influence of trees and other major vegetation
  - 7.4 Ground floor construction
  - 7.5 Foundation and Service trench excavations
  - 7.6 Infiltration potential
  - 7.7 Pavement foundations
- 

### 7.1 General description of the development

7.1.1 The following assessments are made on the investigatory data presented in the preceding sections of this report and are made with reference to the specific nature of the development. Should scheme proposals change then it may be necessary to review the investigation and report.

7.1.2 We understand the scheme in its entirety will comprise the construction of up to 363 dwellings within what is termed Phases 1 and 2 (refer to Drawing 02a for details), with associated landscaping, gardens, hardstanding and access roads. The following assessment refers to the Phase 1 area only, in which 118 dwellings are proposed.

### 7.2 Building foundation, design and construction

7.2.1 Definitions of geotechnical terms used in the following paragraphs are provided in Appendix A.

#### 7.2.2 Ground conditions

7.2.2.1 A detailed summary of ground conditions is provided in Section 5. Essentially ground conditions comprised of Topsoil overlaying cohesive Devensian Till deposits, the latter comprising low to very high strength brown mottled grey and orange brown/grey clay in the initial 1m-1.5m below surface level. Below such depths deposits generally exhibit an increase in shear strength and trend towards a brown mottled grey, dark brown and reddish brown colour with varying amounts of silt, sand and gravel. Locally, shear strengths were noted to reduce in value below depths of 2.5m-3.0m (refer to Drawing 04).

7.2.2.2 Suspected reworked Devensian Till deposits were also noted in borehole DTS01, extending to a depth of 2.1m below existing surface levels, which exhibited lower than average shear strengths from surface level in comparison to surrounding soils. It is possible that such soils are associated with a former track which is only evident on historical aerial imagery of the site, or long term water logging of near surface soils. Foundations will require deepening beyond the minimum recommended depth within this area (discussed in further detail below).



7.2.2.3 In addition to borehole DTS01, near surface naturally deposited Devensian Till also exhibited lower than average shear strengths in other localised areas of the site, associated with boreholes DTS03 to DTS06, and trial pits TP01, TP04 and TP07. Soft and low strength clay soils were encountered to depths of between 1.0m to 2.0m. Again, this may be associated with long term waterlogging of near surface soils and subsequently foundations will require deepening beyond the minimum recommended depth within these areas (discussed in further detail below).

### 7.2.3 Foundation solution

7.2.3.1 In our opinion naturally deposited Devensian Till will adequately support proposed buildings on concrete strip/trench fill foundations. Based on laboratory determination of plasticity and following National House Building Council (NHBC) Standards Chapter 4.2, we recommend foundations extend to a minimum depth of 0.9m below existing or proposed ground levels whichever gives the deeper founding level. In all cases we recommend foundation excavations fully penetrate any reworked natural soils and natural soils exhibiting lower than average shear strengths and, extend into the Devensian Till by a minimum of 0.1m into the naturally deposited soils, subject to an overall minimum foundation depth of 0.9m. It should be noted that there are a number of trees and major vegetation along field boundaries which may require foundation depths exceeding the minimum depth defined above. Further guidance on this is provided in the following report paragraphs.

7.2.3.2 Laboratory testing indicates the Devensian Till deposits are plastic, thus our assessment of bearing values are based on the assumption that these soils predominantly exhibit cohesion. Calculations, based on a conservative undrained shear strength of say 60kN/m<sup>2</sup> (derived from measured insitu shear strengths taken below proposed founding levels – refer Drawing 04) indicates the following bearing values for strip/trench fill foundations:-

Width (m)	Ultimate bearing value kN/m <sup>2</sup>	Presumed bearing value kN/m <sup>2</sup>	Allowable bearing pressure kN/m <sup>2</sup>
0.45	445	160	150
0.6	420	150	140
0.75	405	145	135
1.0	390	140	130

Table 7.2.3.2

7.2.3.3 The presumed bearing value has been derived from the ultimate bearing value by applying a factor of safety of 3, and the allowable bearing pressure derived to limit total settlement.

- 7.2.3.4 It is difficult to accurately predict the amount of total and differential movement caused by consolidation of the foundation supporting subsoils, however, providing the foundation loads do not exceed the allowable bearing pressure provided in the preceding paragraph, we suggest total settlement will be small, and probably less than 25mm. Differential settlements are totally dependent on the variation of foundation loads and consistency of the supporting ground. Assuming the foundation loads are reasonably uniform, we suggest differential settlement is unlikely to exceed say 15mm. It is likely settlement will be fully achieved within 20 years of construction.
- 7.2.3.5 The Devensian Till deposits encountered in exploratory excavations are generally consistent and will provide uniform support to foundations. In the unlikely event foundation excavations encounter a soft area, we recommend foundation excavations continue to locate stiffer soils (see below) or reinforcement introduced into foundation concrete to span the soft area.
- 7.2.3.6 As outlined in Section 7.2.2 above, localised areas of Devensian Till which exhibit lower than average shear strengths have been observed. It is recommended that foundations in such areas are deepened to locate stiffer soils which will reduce the risk of failure of supporting soils. The table below summarises these requirements, with the approximate extent of affected areas also highlighted on Drawing 07:-

Table summarising areas in which foundations will require deepening			
Exploratory point	Extent of low strength clay soils below ground levels (m)	Recommended foundation depth	Observations
DTS01	2.1m	2.2m (0.1m penetration into supporting soils)	Low strength soils characterised by reworked brown mottled grey silty clay with some gravels and dark stained rootlets. Supporting soils consist of very high strength reddish brown mottled grey brown silty clay.
DTS03	1.0m	1.1m (0.1m penetration into supporting soils)	Low strength soils characterised by orangish brown silty clay. Supporting soils consist of high to very high strength brown mottled grey slightly sandy silty clay.
DTS04	1.0m	1.1m (0.1m penetration into supporting soils)	Low strength soils characterised by brown mottled orange and grey slightly silty clay with some gravels and rootlets. Supporting soils consist of high to very high strength dark brown mottled grey slightly gravelly silty clay.
DTS05	1.0m	1.1m (0.1m penetration into supporting soils)	Low strength soils characterised by brown slightly gravelly sandy silty clay with some pseudo fibrous plant remains and dark stained rootlets. Supporting soils consist of very high strength dark brown mottled grey silty clay.
DTS06	1.0m	1.1m (0.1m penetration into supporting soils)	Low strength soils characterised by dark brown mottled grey slightly gravelly sandy clay. Supporting soils consist of high to very high strength brown mottled grey slightly gravelly clay.

Table 7.2.3.6

**Table summarising areas in which foundations will require deepening**

Exploratory point	Extent of low strength clay soils below ground levels (m)	Recommended foundation depth	Observations
TP01	1.0m	1.1m (0.1m penetration into supporting soils)	Low strength soils characterised by brownish grey silty clay. Supporting soils consist of high strength brown slightly silty clay.
TP04	2.0m	2.1m (0.1m penetration into supporting soils)	Low strength soils characterised by brownish grey very silty clay with occasional gravels. Supporting soils consist of very high strength grey slightly silty sandy clay.
TP07	1.2m	1.3m (0.1m penetration into supporting soils)	Low strength soils characterised by brown very sandy clay with occasional gravel. Supporting soils consist of high strength greyish brown slightly sandy silty clay.

**Table 7.2.3.6**

**7.2.3.7**

Based on the table above, and with reference to Drawing 07, we have provided a best indication of likely foundation depths based on investigations completed to date. It is not clear why localised deposits of Devensian Till exhibit marked decreases in shear strength, however, it is likely to be largely associated with prolonged and extensive water logging of the site. We would recommend that further onsite investigations are undertaken in the hatched areas highlighted on Drawing 07 to determine if such low strength soils are laterally/vertically extensive or whether we have recorded a number of anomalous insitu shear strength test results potentially influenced by the presence of water seepages. Alternatively a suitably qualified Geo-Environmental Engineer could attend site during the excavation of trenches for foundations located in the affected areas with the purpose of providing an indication when suitable founding strata has been reached. This would be based on the observations outlined above, in addition to insitu testing of clay soils achieving undrained shear strengths of at least 60kN/m<sup>2</sup>.

**7.3**

**Influence of trees and other major vegetation**

**7.3.1**

**Soil classification and new foundation design**

**7.3.1.1**

The results of plastic and liquid limit determinations performed on samples of the Devensian Till indicate the deposits are soils of medium volume change potential when classified in accordance with National House Building Council (NHBC) Standards, Chapter 4.2. Foundations taken down onto a depth of 0.9m will penetrate the zone of shrinkage and swelling caused by seasonal wetting and drying. Trees and other major vegetation extend this zone and will require deeper foundations. A good guide to this subject is provided in NHBC Standards, Chapter 4.2.

### **7.3.2 New planting**

7.3.2.1 Any planting schemes should also take into account the effect that new trees could have on foundations when they reach maturity. Again a good guide to this subject is provided in NHBC Standards, Chapter 4.2.

### **7.3.3 Tree species identification**

7.3.3.1 There are a number of trees and other major vegetation located along field boundaries at the site. We recommend a qualified Arboriculturist (listed in the Arboricultural Association Directory of Consultants – [www.trees.org.uk](http://www.trees.org.uk)) be appointed to determine the location, height (and mature height) and water demand of all trees/major hedgerows at the site, information, which will be necessary to design foundations in accordance with NHBC Standards, Chapter 4.2.

### **7.3.4 Agricultural crops**

7.3.4.1 It is important to note that the site at the time of our investigations comprised fields surfaced in rough grass and used for grazing livestock. Based on our site reconnaissance, anecdotal information and fieldwork observations, the likelihood that near surface soils have recently supported a crop is considered low.

## **7.4 Ground Floor Construction**

7.4.1 Ground bearing floor slabs can be adopted at this site where buildings are remote from trees and where Topsoil deposits are fully removed within the footprint of the building. We recommend a blanket of good quality compacted granular material be placed prior to construction of the floor slabs.

7.4.1 In areas close to existing major vegetation at the site (or where ground floors are elevated requiring in excess of 600mm of fills) then we recommend the use of a suspended ground floor with a sub floor void determined following NHBC Standards, Chapter 4.2.

## **7.5 Foundation and Service Trench Excavations**

7.5.1 Generally the sides of foundation/service trench excavations will remain stable and we anticipate no significant groundwater inflows will be encountered in any of the excavations. The silty nature of the near surface Devensian Till deposits will render them moisture susceptible with small increases in moisture content promoting rapid deterioration. We recommend, therefore, that as soon as foundation trench excavations are opened foundation concrete be poured as quickly as practically possible.

7.5.2 We recommend any trench excavation requiring human entry is shored as necessary to conform with current best practice, and accepted by the Health and safety Executive (HSE) and in particular, following guidance provided in the HSE publication 'Health and safety in construction (HSG 150)' ([www.hse.gov.uk](http://www.hse.gov.uk)).

## 7.6 Infiltration Potential

- 7.6.1 Based on infiltration testing undertaken in trial pits TP04 and TP09 at the site (refer to Appendix E), the Devensian Till deposits are considered to be effectively impermeable and would not be able to dispose of water using soakaway systems. Alternative means of storm water disposal will be required. Disposal into Higgin Brook could be an option and we understand that the surface water sewer, which cuts across the eastern most parcel of land at the site and outfalls into the brook, serves a similar residential development adjacent to the south-east.

## 7.7 Pavement Foundations

- 7.7.1 It is anticipated that the proposed access road and associated hardstanding areas will be located at or about existing ground levels with formation located on Devensian Till deposits (locally potentially reworked).
- 7.7.2 Equilibrium CBR (California Bearing Ratio) values (with reference to Transport and Road Research Laboratory (TRRL) Report LR1132 '*Structural design of Bituminous Roads*') are derived from knowledge of soil classification data (plasticity index for soils exhibiting cohesion (clay type) and particle size distribution for granular soils), the location of the water table pavement thickness, and weather conditions at the time of construction. It is anticipated that excavations to formation levels will encounter cohesive soils. Assuming an average plasticity index of say 30 for cohesive soils, a low water table, a 'thin' pavement the following equilibrium CBR values are derived for varying construction conditions.

Equilibrium CBR values for differing construction conditions		
Poor	Average	Good
CBR = 3%	CBR = 4%	CBR = 4%

Table 7.7.2

- 7.7.3 It is also possible to derive the 'insitu' CBR value at formation from undrained shear strength data by applying a conversion factor of 23 (refer TRRL laboratory report LR889). Thus adopting pessimistic undrained shear strength of say 50kN/m<sup>2</sup> at formation level (based on insitu shear strength measurements) then an equivalent CBR value can be obtained i.e.

$$\text{Insitu CBR} = \text{undrained shear strength} \frac{50}{23} = 2.17\%$$

- 7.7.4 The 'insitu' CBR derived above, is susceptible to change dependent upon weather conditions during construction. The equilibrium CBR value derived in paragraph 7.7.2 above is an estimate of the CBR value, which will predominate during the life of the pavement. We recommend the insitu CBR of 2.17% derived from shear strength data be utilised for design purposes and reassessed during construction. The fact that the clay subgrade soils are likely to be deemed frost susceptible will probably be the overriding criteria for pavement foundation design purposes. It should also be noted that the thickness of the pavement foundation also relates to the amount and loading from construction traffic, which is discussed in detail in the Transport and Road Research Laboratory (TRRL) Report LR1132 '*Structural design of Bituminous Roads*'.
- 7.7.5 The CBR value based on insitu shear strength test data is relatively low and subsequently pavement formation thicknesses will be need to be increased accordingly. Undertaking further insitu testing (maybe using a TRL DCP probe) along proposed access roads and hardstanding may yield an increase in this value, potentially above 3% which would decrease the required formation thickness and provide associated cost savings.
- 7.7.6 Once formation levels have been established it is recommended that the formation be trimmed and rolled following current requirements of the Highways Agency Specification for Highways Works (clause 616) (refer [www.dft.gov.uk/ha/standards/mchw/vol1](http://www.dft.gov.uk/ha/standards/mchw/vol1)). Such a process will identify any soft areas, which we recommend be either excavated out and backfilled with a suitable well compacted material similar to those exposed in the sides of the resulting excavation, or large cobbles of a good quality stone rolled into the formation to stabilise the 'soft' area.
- 7.7.7 The silty nature of the Devensian Till will render them moisture susceptible with small increases in moisture content giving rise to a rapid loss of support to construction plant. We therefore recommend, as soon as formation is trimmed and rolled, that sub-base is laid in order to avoid deterioration of the subgrade in wet or frosty conditions.

## 8 Chemical contamination

- 8.1 Contaminated land, regulations and liabilities
- 8.2 Objectives and procedures
- 8.3 Development characterisation and identified receptors
- 8.4 Identification of pathways
- 8.5 Assessment of sources of contamination
- 8.6 Initial conceptual model
- 8.7 Laboratory testing
- 8.8 Updated conceptual model
- 8.9 Actions
- 8.10 Risk assessment summary and recommendations
- 8.11 Statement with respect to National Planning Policy Framework
- 8.12 On site monitoring

### 8.1 Contaminated land, regulation and liabilities

#### 8.1.1 Statute

8.1.1.1 Part IIA of the Environment Protection Act 1990 became statute in April 2000. The principal feature of this legislation is that the hazards associated with contaminated land should be evaluated in the context of a site-specific risk based framework. More specifically contaminated land is defined as:

*“any land which appears to the local authority in whose area it is situated to be in such a condition, by reasons of substances in, on or under the land, that:*

- a) *Significant harm is being caused or there is a significant possibility of such harm being caused; or*
- b) *Pollution of controlled waters is being or is likely to be caused”.*

8.1.1.2 Central to the investigation of contaminated land and the assessment of risks posed by this land is that:

- i) **There must be contaminants(s) at concentrations capable of causing health effects (*Sources*).**
- ii) **There must be a human or environmental receptor present, or one which makes use of the site periodically (*Receptor*); and**
- iii) **There must be an exposure pathway by which the receptor comes into contact with the environmental contaminant (*Pathway*).**

8.1.1.3 In most cases the Act is regulated by Borough or District Councils and their role is as follows:

- i) **Inspect their area to identify contaminated land**
- ii) **Establish responsibilities for remediation of the land**

- iii) See that appropriate remediation takes place through agreement with those responsible, or if not possible:
  - by serving a remediation notice, or
  - in certain cases carrying out the works themselves, or
  - in certain cases by other powers
- iv) keep a public register detailing the regulatory action which they have taken

**8.1.1.4** For “special” sites the Environment Agency will take over from the Council as regulator. Special sites typically include:-

- Contaminated land which affects controlled water and their quality
- Oil refineries
- Nuclear sites
- Waste management sites

### **8.1.2 Liabilities under the Act**

**8.1.2.1** Liability for remediation of contaminated land would be assigned to persons, organisations or businesses if they caused, or knowingly permitted contamination, or if they own or occupy contaminated land in a case where no polluter can be found.

### **8.1.3 Relevance to predevelopment conditions**

**8.1.3.1** For current use, Part IIA of the Environmental Protection Act 1990 provides the regulatory regime. The presence of harmful chemicals could provide a ‘source’ in a ‘pollutant linkage’ allowing the regulator (local authority or Environment Agency) to determine if there is a significant possibility of harm being caused to humans, buildings or the environment. Under such circumstances the regulator would determine the land as ‘contaminated’ under the provision of the Act requiring the remediation process to be implemented.

### **8.1.4 Relevance to planned development**

**8.1.4.1** The developer is responsible for determining whether land is suitable for a particular development or can be made so by remedial action. In particular, the developer should carry out an adequate investigation to inform a risk assessment to determine:

- a) Whether the land in question is already affected by contamination through source – pathway – receptor pollutant linkages and how those linkages are represented in a conceptual model
- b) Whether the development proposed will create new linkages e.g. new pathways by which existing contaminants might reach existing or proposed receptors and whether it will introduce new vulnerable receptors, and
- c) What action is needed to break those linkages and avoid new ones, deal with any unacceptable risks and enable safe development and future occupancy of the site and neighbouring land?



**8.1.4.2** Building control bodies enforce compliance with the Building Regulations. Practical guidance is provided in Approved documents, one of which is Part C, '*Site preparation and resistance to contaminants and moisture*' which seeks to protect the health, safety and welfare of people in and around buildings, and includes requirements for protection against harm from chemical contaminants.

**8.1.5 Pollution of controlled waters**

**8.1.5.1** Part IIA of the Environment Protection Act 1990, defines pollution of controlled waters as

*'The entry into controlled waters of any poisonous, noxious or polluting matter or any solid waste matter'*

**8.1.5.2** Paragraphs A36 and A39 of statutory guidance (DETR 2000) further define the basis on which land may be determined to be contaminated land on the basis of pollution of controlled waters.

*'Before determining that pollution of controlled waters is being, or likely to be, caused, the Local Authority should be satisfied that a substance is continuing to enter controlled waters, or is likely to enter controlled waters. For this purpose, the local authority should regard something as being likely when they judge it more likely than not to occur'*

*'Land should not be designated as contaminated land where:*

- a) A substance is already present in controlled waters;*
- b) Entry into controlled waters of that substance from the land has ceased, and*
- c) It is not likely that further entry will take place.*

*Substances should be regarded as having entered controlled waters where:*

- a) They are dissolved or suspended in those waters; or*
- b) If they are immiscible with water, they have direct contact with those waters, or beneath the surface of the waters'*

**8.1.5.3** Controlled waters are defined in statute to be:

*'territorial waters which extend seawards for 3 miles, coastal waters, inland freshwaters, that is to say, the waters in any relevant lake or pond or of so much of any relevant river or watercourse as is above the freshwater limit, and groundwaters, that is to say, any waters contained in underground strata.'*

**8.1.6 Further information**

**8.1.6.1** The above provides a brief outline as regards current statute and planning controls. Further information can be obtained from the Department for the Environment, Food and Rural Affairs (DEFRA) and their Web site [www.defra.gov.uk](http://www.defra.gov.uk).

## 8.2 Objectives and procedures

### 8.2.1 Objectives

8.2.1.1 This report section discusses investigations carried out with respect to chemical contamination issues relating to the site. The investigations were carried out to determine if there are any liabilities with respect to Part IIA of the Environment Protection Act. As stated in Section 2.4.2, the investigation process followed the principles of BS10175: 2011 'Investigation of potentially contaminated sites – Code of Practice', with the investigation combining a desk study (preliminary investigation) together with the exploratory and main investigations (refer BS10175: 2011 for an explanation).

8.2.1.2 This section of the report produces 'Conceptual models' based on investigatory data obtained to date. The conceptual model is constructed by identification of *contaminants* and establishment of feasible *pathways* and *receptors*. The conceptual model allows a *risk assessment* to be derived. Depending upon the outcome of the risk assessment it may be necessary to carry out remediation and/or further investigations with a view to eliminating, reducing or refining the risk of harm being caused to identified receptors. If appropriate, our report will provide recommendations in this respect.

8.2.1.3 Clearly we must consider the current pre-development condition, establishing risks which may require action to render the site safe to all relevant (current) receptors meeting the requirements of current legislation (Part IIA of the Environmental Protection Act 1990).

8.2.1.4 Definition of terms used in the preceding paragraph and subsequent parts of this section of the report are presented in Appendix B.

### 8.2.2 Procedure to assess risks of chemical contamination

8.2.2.1 For the purposes of presenting this section of this report, we have adopted the following sequence in assessing risks associated with chemical contamination.

**Table outlining sequence to assess risk associated with chemical contamination**

Conceptual model element	Contributory information	Outcome
Receptor	Development categorisation	Identification of receptors at risk of being harmed Method of analysing test data Criteria for risk assessment modelling
Pathways	Geology and ground conditions Development proposals	Identification of critical pathways from source to receptor
Source	Previous site history Desk study information Site reconnaissance Fieldwork observations	Testing regime Identification of a chemical source Analysis of test data and other evidence

Table 8.2.2

8.2.2.2 We have adopted, in general, the procedures described in CIRIA C552 'Contaminated land risk assessment - a guide to good practice' in deriving a risk assessment. Initially we have carried out a 'phase 1 assessment' based on desk study information and site reconnaissance, to produce an initial conceptual model and thus a preliminary risk assessment. This model / assessment is then used to target fieldwork activities and laboratory testing, with the results of this part of the investigation used to allow a phase 2 assessment to be produced by updating the conceptual model and refining the risk assessment.

### 8.3 Development characterisation and identified receptors

#### 8.3.1 Site characterisation

8.3.1.1 The nature of the site has a significant influence the likely exposure pathways between potentially contaminated soils and potential receptors. The following table summarises elements which characterise the site based on site observations and desk study information.

Summary of site characteristics		
Element	Source / criteria	Characteristic
Current land use	Observations	Site currently in use as grazing land for livestock. Not accessible to the general public.
Future land use	Advice	Residential development which includes domestic gardens
Site history	Desk study	Recorded as fields from earliest maps.
Geology	Desk study	>5m thickness of Devensian Till deposits with Bowland Shale Formation at depth. Alluvium recorded adjacent to the north-east of the site.
	Site Investigation	>4.7m thickness of Devensian Till deposits. Possible reworked deposits in area of borehole DTS01.
	Aquifer potential	Devensian Till deposits recorded as Unproductive strata. Underlying Bowland Shale recorded as a Secondary A aquifer.
Ground water	Abstractions	There are no potable water abstractions within 1000m of the site. There are two groundwater abstractions within 1000m of the site, the nearest associated with Mill Farm borehole located 889m north west of the site.
	Source protection zone	Site not recorded in source protection zone (SPZ).
Surface waters	Location	The nearest surface water feature is a tertiary river (Higgin Brook) which flows in a north-easterly and north-westerly direction along the field boundary between the central and eastern most parcels of land and then along the northern most boundary of the site.
	Abstractions	There is one surface water abstraction within 1000m of the site located 445m south east associated with a field drain located in Lyndhurst, Longridge.

Table 8.3.1

#### 8.3.2 Identified receptors

8.3.2.1 The principal receptors subject to harm caused by any contamination of the proposed development site are as follows.

Principle Receptor	Detail
Humans	Users of the current site
	End user of the developed site
	Construction operatives and other site investigators
Vegetation	Plants and trees, both before and after development
Controlled waters	Surface waters (Rivers, streams, ponds and above ground reservoirs)
	Ground waters (used for abstraction or feeding rivers / streams etc)
Building materials	Materials in contact with the ground

**Table 8.3.2**

This section of the report assesses those receptors listed above. Section 10 provides a risk assessment in relation to building materials.

### 8.3.3 Human receptors

8.3.3.1 The Contaminated Land Exposure Assessment (CLEA) model can be used to derive guideline values, against which land quality data can be compared to allow an assessment of the likely impacts of soil contamination on humans. The parameters used within the model can be chosen to allow guideline values to be derived for a variety of land uses and exposure pathways. For example, a construction worker is likely to be exposed in different ways and for different durations than an adult in a residential setting.

8.3.3.2 On the basis that the existing site is restricted to farming activities the adult is considered an appropriate current receptor. Following completion of the residential development the critical site user (receptor) is considered to be a child under the age of 6 years. This criterion has been used in the conceptual model for the current and future site use. Our assessment also considers construction operatives as adult receptors.

### 8.3.4 Vegetation receptors

8.3.4.1 Soil contaminants can have an adverse effect on plants if they are present at sufficient concentrations. The effects of phytotoxic contaminations include growth inhibition, interference with natural processes within the plant and nutrient deficiencies.

8.3.4.2 Vegetation is currently present at the site and will remain so following development, in addition to further vegetation proposed as part of the new development. We have therefore considered vegetation a viable receptor.

### 8.3.5 Water receptors

8.3.4.1 The near surface Devensian Till deposits are recorded as unproductive strata and extend to depths beyond 4.7m at the site, with the Bowland Shale Formation deposits at depth recorded as a Secondary A aquifer. The site is not recorded in a source protection zone. Based on the above, given the thickness of Devensian Till groundwater will not be considered a viable receptor. The nearest watercourse to the site is Higgin Brook, which flows through the central part of the site in a north-easterly direction and then along the northern site boundary in a north-westerly direction. Based on such, surface water will be considered a viable receptor.

### 8.3.6 Summary of identified receptors

8.3.6.1 Based on the above assessments, the following table summarises identified and critical receptors.

Table summarising identified (viable) receptors				
Principle Receptor	Detail	Viable and critical receptors		
		Viability	Justification	Critical receptor
Humans	Users of the current site	Yes	Grazing land	Adult
	End user of the developed site	Yes	Children present	Child
	Construction operatives and other site investigators	Yes		Adult
Vegetation	Current site	Yes	Trees on site	Vegetation
	Developed site	Yes	Trees to remain	Vegetation
Controlled waters	Surface waters (Rivers, streams, ponds and above ground reservoirs)	Yes	Higgin Brook onsite	Surface waters
	Ground waters (used for abstraction or feeding rivers / streams etc.)	No	Devensian Till onsite	Groundwater
	Building materials	Yes	Assessed in report Section 10	Building materials

Table 8.3.5

## 8.4 Identification of pathways

### 8.4.1 Pathways to human receptors

8.4.1.1 Guidance published by the Environment Agency in Science Report SC050021/SR3 'Updated technical background to the CLEA model' provides a detailed assessment of pathways and assessment and human exposure rates to source contaminants. In summary, there are three principal pathway groups for a human receptor:

Table summarising likely pathways	
Principal pathways	Detail
Ingestion through the mouth	Ingestion of air-borne dusts
	Ingestion of soil
	Ingestion of soil attached to vegetables
Inhalation through the nose and mouth.	Ingestion of home grown vegetables
	Inhalation of air-borne dusts
	Inhalation of vapours
Absorption through the skin.	Dermal contact with dust
	Dermal contact with soil

Table 8.4.1

8.4.1.2 The site currently comprises open fields surfaced in grass and used for grazing livestock. It is understood that this has been the principal site use for much of the sites history, if not all. Based on such we have considered all the above pathways would be present for current users with the exception of those associated with vegetables.

8.4.1.3 Following redevelopment the site will be occupied by housing with associated gardens and landscaping. Based on such all of the above pathways will be considered for proposed site users. A summary of our pathway assessment is presented in Section 8.4.4.

#### 8.4.2 Pathways to vegetation

8.4.2.1 Guidance published by the Environment Agency in Science Report SC050021/SR (Evaluation of models for predicting plant uptake of chemicals from soil) provides a detailed assessment of plant uptake pathways. In summary, plants are exposed to contaminants in soils by the following pathways:

- Passive and active uptake by roots.
- Gaseous and particulate deposition to above ground shoots.
- Direct contact between soils and plant tissue.

8.4.2.2 All of the above routes of exposure are considered to be present for vegetation.

#### 8.4.3 Pathways to controlled waters

8.4.3.1 A number of pathways exist for the transport of soil contamination to controlled waters. A summary of these pathways is presented below:

- Percolation of water through contaminated soils
- Near-surface water run-off through contaminated soils
- Saturation of contaminated soils by flood waters

8.4.3.2 Near surface soils comprise cohesive Devensian Till deposits which are considered impermeable and extend to depths beyond 4.7m at the site. The clay soils will severely restrict the percolation of surface water into the underlying aquifer of the Bowland Shale Formation, therefore, pathways associated with percolation of surface water will not be considered further.

8.4.3.3 Based on the permeability of near surface Devensian Till deposits, in our opinion such soils are considered amenable to promoting significant amounts of near surface water run off through contaminated soils. Such pathways will therefore be considered further.

8.4.3.4 The site is not recorded within a fluvial flood plain and as such saturation of contaminated soils by flood waters is unlikely to occur.

#### 8.4.4 Summary of identified likely pathways

8.4.4.1 Based on the above assessments, the following table summarises likely pathways of potential chemical contaminants at the site to identified receptors.

Table of likely pathways		
Receptor group	Critical receptor	Pathway
Proposed site users	Child	Ingestion of air-borne dusts
		Ingestion of soil
		Ingestion of soil attached to vegetables
		Ingestion of home grown vegetables
		Inhalation air-borne dusts
		Inhalation of vapours
		Dermal contact with dust
		Dermal contact with soil
Current site users and construction operatives	Adult	Ingestion of air-borne dusts
		Ingestion of soil
		Inhalation of air-borne dusts
		Inhalation of vapours
		Dermal contact with dust
		Dermal contact with soil
Vegetation		Root uptake, deposition to shoots and foliage contact
Groundwater	Surface water	Near-surface water run-off through contaminated soils

Table 8.4.4

## 8.5 Assessment of sources of chemical contamination

### 8.5.1 Introduction

8.5.1.1 Initially, potential sources of contamination are assessed using the following elements of the investigation process.

- History of the site
- Desk study information
- Site reconnaissance
- Geology
- Fieldwork

These elements will dictate a relevant soil/water testing regime to quantify possible risks of any identified contaminative sources which may harm identified receptors.

### 8.5.2 Source assessment – History of the site

8.5.2.1 The history of the site and its immediate surroundings based on published Ordnance Survey maps is described in Section 3.

**8.5.2.2** Based on published historical maps, there is no evidence to indicate the site has been subject to activities which could produce a source of chemical contamination; however, records indicate that an iron and brass foundry was recorded beyond Chipping Lane to the west, in addition to a small gas works, mill, unclassified works, dairy and a garage located nearby to the south-east and south-west. Some of these land uses are included in 'Industry profiles' published by the Department of the Environment, which provides an indication of the type of chemical contaminants likely to be used by the industry. Clearly, the possibility of potential soil contamination from this former land use would be dependent upon the management of the potential contaminants within this former industry. At this stage we have assumed there is a risk of associated contaminants impacting soils at the site, and thus there is a potential (and thus a risk) of this chemical source to migrate to the subject site and harm on site receptors.

### **8.5.3 Source assessment – Desk study information**

**8.5.3.1** Envirocheck presents a detailed database of environmental information in relation to the site including;

- Pollution incidents
- Landfill sites
- Trading activities

#### **8.5.3.2** *Pollution incidents*

**8.5.3.2.1** Envirocheck report a number of pollution incidents to controlled waters within 2000m of the site, the closest of which are recorded onsite and 80m to the south. The onsite incidents are dated June 1997 and are associated with the release of paint/dyes and inert suspended solids into Higgin Brook, classified as Category 3 minor incidents. Given the type and severity of the incidents they are considered unlikely to have impacted the site. Furthermore, two incidents are also recorded offsite immediately adjacent to the south and south-west, associated with the release of light oils and waste milk again into Higgin Brook, classified as Category 3 minor and Category 2 significant incidents respectively. Again, given the type and severity of such incidents they considered unlikely to have impacted the subject site.

#### **8.5.3.3** *Landfill sites*

**8.5.3.3.1** Envirocheck reports there are two registered landfill sites within 1km of the site. One is located approximately 750m to the east, which indicates the site was in receipt of inert, non-hazardous and industrial wastes. The second is recorded 960m to the south of the site, with records indicateing the site is now dormant and was in receipt of demolition material and uncontaminated soils.

**8.5.3.3.2** In addition, we have reviewed old Ordnance Survey maps and there is no obvious evidence of significant quarrying in the area, other than a small number of BGS mineral sites, recorded between 400m and 850m of the subject site and exploited the underlying clays and grits.



**8.5.3.3.3** Based on the above, due to the distance, the risk of any chemical contamination associated with landfill sites and restored mineral sites in the area, migrating and impacting identified receptors at the site, is considered low.

**8.5.3.4** *Trading activities*

**8.5.3.4.1** Envirocheck reports the closest active trade entry is located 19m to the south of the site, associated with a garage (Irelands Ltd). It should also be noted that the site is recorded as a fuel station entry, however, records indicate this is now obsolete. Such activities utilise chemicals which could harm identified receptors and at this stage are considered a risk of impacting the subject site.

**8.5.4** **Source assessment – Site reconnaissance**

**8.5.4.1** A full description of the site and observed adjacent land uses is provided in Section 3 of this report. A plan summarising observations made on site during our site reconnaissance visit is presented on Drawing 02b.

**8.5.4.2** We did not observe any obvious evidence of any current or recent activities on site which provide a potential source of chemical contamination. We did observe the garage as noted in paragraph 8.5.3.4.1 adjacent to the south, which could provide a source of contamination worthy of further consideration.

**8.5.5** **Source assessment – Geology**

**8.5.5.1** The geological map of the area indicates the topography local to the site is formed in deposits of Devensian Till and Bowland Shale Formation. Typically, and in our experience, such deposits do not exhibit any abnormal concentrations of naturally occurring chemical contaminants.

**8.5.6** **Source assessment - Fieldwork observations**

**8.5.5.1** None of the exploratory excavations exposed soils or water, which provides visual or olfactory evidence, which would indicate the soils on site are chemically contaminated.

## 8.5.7 Source assessment - summary

8.5.7.1 Based on the paragraphs above, we have identified the following potential sources of contamination:

Table summarising results of source assessment				
Source	Origin of information	Possible contaminant	Probability of risk occurring	Likeiy extent of contamination
<b>On site</b>				
N/A	N/A	N/A	N/A	N/A
<b>Adjacent sites</b>				
Garage	Historical maps, site reconnaissance	TPHs, PAHs, VOCs/SVOCs	Possible	Southern part of the site
Small gas works	Historical maps	Metals, TPHs, PAHs, VOCs/SVOCs	Possible	
Mill	Historical maps	Metals, TPHs, PAHs, VOCs/SVOCs	Low likelihood	
Unclassified works	Historical maps	Metals, TPHs, PAHs, VOCs/SVOCs	Possible	
Dairy	Historical maps	Organic contaminants	Low likelihood	
Iron and brass foundry	Historical maps	Metals, TPHs	Low likelihood	Western part of site
Table reference 8.5.7				

## 8.6 Initial Conceptual Model

8.6.1 Based on our assessment of potential contaminative sources, identified receptors and viable pathways to receptors described in preceding paragraphs, we have produced an initial conceptual model in the form of a table which is presented in Appendix I.

8.6.2 Based on the conceptual model there are risks which exceed the low category which in our opinion are unacceptable, and require either remedial action or further investigation by laboratory testing of soil/water samples to refine the risk assessment.

## 8.7 Laboratory testing

### 8.7.1 Testing regime – Human receptors

8.7.1.1 Based on our source assessment (and our initial conceptual model) we have no evidence to identify any past or recent uses of the site which may have generated specific contamination. However, uses on neighbouring sites have been identified which may have the potential to generate specific contamination which could migrate to the subject site. Three samples, targeting areas considered to be at risk of potential contaminative sources were scheduled to measure concentration of Total Petroleum Hydrocarbons (TPH), in addition to BTEX and MTBE, VOCs and SVOCs. Such samples were taken from exploratory excavations local to site boundaries where potential contaminants could have the potential to migrate onto site.

8.7.1.2 In addition, sixteen samples of near surface Topsoil were submitted for measurement of organic and inorganic contaminants. The results of laboratory determination of concentration of chemical contaminants are presented in Appendix G.

8.7.1.3 The following table summarises the scheduled testing, in relation to soil types and identified receptors under consideration of the conceptual model.

**Table summarising scheduled testing (human receptors)**

Sample origin	Sample type	Strata	Targeted sampling	Non targeted sampling	Scheduled testing	Critical receptor
DTS02 0.1m	Soil	Topsoil			Inorganic & organics	All human receptors
DTS03 0.1m						
DTS04 0.1m						
DTS05 0.1m						
DTS07 0.1m						
TP01 0.1m						
TP04 0.1m						
TP05 0.1m						
TP06 0.1m			✓			
TP07 0.1m						
TP09 0.1m						
TP13 0.1m						
TP15 0.2m						
TP17 0.1m						
TP18 0.1m						
TP20 0.1m						
TP06 0.5m	Soil	Devensian Till			TPH, VOCs and SVOCs	
TP10 1.0m			✓			
TP15 2.3m						

**Table 8.7.1.3**

## 8.7.2 Testing regime – Water receptors

8.7.2.1 Whilst we have identified a number of potential offsite sources of chemical contamination, at this point in time we have not scheduled testing to measure the leachable concentrations of those contaminants as outlined in paragraph 8.7.1.1 above. Following assessment, if total concentrations of such contaminants are measured and are deemed to present a risk to controlled waters then further leachate assessment of such contaminants may then be recommended. In order to produce a quantitative assessment, however, we have selected four samples of Topsoil for the measurement of commonly occurring leachable inorganic and organic contaminants where they are considered a risk to water resources. This in our opinion is an absolute minimum to assist in the risk assessment. Further laboratory testing would increase the accuracy of the risk assessment.

8.7.2.2 The following table summarises the scheduled testing, in relation to soil types and identified receptors under consideration of the conceptual model.

Sample origin	Sample type	Strata	Targeted sampling	Non targeted sampling	Scheduled testing	Critical receptor
TP03 0.1m	Soil	Topsoil		✓	Inorganic & organics	Surface waters
TP08 0.1m						
TP11 0.1m						
TP16 0.1m						

Table 8.7.2.2

### 8.7.3 Criteria for assessment of test data – Human receptors

8.7.3.1 Assessment of laboratory test data has been carried out with reference to current nationally recognised documents listed in the final page of Appendix B. Due to changes in guidance on contaminated land, items 6-8 and item 10 in the document listing above have been withdrawn. In the absence of alternative guidance however we have used these documents. Where new guidance is available, this has been followed in preference to superseded guidance.

8.7.3.2 Suitable 4 Use Levels (S4ULs) are used as a screening tool to assess the risks posed to health of humans from exposure to soil contamination in relation to land uses. Where published S4ULs are not available, we have adopted Category 4 Screening Levels (C4SLs) where appropriate, derived by DEFRA, and Soil Screening Values (SSV) derived by Soiltechnics and by Atkins (SSV<sup>ATK</sup>). The S4ULs have been derived by Land Quality Management (LQM) and the Chartered Institute of Environmental Health (CIEH) and presented in 'The LQM/CIEH S4ULs for Human Health Risk Assessment'. They are derived in accordance with UK legislation, national as well as Environment Agency (EA) Policy using a modified version of the EA CLEA model and other available guidance. The S4ULs have been prepared for a number of metals and polycyclic aromatic hydrocarbons (PAH) and are used in preference to C4SLs and values produced by Soiltechnics and Atkins. The CLEA model has been used with toxicology data presented by the EA, LQM/CIEH and Atkins (in that order of preference) to derive SSVs by Soiltechnics. SSVs produced by Atkins are presented on their ATRISK<sup>SOIL</sup> website.

8.7.3.3 S4ULs, C4SLs, SSVs and SSV<sup>ATK</sup>s represent 'intervention values'; indications to an assessor that soil concentrations above these levels might present an unacceptable risk to the health of site users. These soil guideline values have been produced using conceptual exposure models, which use assumptions and are applied to differing end uses of land. If the values are exceeded, it does not necessarily imply there is an actual risk to health and site-specific circumstances should be taken into account. Conversely, where a critical pathway or chemical form of the contaminant has not been evaluated, a risk may be present even if the guideline has not been exceeded.

- 8.7.3.4 For evaluation of test data in relation to polycyclic aromatic hydrocarbon (PAH) contamination, we have compared measured concentrations with corresponding S4ULs. The S4ULs for PAHs are dependent on the Soil Organic Matter (SOM) content of the soils.
- 8.7.3.5 For evaluation of total petroleum hydrocarbon (TPH), BTEX and VOC/SVOC related contamination we have compared measured concentrations directly to the relevant S4ULs where available.
- 8.7.3.6 We have followed procedures outlined by the CIEH to compare measured concentrations of metals and PAH contaminants against guideline values. TPH, SVOC and VOC related contaminants are compared directly with the relevant guideline values. The guidance presents an approach to data analysis and includes the examination of data for potential outliers, assessment of the normality of the test data and the calculation of a 95% Upper Confidence Limit (UCL). The UCL provides an estimate of the population mean, based on test data, with a 95% confidence that the actual mean does not exceed this value. The UCL is compared to the guideline value for the site.
- 8.7.3.7 We have adopted a conservative approach for current site users and compared measured concentrations of contaminants against guideline values for residential without plant uptake land use. For end users we have compared measured test data against guideline values presented for residential with plant uptake land use.
- 8.7.4 Criteria for assessment of test data – Construction operatives**
- 8.7.4.1 In the absence of guidelines we have adopted commercial/industrial guideline values for assessment of construction operatives.
- 8.7.5 Criteria for assessment of test data – Vegetation**
- 8.7.5.1 Guidance published by Forest Research in "*BPG Note 5 - Best Practice Guidance for Land Regeneration*" suggests that a residential without plant uptake or industrial/commercial CLEA model should be adopted for this receptor although specific guideline values are provided for copper and zinc at 130mg/kg and 300mg/kg respectively. As a practice we have adopted the industrial / commercial CLEA model for assessment of test data for vegetation.
- 8.7.5.2 It is difficult to quantify the phytotoxicity of a contaminant as large variations exist between plant tolerances, soil effects and synergistic/antagonistic reactions between chemicals. Due to the complexities of the effects of soil contamination on different plant species, we recommend that the test results presented in this report are passed to a landscape architect for the selection of suitable planting.

**8.7.6 Criteria for assessment of test data – Controlled waters**

8.7.6.1 For interpretation of test data in relation to water receptors we have directly compared measured values with the Environmental Quality Standards (EQS) and UK Drinking Water Standards (UKDWS). In the absence of EQS or UKDWS we have adopted World Health Organisation Drinking Water Guidelines (WHODWG)

8.7.6.2 EQS values are published by the Environment Agency in their publication, "Environment Agency technical advice to third parties on Pollution of Controlled Waters for Part 11A of the Environmental Protection Act 1990". EQS values for most inorganic contaminants in freshwater are dictated by the hardness of the receiving watercourse. The hardness of water is a measure of the concentration of calcium carbonate in the water. Although we have not sampled water from nearby watercourses, we have reviewed information supplied by the Drinking Water Inspectorate website, which indicates a hardness of <100mg/l for drinking water in the local area. Although not an insitu groundwater measurement, such results are likely to be similar to those that would be measured in groundwater in the local area.

8.7.6.3 Using this information for List II substances (DOE Circular 7/89) we have compared the measured values with the EQS values relative to the hardness of the receiving watercourse assuming a worst case scenario of the watercourse supporting 'sensitive' aquatic life.

8.7.6.4 UKDWS are presented in the Water Supply (Water Quality) Regulations. We have adopted EQS values in preference to alternative guidelines where possible.

**8.7.7 Evaluation of test data – Human receptors**

8.7.7.1 Tables summarising and analysing test data are presented in Appendix H. The following table summarises the outcome of the analyses.

<b>Table Summarising assessment of test data for Human receptors</b>					
<b>Analysis tables</b>	<b>Receptor group</b>	<b>Critical receptor</b>	<b>CLEA model</b>	<b>Inorganic contaminants</b>	<b>Organic contaminants</b>
1 and 5	Current site users	Adult	Residential without plant uptake	No exceedances	No exceedances
2 and 6	Future site users	Child	Residential with plant uptake	No exceedances	No exceedances
3 and 7	Construction operatives	Adult	Industrial / commercial	No exceedances	No exceedances

Table 8.7.7.1

8.7.7.2 Based on the above, laboratory testing has not identified any measured concentrations of commonly occurring inorganic and organic contaminants which exceed current guideline values for human receptors. It should also be noted that all measured concentrations of TPHs, VOCs and SVOCs have been recorded below detectable limits.

### **8.7.8 Evaluation of test data – Vegetation**

**8.7.8.1** Comparison of test data with guideline values is presented on Tables 4 and 7 in Appendix H. None of the measured concentrations exceed the adopted guideline values. On this basis, we are of the opinion that measured concentrations are unlikely to exhibit significant contamination with respect to vegetation.

**8.7.8.2** It is difficult to quantify the phytotoxicity of a contaminant as large variations exist between plant tolerances, soil effects and synergistic/antagonistic reactions between chemicals. Due to the complexities of the effects of soil contamination on different plant species, we recommend that the test results presented in this report are passed to a landscape architect for the selection of suitable planting.

### **8.7.9 Evaluation of test data – Controlled waters**

#### **8.7.9.1 *Inorganic contaminants***

**8.7.9.1.1** The measured values of inorganic contaminants fall well below relevant guideline values with the exception of copper. Out of the 4 samples of Topsoil tested across the site, 3 exceed the EQS value of 6µg/l, measured at concentrations of 12µg/l, 14µg/l and 18µg/l.

#### **8.7.9.2 *Organic contaminants (polycyclic aromatic hydrocarbons)***

**8.7.9.2.1** For the analysis of PAH contamination, the sum of the following contaminants has been compared to a UKDWS.

- Benzo(b)fluoranthene
- Benzo(k)fluoranthene
- Benzo(ghi)perylene
- Indeno(1,2,3-cd)pyrene

**8.7.9.2.2** The summed concentration of the PAH 'suite' for each samples do not exceed the UKDWS. In addition the leachable concentration of benzo(a)pyrene and naphthalene do not exceed their respective guideline values.

## **8.8 Updated conceptual model**

### **8.8.1 Human receptors**

**8.8.1.1** Based on the above, laboratory testing has not identified any measured concentrations of chemical contaminants which exceed current guideline values for identified human receptors. Based on the above evaluation, the concentrations of contaminants measured on soil samples taken from the site are considered unlikely to exhibit significant contamination from a perspective of human receptors.

## 8.8.2 Water receptors

8.8.2.1 Laboratory testing has identified elevated concentrations of leachable copper in 2 out of 4 samples of Topsoil tested across the site. Given the limited historic use of the site (fields from earliest historical maps until present) it is most likely to be attributed to the use of copper based fertilisers in agriculture. However, if this is the source total concentrations of copper would also be expected to be present to some extent in Topsoil across the site and certainly at higher concentrations than those measured to date. The underlying naturally deposited Devensian Till has not been noted to contain gravels which could provide a potential source of copper.

8.8.2.2 The EQS values used in the assessment are largely dictated by the hardness of the receiving watercourse and we have been fairly conservative with the hardness value adopted for the site based on readily available groundwater data. It is likely that if water was tested within Higgin Brook onsite that hardness values would be higher than those adopted (>200mg/l rather than <100mg/l) which would have the effect of increasing the EQS value of copper from 6µg/l to 28µg/l. If this were to be the case then the concentrations of leachable copper measured in Topsoil deposits would fall below the guideline value for the site.

8.8.2.3 Based on the above, we are of the opinion that the concentrations of leachable copper recorded in Topsoil at the site are unlikely to have an adverse effect on surface waters in the area. However, as a precaution we recommend that surface waters within Higgin Brook are tested to determine site specific values of hardness which will enable a more detailed risk assessment to be completed.

## 8.8.3 Summary

8.8.3.1 Having now completed analysis of laboratory testing, we can now update our conceptual model which is presented in Appendix H.

8.8.3.2 Based on the updated conceptual model, with the exception of determining hardness values of surface waters in Higgin Brook, none of the assessed risks exceed the low category and on this basis remedial action is not considered necessary at this stage to render the site fit for purpose. Sources that have not been identified by laboratory testing have been removed from the conceptual model.

## 8.9 Actions

8.9.1 Based on the above our sole recommendations are as follows:-

- Hardness values within surface waters of Higgin Brook are determined to enable a more detailed risk assessment to be completed in relation to water receptors
- Construction operatives adopt adequate hygiene precautions



## **8.10 Risk assessment summary and recommendations**

**8.10.1** Based on our assessments described above, we can provide the following summary and recommendations for each identified receptor.

### **8.10.2 Current and proposed site users**

**8.10.2.1** As no source of significant chemical contamination has been identified on site, we are of the opinion that the site represents a very low risk of causing harm to the health of identified current users of the site.

### **8.10.3 Construction operatives and other site investigators**

**8.10.3.1** The risk of damage to health of construction operatives and other site investigators is, in our opinion, low. As a precautionary approach, however, we recommend adequate hygiene precautions are adopted on site. Such precautions would be:-

- Wearing protective clothing particularly gloves to minimise ingestion from soil contaminated hands.
- Avoiding dust by dampening the soils during the works.
- Wearing masks if processing produce dust.

**8.10.3.2** Guidance on safe working practices can be obtained from the following documents

- The Health and Safety Executive Publication "*Protection of Workers and the General Public during the Development of Contaminated Land*" (HMSO) and
- "*A Guide to Safer Working on Contaminated Sites*" (CIRIA Report 132).

**8.10.3.3** In addition, reference should be made to the Health and Safety Executive. In all cases work shall be undertaken following the requirements of the Health and Safety at Work Act 1974 and regulations made under the Act including the COSHH regulations.

### **8.10.4 Controlled waters**

**8.10.4.1** Based on the risk assessment outlined in Section 8.8.2 above, we are of the opinion that the site currently represents a low-moderate risk of causing harm to water receptors, and as a precaution we recommend that values of hardness are determined in surface waters of Higgin Brook to enable a more detailed risk assessment to be undertaken.

### **8.10.5 Vegetation**

**8.10.5.1** As no source of significant chemical contamination has been identified on site, we are of the opinion that the site represents a low risk of causing harm to vegetation.

## **8.11 Statement with respect to National Planning Policy Framework**

**8.11.1** Based on investigations completed to date with respect to chemical contamination, we are of the opinion the proposed development will be safe and suitable for use for the purpose for which it is intended (without the need for any remedial action) thus meeting the requirements of the National Planning Policy Framework section 121, and compliant with the Building Regulations Part C, '*Site preparation and resistance to contaminants and moisture*'.

## **8.12 On Site Monitoring**

**8.12.1** We have attempted to identify the potential for chemical contamination on the site, however, areas, which have not been investigated at this stage, may exhibit higher levels of contamination. If such areas are exposed at any time during construction we will be pleased to re-attend site to assess what action is required to allow the development of safely proceed.

## 9 Gaseous contamination

9.1	Legislative framework
9.2	General
9.3	Assessment of source of gases
9.4	Conclusion
9.5	Statement with respect to National Planning Policy Framework

### 9.1 Legislative framework

9.1.1 There is currently a complex mix of documentation relating to legislative and regulatory procedures on the issue of contamination and it is not considered a purpose of this report to discuss the detail of these regulations. Essentially, Government Policy is based on *'suitable for use approach'*, which is relevant to both the current and proposed future use of land. For current use Part IIA of the Environmental Protection Act 1990 provides the regulatory regime (see Section 8.1 above). The presence of harmful soil gases could provide a 'source' in a 'pollutant linkage' allowing the regulator (Local Authority) to determine if there is a significant possibility of harm being caused to humans, buildings or the environment. Under such circumstances the regulator would determine the land as 'contaminated' under the provision of the Act requiring the remediation process to be implemented with the Environment Agency responsible for enforcement.

9.1.2 The Town and Country Planning (General Development Procedure) Order 1995, requires the planning authority to consult with the Environment Agency before granting planning permission for development on land within 250 metres of land which is being used for deposit of waste, (or has been at any time in the last 30 years) or has been notified to the planning authority for the purposes of that provision.

9.1.3 Building control bodies enforce compliance with the Building Regulations. Practical guidance is provided in Approved documents, one of which is Part C, *'Site preparation and resistance to contaminants and moisture'* which seeks to protect the health, safety and welfare of people in and around buildings and includes requirements for protection against harm from soil gas.

### 9.2 General

9.2.1 The following assessment relates to the potential for, and the effects of, gases generated by biodegradable matter. The potential for the development to be affected by radon gas is considered in Section 3 above. The principal ground gases are carbon dioxide (CO<sub>2</sub>) and methane (CH<sub>4</sub>). The following table provides a summary of the effects of these gases when mixed with air.

---

**Significant gas concentrations in air**

---

Gas	Concentration by volume	Consequence
Methane	0.25%	Ventilation required in confined spaces
	5 - 15%	Potentially explosive when mixed with air
	30%	Asphyxiation
	75%	Death after 10 minutes
Carbon Dioxide	0.5%	8 hour long term exposure limit (LTEL) (HSE workplace limit)
	1.5%	15 min short term exposure limit (STEL) (HSE workplace limit)
	>3%	Breathing difficulties
	6 - 11%	Visual distortion, headaches, loss of consciousness, possible death
	>22%	Death likely to occur

---

**Table 9.2.1**

9.2.2

Following the current Building Regulations Approved Document C1, Section 2 'Resistance to Contaminants' (2004 incorporating 2010 and 2013 amendments) a risk assessment approach is required in relation to gaseous contamination based on the source-pathway-receptor conceptual model procedure. We have adopted procedures described in the following reference documents for investigation and assessments of risk of the development being affected by landfill type gases (permanent gases) and if appropriate the identification of mitigation measures.

- BS10175:2011 'Investigation of potentially contaminated sites- Code of Practice'
- BS8576:2013 'Guidance on investigations for ground gas – Permanent gases and Volatile Organic Compounds (VOCs)'
- BS8485:2015 'Code of practice for the design of protective measures for methane and carbon dioxide ground gases for new buildings'
- CIRIA Report C665 'Assessing risks posed by hazardous ground gases to buildings' (2007)
- NHBC report No 10627-R01(04) 'Guidance on development proposals on sites where methane and carbon dioxide are present' (January 2007)
- CL:AIRE Research Bulletin RB17 'A pragmatic approach to ground gas risk assessment' (November 2012)

Whilst we have followed the guidance and recommendations of BS8576, we have used BS8485:2015 to derive recommendations for protective works, and where considered necessary supplemented by NHBC report No 10627-R01(04).

9.2.3

An assessment of the risk of the site being affected by ground gases is based on the following aspects:

- a) Source of the gas
- b) Investigation information
- c) Migration feasibility
- d) Sensitivity of the development and its location relative to the source

### 9.3 Assessment of source of gases

#### 9.3.1 General sources

9.3.1.1 The following table summarises the common sources of ground gases and parameters affecting the generation of ground gases:

Source and control of gases	
Type	Parameters affecting the rate of gassing
Landfills	Portion of biodegradable material, rate reduces with time
Mineworkings	Flooding reduces rate of gassing
Dock silt	Portion of organic matter
Carbonate deposits	Ground / rainwater (acidic) reacts with some carbonates to produce carbon dioxide.
Made Ground	Thickness of Made Ground and proportion of degradable organic matter
Naturally deposited soils/rocks	Thickness of Made Ground and proportion of degradable organic matter

Table 9.3.1

The rate of decomposition in gas production is also related to atmospheric conditions, pH, temperature, and water content / infiltration.

9.3.1.2 As the site is not within a dockland environment or an area affected by mineworkings, and near surface soils do not exhibit high carbonate content, then potential gas sources are limited to landfills and/or soils with a high proportion of organic matter.

#### 9.3.2 Landfill and infilled ground sources

9.3.2.1 Waste Management Paper 27 (1991) produced by the Department of the Environment 'Control of Landfill Gases' contains the recommendation to avoid building within 50m of a landfill site actively producing large quantities of landfill type gases and to carry out site investigations within a zone 250m beyond the boundary of a landfill site. No distinction is made between sites of differing ground conditions, but the paper does not advocate the site is safe beyond the 250m zone, dependant, of course, upon the type of landfill and potential for migration of landfill gases.

9.3.2.2 Within a 2km radius of the site, there are no BGS recorded or historical landfill sites; however, there are two registered landfill sites. Lords Delph (Forty Acre Lane, Longridge) is located approximately 750m to the east of the site and has been accepting non-biodegradable waste since at least 1982. Chapel Hill Quarry is located approximately 960m to the south of the site and accepted non-biodegradable waste; in 1992, the site was recorded as dormant.

9.3.2.3 In addition, we have reviewed old Ordnance Survey maps and there is no obvious evidence of significant quarrying in the area, other than a small number of BGS mineral sites, recorded between 400m and 850m of the subject site which exploited the underlying clays and grits. The geological map of the area indicates areas of infilled ground which approximately coincide with such areas.

9.3.2.2 Due to the distance of the sites from the subject site, in our opinion they are considered very unlikely to represent a potential source of ground gases which could affect the subject site. Furthermore, a series of small ponds are noted to have been recorded historically within fields surrounding the site and possibly filled in recent years. However, given the limited size of the water features it is considered unlikely that any gases associated with organic/putrescible material contained within would have the potential to affect the site.

**9.3.3 Soil conditions**

9.3.3.1 None of the soils observed in exploratory excavations, in our opinion, exhibit significant concentrations of organic matter which are likely to produce elevated quantities of carbon dioxide and / or methane gas.

9.3.3.2 Based on an assessment of 'deep' geological conditions we are of the opinion that it is unlikely that the subject site would be affected by significant quantities of carbon dioxide and methane generated by soils/rocks at depth.

9.3.3.3 Based on the presence of extensive deposits of cohesive and impermeable Devensian Till in the local area, any potential migration of landfill type gases which may be generated at the sources outlined in Section 9.3.2 would also be severely restricted and unlikely to feasibly migrate to the subject site. We can confirm that we have consulted with Ribbles Valley Borough Council with regards to this matter and they have agreed with such assessments. A copy of their correspondence is presented in Appendix K.

**9.3.4 Source assessment summary**

9.3.4.1 The following table summarises the possibility of a source of landfill type gases.

<b>Source assessment summary</b>		
<b>Potential source origin</b>	<b>Viability of source</b>	<b>Evidence</b>
Landfills	Unlikely	Desk study information
Mineworkings	Unlikely	Desk Study information Geological conditions not amenable
Dock silt	Unlikely	Site remote from dockland environment
Carbonate deposits	Unlikely	Recorded and observed soil conditions do not indicate high concentrations of carbonates
Made Ground	Unlikely	None present.
Naturally deposited soils/rocks	Unlikely	Soils exposed in exploratory excavations do not exhibit high concentrations of organic matter

**Table 9.3.4**

## **9.4 Conclusion**

**9.4.1** Based on the above there is no evidence to demonstrate that there is a potential source rendering the site at a significant risk of being affected by ground gases (carbon dioxide / methane) sufficient to cause significant harm to human end users of the site, construction operatives or indeed buildings. On this basis, it is not considered necessary to consider possible pathways for migration of ground gases, and indeed implementation of further investigations to measure concentrations of ground gases. Again on the basis of evidence provided above, mitigation measures against ingress of ground gases into the proposed development are not considered necessary.

## **9.5 Statement with respect to National Planning Policy Framework**

**9.5.1** Based on investigations completed to date with respect to gaseous contamination, we are of the opinion the proposed development will be safe and suitable for use for the purpose for which it is intended (without the need for any remedial action) thus meeting the requirements of the National Planning Policy Framework section 121, and compliant with the Building Regulations Part C, '*Site preparation and resistance to contaminants and moisture*'.

## 10

# Effects of ground conditions on building materials

---

10.1	General
10.2	Reference documents
10.3	Hazard identification and assessment
10.4	Provision of test data to specifiers/manufacturers/installers
10.5	Risk assessments for individual building materials
10.6	Concrete – general mechanisms of attack
10.7	Concrete – sulphate attack
10.8	Concrete – chloride attack
10.9	Concrete – acid attack
10.10	Concrete – magnesium attack
10.11	Concrete – ammonium attack
10.12	Concrete blocks
10.13	Clay bricks/pipes
10.14	Mortar
10.15	Metals – general
10.16	Metals – cast iron
10.17	Metals – steel piles
10.18	Metals – stainless steel
10.19	Metals – galvanised steel
10.20	Metals – copper
10.21	Metals – lead
10.22	Plastics – general
10.23	Plastic membranes and geotextiles
10.24	Plastic pipes
10.25	Electrical cables
10.26	Rubbers

---

### 10.1 General

10.1.1 Building materials are often subjected to aggressive environments which cause them to undergo chemical or physical changes. These changes may result in loss of strength or other properties that may put at risk their structure integrity or ability to perform to design requirements. Aggressive conditions include:-

- Severe climates
- Coastal conditions
- Polluted atmospheres
- Aggressive ground conditions

This report section only considers aggressive ground conditions, with other items considered outside our brief and scope of investigations.



**10.1.2** In aggressive ground conditions, the potential for contaminant attack depends on the following:-

- The presence of water as a carrier of chemical contaminants, (except free phase organic contamination)
- The availability of the contaminant in terms of solubility, concentration and replenishment rate
- Contact between the contaminant and the building material
- The nature of the building materials and its capability of being attacked by contaminants

In general the thicker the building material the less likelihood there is for contaminant attack to cause damage to the integrity of the structure.

## **10.2 Reference documents**

**10.2.1** Following the Environment Agency publication '*Model Procedures for the Management of Land Contamination*' (Contaminated Land Report 11) the following documents have been referred to in production of the following report paragraphs.

- '*Performance of Building Materials in Contaminated Land*' report BR255 (Building Research Establishment 1994).
- '*Risks of Contaminated Land to Buildings, Building Materials and Services. A Literature Review*' - Technical Report P331 (Environment Agency 2000).
- '*Guidance on assessing and managing risks to buildings from land contamination*' - Technical Report P5 035/TR/01).
- Building Regulations Approved document C - site preparation and resistance to contaminants and moisture (Office of the Deputy Prime Minister, 2004).
- '*Concrete in aggressive ground*' Special Digest 1: 2005 (Building Research Establishment).

## **10.3 Hazard identification and assessment**

**10.3.1** The identification of hazards is based on the findings of this investigation primarily relating to former land uses (potential for chemical contamination, and likely type of contamination) and laboratory determination of concentration of chemical contaminants. Clearly, the scope of laboratory testing is determined with respect to former land uses, contaminants which may cause harm to human health and water resources.

**10.3.2** Based on the above, the scope of our testing regime is described in Sections 8. We have utilised this test data in production of the following risk assessments in relation to building materials, in conjunction with test data targeting the effects of chemical attack on concrete in contact with the ground, as described in BRE Special Digest 1.

**10.3.3** The identification of hazards from contamination and subsequent assessment of risks is based on the following:-

- The contaminants present on site.
- The nature of the contaminant (i.e. calcium sulphate is much less soluble than sodium or magnesium sulphate and is, therefore, less of a concern with regards sulphate attack).
- The concentration of contaminants - in general the higher the concentration the greater the hazard.
- The solubility of the contaminants - contaminants which are not soluble will not generally react with materials.
- The permeability of the soils - i.e. ease by which fluids can transport contaminants to the building.

10.3.4 The process of risk assessment for building materials is concerned with identification of the hazard (contaminants at the site - a source) and subsequently how the contaminants can reach the building (pathway) and how they can react with the building (receptor). Thus the risk assessment is produced based on the source - pathway - receptor model.

## 10.4 Provision of test data to specifiers/manufacturer/installer

10.4.1 The following risk assessments are based on current published data. We strongly recommend, however, that information gained from this investigation are provided to specifiers/manufacturers/installers of building materials/service ducts/apparatus who may have more up to date research to confirm the ability of the product to resist the effects of chemical contaminants at the site for the desired lifespan of the product.

## 10.5 Risks assessments for individual building materials

10.5.1 The following/typical sections contain risk assessments for various building materials likely to be incorporated in developments. Other materials which we are not aware of may also be used in developments and in contact with the ground and, therefore, recommend the suppliers are consulted with respect to ground conditions at this site and their opinion sought as to the ability of the product to resist chemical conditions determined at the site.

## 10.6 Concrete - General mechanisms of attack

10.6.1 There are a number of mechanisms by which contaminants attack concrete including the following:-

- Hydrolysis of the hardened concrete.
- Degradation as a result of exchange reactions between calcium in calcium hydroxide (free lime hydrate) and ions in aggressive solutions.
- Expansive reactions as a result of chemical reaction or salt crystallisation.

## 10.7 Concrete - Sulphate attack

### 10.7.1 Hazard

10.7.1.1 Sulphate attack on concrete is characterised by expansion, leading to loss of strength, cracking, spalling and eventual disintegration. There are three principal forms of sulphate attack, as follows:-

- Formation of gypsum through reaction of calcium hydroxide and sulphate ions.
- Ettringite formation through reaction of tricalcium alluminate and sulphite ions.
- Thaumasite formation as a result of reactions between calcium silicate hydrates, carbonate ions (from aggregates) and sulphate ions.

### 10.7.2 Assessment

10.7.2.1 The hazard of sulphide attack is addressed by reference to procedures described in Building Research Establishment (BRE) Special Digest 1: 2005 '*Concrete in Aggressive Ground*' to establish a design sulphate class (DS) and the '*aggressive Chemical Environment for Concrete*' (ACEC). These procedures have been followed during our investigation and are described in the following paragraphs.

### 10.7.3 Desk Study Information

10.7.3.1 The first step in the procedure is to consider specific elements of the desk study. These are tabulated below.

Summary of desk study information			
Element	Interrogation	Outcome	SD1: 2005 reference
Geology	Likelihood of soils containing pyrites	Unlikely	Box C6
Past Industrial uses	Brownfield site?	No	C2.1.2

Table 10.7.3

10.7.3.2 A brownfield site is defined in SD1: 2005 as a site, or part of a site which has been subject to industrial development, storage of chemicals (including for agricultural use) or deposition of waste, and which may contain aggressive chemicals in residual surface materials, or in ground penetrated by leachates. Where the history of the site is not known, it should be treated as brownfield until there is evidence to classify it as natural.

10.7.3.3 Based on the above it is necessary to follow the procedures described in figure C4 ('*natural ground sites except where soils may contain pyrite*').

#### 10.7.4 Assessment of Design Sulphate Class

10.7.4.1 The sulphate concentration in a 2:1 water/soil extract was measured in eight samples of Devensian Till. The mean of the two highest test has been calculated as the characteristic value (refer to table 10.7.7).

#### 10.7.5 Assessment of groundwater mobility

10.7.5.1 With reference to SD1: 2005, Section C3.1, we are of the opinion that soils at the site generally have a low permeability and thus 'static' groundwater conditions are considered characteristic of the site.

#### 10.7.6 Assessment of pH

10.7.6.1 Following SD1: 2005, Section C5.1.1 (step 4) the characteristic value for pH within Devensian Till is 6.3, derived by taking the mean of the lowest 2 of the pH results.

#### 10.7.7 Assessment of aggressive chemical environment for concrete (ACEC)

10.7.7.1 Based on the design sulphate class, characteristic value of pH and assessment of groundwater mobility, and with reference to table C1 of SDI: 2005, the ACEC class for each soil type is presented in Table 10.7.2 below.

**Summary of concrete classification**

Soil type	No. of samples	Characteristic pH	Groundwater mobility	Characteristic sulphate (mg/l)	DS class	ACEC class
Devensian Till	8	6.3	Static	11.5	DS-1	AC-1s

**Table reference 10.7.7**

### 10.8 Concrete - Chloride attack

#### 10.8.1 Hazards

10.8.1.1 There are a number of ways in which chlorides can react with hydrated cement compounds in concrete. These are as follows:-

- Chlorides react with calcium hydroxide in the cement binder to form soluble calcium chloride. This reaction increases the permeability of the concrete reducing its durability.
- Calcium and magnesium chlorides can react with calcium aluminate hydrates to form chloroaluminates which result in low to medium expansion of the concrete.
- If concrete is subject to wetting and drying cycles caused by groundwater fluctuations, salt crystallisation can form in concrete pores. If pressure produced by crystal growth is greater than the tensile strength of the concrete, the concrete will crack and eventually disintegrate.

## **10.8.2 Risk assessment**

**10.8.2.1** Chlorides of sodium, potassium, and calcium are generally regarded as being non-aggressive towards mass concrete; indeed brine containers used in salt mines have been known to be serviceable after 20 years' service. Depending upon the type of concrete, and the cement used up to 0.4% chloride is allowed in BS8110: Part 1.

**10.8.2.2** In view of the past use of the site we consider the likelihood of elevated concentrations of chlorides in the ground is not likely to occur and on this basis have not specifically measured concentrations of chlorides and, in our opinion, the risk of buried concrete being affected by chlorides is considered low.

## **10.9 Concrete - Acid attack**

### **10.9.1 Hazards**

**10.9.1.1** Concrete being an alkaline material is vulnerable to attack by acids. Prolonged exposure of concrete structures to acidic solutions can result in complete disintegration.

### **10.9.2 Risk assessment**

**10.9.2.1** The rate of acid attack on concrete depends upon the following:-

- The type of acid
- The acid concentration (pH)
- The composition of the concrete (cement/aggregate)
- The soil permeability
- Groundwater movement

British Standard BS8110: Part 1 classifies extreme environment as one where concrete is exposed to flowing groundwater that has a pH<4.5. The standard also warns that Portland Cement is not suitable for acidic conditions with a pH of 5.5 or lower.

**10.9.2.2** The pH of the soil/groundwater was measured exceeding 5.5 and on this basis the risk of concrete being affected by acidic conditions is considered low.

## **10.10 Concrete - Magnesium attack**

### **10.10.1 Hazards**

**10.10.1.1** Magnesium salts (excepting magnesium hydrogen carbonate) are destructive to concrete. Corrosion of concrete occurs from cation exchange reactions where calcium in the cement paste hydrates and is replaced with magnesium. The cement loses binding power and eventually the concrete disintegrates.

## **10.10.2 Risk assessment**

- 10.10.2.1** In practise 'high' concentrations of magnesium will be found in the UK only in ground having industrial residues. Following BRE Special Digest 1:2005, measurement of the concentration of magnesium is recommended if sulphate concentrations in water extract or groundwater exceed 3000mg/l. Once measured the concentration of magnesium is considered further in BRE Special Digest in establishing the concrete mix to resist chemical attack.
- 10.10.2.2** We are not aware the site has been subject to any manufacturing processes which would have included magnesium containing compounds, and in addition sulphate concentrations did not exceed 3000mg/l, on this basis we have not measured the concentration of magnesium in soils at the site, and would consider the risk of soils at the site promoting attack on concrete is considered low.
- 10.10.2.3** BS EN 206-1:2000 '*Concrete - Part 1: Specification, performance, production and conformity*' does, however, provide exposure classes for concrete in contact with water, with varying concentrations of magnesium for the design/specification for concrete mixes. No groundwater was encountered by the investigation and we would consider the risk of magnesium requiring special consideration with respect to enhancement of exposure class for this contaminant in isolation to be low.

## **10.11 Concrete - Ammonium attack**

### **10.11.1 Hazards**

- 10.11.1.1** Ammonium salts, like magnesium salts act as weak acids and attack hardened concrete paste resulting in softening and gradual decrease in strength of the concrete.

### **10.11.2 Risk assessment**

- 10.11.2.1** UK guidance is not available on the concentration of ammonium which may affect concrete. BS EN 206-1: 2000 '*Concrete - Part 1: Specification, performance, production and conformity*' does, however, provide exposure classes for concrete in contact with water with varying concentrations of ammonia for the design/specification for concrete mixes.
- 10.11.2.2** As no groundwater was encountered by the investigation, we have not been able to obtain water samples for measurement of concentration of ammonia. In addition the site has no history which provides evidence of the uses of ammonia on site, and in overall conclusion the risk of concrete being affected by ammonia is considered low.

## **10.12 Concrete blocks**

### **10.12.1 Hazards**

10.12.1.1 Precast aggregate concrete blocks and autoclaved aerated concrete blocks are commonly used in the construction of shallow foundations. Concrete blocks are potentially attacked by the same contaminants and ground conditions which affect dense concrete.

### **10.12.2 Risk Assessment**

10.12.2.1 In general, the mechanism of attack on concrete blocks is the same for hardened concrete. We recommend parameters for ground conditions for concrete described in the preceding paragraphs for concrete blockwork in contact with the ground/groundwater and the blockwork manufacturers confirmation sought for applicability of their product.

## **10.13 Clay Bricks/Pipes**

10.13.1 Clay Bricks are highly durable materials which have been used in buildings for many centuries. Fire clay pipe material can also be considered similarly resistant to contaminants.

### **10.13.2 Hazards**

10.13.2.1 Dissolution of clay brick in a potentially serious cause of deterioration. The extent of dissolution depends upon the solubility of the glassy material (produced by firing of the clay) contained in the brick. The acidic nature of the glass phase will produce low solubility in a neutral and acidic environment, but can be soluble in a basic environment.

10.13.2.2 A potentially more serious hazard for brickwork is the crystallisation of soluble salts within the brick pore structure. Salts are transported by water to the interior of the brick originating from the external environment or by rehydration, however, are only likely to occur when there is a gradient from a wet interior to a drying surface. The potential, therefore, for salt crystallisation in the ground is, therefore, low.

### **10.13.3 Risk Assessment**

10.13.3.1 There seems to be little published information as regards the resistance to clay bricks/pipes in aggressive ground conditions, however, clay bricks are generally considered very durable. As no significant concentrations of chemical contaminants have been identified at this site in combination with near neutral pH conditions it is considered unlikely that ground conditions are sufficiently aggressive to cause damage to brickwork/clay pipes.

10.13.3.2 Some basic guidance is provided in BS5628-3: 2005 '*Code of Practice for the Use of Masonry - Part 3: Materials and components, design and workmanship*' with regards to resistance of masonry to resist the effects of sulphate attack.

## **10.14 Mortar**

**10.14.1** Mortars are based on building sands mixed with cement and/or lime as a binder. In the UK Portland cements and masonry cement are commonly used. Masonry cements are a mixture of Portland Cements and fine mineral filler (i.e. Limestone) with an air entraining agent.

### **10.14.2 Hazards**

**10.14.2.1** Mortar is subject to the same agents for deterioration as concrete with the major cause of deterioration being sulphate attack.

### **10.14.3 Risk assessment**

**10.14.3.1** Sulphates can originate from soils/groundwater or from the bricks themselves. Calcium, magnesium, sodium and potassium sulphates are present in almost all fired-clay bricks. Water can dissolve a fraction of these sulphates and transport them to the mortar.

**10.14.3.2** Currently, we are not aware of any guidance on the resistance of mortars to sulphate attack. The Building Research Establishment report that the sulphate resistance of mortar was improved by the use of sulphate resisting Portland cements and lime. Some guidance is also provided in BS5628-3: 2005 '*Code of Practice for the use of Masonry - Part 3: Materials and components, design and workmanship*'.

**10.14.3.3** Based on ground conditions determined at the site the risk of significant sulphate attack on mortars (Based on testing/analysis of sulphates in relation to concrete - refer Section 10.7) is considered low.

## **10.15 Metals - general**

**10.15.1** There are a number of metals which are used in buildings either as piles, services, non-structural and, indeed, structural components. The most common metals used in buildings are steel, stainless steel, copper, lead, zinc, aluminium and cast iron. All these metals can deteriorate through corrosion process. Corrosion can affect metals in a variety of ways depending upon the nature of the metal and the environment to which it is subjected. In most common forms of corrosion are:-

- Electrochemical - the most common form of corrosion in an aqueous solution
- Chemical corrosion - occurs when there is a direct charge transfer between the metal and the attacking medium (examples are oxidation, attack by acids, alkalis and organic solvents)
- Microbial induced corrosion

## **10.16 Metals - Cast iron**

**10.16.1** Cast iron is a term to describe ferrous metals containing more than 1.7% carbon and is used extensively in the manufacture of pipes.



**10.16.2 Hazards**

**10.16.2.1** Generally, cast iron has a good resistance to corrosion by soils, however, corrosion can occur due to the following mechanisms:-

- 1) Generation of large scale galvanic cells caused by differences in salt concentrations, oxygen availability or presence of stray electrical currents.
- 2) Hydrochloric acid will cause corrosion at any concentration and temperature. Dilute sulphuric, nitric and phosphoric acids are also aggressive as also are well aerated organic acids.

**10.16.3 Risk assessment**

**10.16.3.1** Testing can be carried out on site to measure the resistivity and redox potential of soils which can assist in deriving recommendations for protection of cast iron components using coatings, burial trenches, or isolation techniques. Currently, however, there is no specific guidance and we recommend advice is sought from manufacturers.

**10.16.3.2** Guidelines produced by the Water Research Centre (WRc) on the use of ductile iron pipes, state that highly acidic soils (pH <5) are corrosive to cast iron pipe even when protected by a zinc coating or polythene sleeving. WRc also indicate that groundwater containing >300ppm chloride may corrode even protected cast iron pipes.

**10.16.3.3** On the basis that the pH of soils at the site are not less than 5, and groundwater is unlikely to be in contact with cast iron elements, then the risk of ductile cast iron pipes being affected by acid/chloride attack is considered low. We have not carried out any redox/resistivity testing (considered outside our brief) and thus we cannot comment further with regards to the risks of galvanic action.

**10.17 Metals - Steel piles**

**10.17.1 Hazards**

**10.17.1.1** The corrosion of steel requires the presence of both oxygen and water. In undisturbed natural soils the amount of corrosion of driven steel piles is generally small. In disturbed soils (made ground) however, corrosion rates can be high and normally twice as high as those for undisturbed natural soils.

**10.17.2 Risk Assessment**

**10.17.2.1** Guidance on the use of steel piles in different environments is provided in British Steel's piling handbook which includes calculating the effective life of steel piles. There is no specific guidance, however, for contaminated soils in this publication. Coatings can be provided to the pile surface but experience has shown that some coatings can be damaged during driving, particularly in ground which can contain hard materials such as brick/concrete/stone.

## **10.18 Metals - Stainless steel**

### **10.18.1 Hazards**

10.18.1.1 Stainless steel is used in a number of building components including services, pipework, reinforcement bars and wall ties. There is little knowledge, however, of the performance of stainless steel in aggressive environments.

### **10.18.2 Risk assessment**

10.18.2.1 Stainless steel can withstand pH of 6.5 to 8.5, but the chlorine content of a soil increases the risk of corrosion. At concentrations of 200mg/l type 304 stainless steel can be used, but for concentrations of 200 to 1000mg/l type 316 should be used in preference to type 304, but for concentrations greater than 1000mg/l type 316 should always be used.

10.18.2.2 At this site the pH of the natural soils was near neutral (within the range of 6.5 to 8.5) and it is considered unlikely that groundwater will be in contact with stainless steel components (unless we are advised otherwise) thus the risk of ground conditions at the site affecting stainless steel is considered low.

## **10.19 Metals - Galvanised steel**

### **10.19.1 Hazards**

10.19.1.1 Galvanising steel is a means of protecting steel from aggressive environments; however, zinc galvanising can be corroded by salts and acids.

### **10.19.2 Risk assessment/remedial action**

10.19.2.1 There is no current specific guidance on the effects of aggressive ground conditions on galvanised steel, however, some research indicates zinc alloys are generally more resistant than pure zinc coatings in aggressive conditions.

## **10.20 Metals - Copper**

### **10.20.1 Hazards**

10.20.1.1 Copper is commonly used for gas and water supplies. Copper is generally resistant to corrosion in most natural environments, but in contaminated ground copper can be subject to corrosion by acids, sulphates, chlorides and ground containing cinders/ash. Wet peat (pH 4.6) and acid clays (pH 4.2) are considered aggressive conditions to promote corrosion to copper.

### **10.20.2 Risk assessment**

10.20.2.1 There is no specific published guidance on what constitutes aggressive conditions to copper except very acid/peaty conditions.

10.20.2.2 There are no significantly acidic or peaty conditions in near surface soils at the site or, indeed, significant concentrations of ash/cinders. On this basis the risk of significant corrosion to copper in contact with the ground is considered low.

## **10.21 Metals - Lead**

### **10.21.1 Hazards**

10.21.1.1 Lead is used in tanking, flashings, damp proof courses, etc. Lead is a durable material which is resistant to corrosion in most environments. Lead damp proof courses can be subject to attack from the lime released by Portland Cement based mortar and concrete. In the presence of moisture, a slow corrosive attack is initiated on lead sheet. In such cases a thick coat of bitumen should be used to protect the lead damp proof course.

### **10.21.2 Risk assessment**

10.21.2.1 There is no current guidance on the performance of lead in contact with contaminated soils, however, acids and alkalis (lime) could be aggressive towards lead.

10.21.2.2 At the site pH conditions are not considered significantly extreme and this it is considered unlikely that ground conditions at the site would significantly affect lead.

## **10.22 Plastics - General**

10.22.1 The range of plastics in construction is wide and increasing. The deterioration of plastics varies with the individual material and the environment to which it is exposed. In general, plastics deteriorate through degradation of their polymer constituent, but loss of plasticizer and other additives can render plastics ultimately unserviceable.

## **10.23 Plastic membranes and geotextiles**

10.23.1 Plastic membranes and textiles are used in the construction industry as damp proof courses, gas resistant membranes, cover systems and liners. They are typically used to restrict the movement of gas or water into buildings, building materials or components or to separate differing soil types. Typically materials used for membranes are polyethylene (PE) and poly vinyl chloride (PVC).

### **10.23.2 Hazards**

10.23.2.1 Membranes of PE and PVC are attacked by a variety of acids and solvents. PE has a poor corrosion resistance to oxidising acids (nitric and sulphuric) at high concentrations. Hydrochloric acid (HCl) does not chemically attack PE but can have a detrimental effect on its mechanical properties. Alkalis, basic salts, ammonia solutions and bleaching chemicals such as chlorine will cause deterioration of PE. PE is resistant to non-oxidising salt solutions.

10.23.2.2 PVC is degraded by the action of oxidising acids. Nitric acid is particularly aggressive towards PVC. PVC does not deteriorate under the action of neutral or alkaline solutions.

### 10.23.3 Risk assessment

10.23.3.1 There is no published guidance on quantitative assessment of the risks to PE or PVC although there is a lot of advice on how contaminants react with these plastics. In general, the more concentrated the contamination the greater the risk to plastic membranes/geotextiles.

10.23.3.2 Based on the investigatory data obtained to date, and in consideration of the hazards described above, there is no evidence of significant concentrations of acids or alkalis, indicating the risks of ground conditions at the site affecting PE and PVC materials are considered low.

## 10.24 Plastic Pipes

### 10.24.1 Hazards

10.24.1.1 Plastic pipes are predominantly manufactured from PVC and PE but other materials can be used. In general they perform well but it is known that chemical attack and permeation of contaminants through the pipes can result from use in contaminated land. A published review on plastic pipes reports the following:-

- Polyethylene (PE) - good resistance to solvents, acids and alkalis
- Poly vinyl chloride (PVC) - most common form of pipe. Good general resistance to chemical attack but can be attacked by solvents such as ketones, chlorinated hydrocarbons and aromatic polypropylene (PP) - chemically resistant to acids, alkalis and organic solvents but not recommended for use with storing oxidising acids, chlorinated hydrocarbons and aromatics.
- Poly vinylidene fluoride (PVDF) - inert to most solvents, acids and alkalis as well as chlorine, bromide and other halogens
- Polytetrafluoroethylene (PTFE) - one of the most inert thermoplastics available. PTFE has good chemical resistance to solvents, acids and alkalis

A survey carried out by the Water Research Centre (WRC) on reported incidents of permeation (more than 25), only two involved PVC with these incidents relating to spillages of fuel.

## **10.24.2 Assessment**

**10.24.2.1** A survey carried out by the Water Research Centre (WRC) on reported incidents of permeation (more than 25), only two involved PVC with these incidents relating to spillages of fuel.

The UK Water Industry research (UKWIR) have published a document entitled '*Guidance for the selection of Water supply pipes to be used in Brownfield sites*'. The publication defines brownfield sites as

*'Land or premises that have been used or developed. They may also be vacant, or derelict. However they are not necessarily contaminated'*

The subject site has not previously been developed and is not considered to be a brownfield site as defined by the UKWIR publication. In addition laboratory test data for polycyclic aromatic hydrocarbons (PAHs) produced no or very limited concentrations above detectable limits. Based on this evidence we are of the opinion that special precautions are unlikely to be required for water supply pipe. We recommend United Utilities is however consulted on this to gain their opinion and requirements.

## **10.25 Electrical cables**

### **10.25.1 Hazards**

**10.25.1.1** Electrical cables are generally protected by plastic sleeves. These sleeves are potentially subject to chemical and permeation in similar modes as plastic pipes. Medium and low voltage cables are often laid directly into the ground and are thus at risk of attack by contaminants. High voltage cables tend to be laid in trenches backfilled with 'clean' materials.

### **10.25.2 Risk assessment/remedial action**

**10.25.2.1** The selection of appropriate sheathing material is important to provide resistance to ground conditions at the site and recommend manufacturers' advices are sought.

## **10.26 Rubbers**

### **10.26.1 Hazards**

**10.26.1.1** Rubbers are crosslinked polymeric materials containing a number of additives such as carbon black, fillers, antioxidant and vulcanising agents. The corrosion resistance of rubber is dependent upon the polymeric constituent. The mechanisms by which rubbers deteriorate when placed in aggressive chemical environments are similar to those described for plastics. Oxidation is the principal form of degradation. Whilst rubbers are resistant to strong acids and alkalis, they are rapidly attacked by oxidising agents such as nitric acid and oxidising salts such as copper, manganese and iron.

10.26.1.2 Rubber is also susceptible to attack by certain hydrocarbons and oils. The absorption of these liquids causes the rubber to smell.

**10.26.2 Risk assessment/remedial action**

10.26.2.1 Information on the effect of a range of chemicals on the physical properties of various rubbers has been produced by the Rubber and Plastics Research Association. This was based on observations carried out following immersion tests using undiluted chemicals, but this has limitations such as the effects of combined chemicals and the effects of dilution.

10.26.2.2 We recommend manufacturers of the rubber materials likely to be in contact with the ground at the site are consulted to confirm, or otherwise, the applicability of their product.

## 11 Landfill issues

- 
- 11.1 Disposal of soils off site
  - 11.2 Landfill tax
  - 11.3 Reuse of soils – Materials Management Plans
- 

### 11.1 Disposal of soils off site

- 11.1.1 Disposal of waste soils must comply with the Landfill Directive and amendments to the '*Landfill (England and Wales) Regulations*'. Essentially, this requires the 'waste producer' to classify soils for off-site disposal to an appropriately licensed landfill facility. Laboratory testing on soils from the site would be required to allow such classification in accordance with current Environment Agency waste acceptance criteria and procedures. We can carry such testing and an assessment of soil classification for disposal on further instructions.

### 11.2 Landfill tax

- 11.2.1 Disposal of soils to landfill sites is normally subject to landfill tax with rates varying from year to year based on government policy. Current information on rates of landfill tax can be obtained from the HM Revenue and Customs website. ([www.hmrc.gov.uk](http://www.hmrc.gov.uk)).

### 11.3 Reuse of Soils - Materials Management Plans

- 11.3.1 Where soils are to be moved and reused onsite, or are to be imported to the site, a Waste Exemption or an Environmental Permit is required.
- 11.3.2 An alternative is the use of a Materials Management Plan (MMP) to determine where soils are and are not considered to be a waste. By following '*The Definition of Waste: Development Industry Code of Practice*' published by CL:AIRE (produced in 2008 and revised in March 2011), soils that are suitable for reuse without the need for remediation (either chemical or geotechnical) and have a certainty of use, are not considered to be waste and therefore do not fall under waste regulations. In addition, following this guidance may present an opportunity to transfer suitable material between sites, without the need for Waste Exemptions or Environmental Permits.
- 11.3.3 MMPs offering numerous benefits, including maximising the use of soils onsite, minimising soils going to landfill and reducing costs and time involved in liaising with waste regulators.
- 11.3.4 We can provide further advice on this and provide fees for producing a Materials Management Plan on further instructions.

## 12 Further investigations

12.1 Although we have endeavoured to provide a comprehensive investigation for the proposed development within budgetary constraints there are areas, which we recommend further investigations be carried out. These are as follows: -

- Further onsite intrusive investigations are undertaken in areas where foundations require deepening to determine if such low strength soils are laterally/vertically extensive. Alternatively a suitably qualified Geo-Environmental Engineer could attend site during the excavation of trenches for foundations located in the affected areas who would be able to provide an indication when suitable founding strata has been reached. This would be based on the observations outlined above, in addition to insitu testing of clay soils achieving undrained shear strengths of at least 60kN/m<sup>2</sup>.
- Further insitu CBR testing using a TRL DCP probe along proposed access roads and hardstanding may yield a value above 3% which would decrease the required formation thickness and provide associated cost savings.
- Precautionary testing to determine hardness values within surface waters of Higgin Brook onsite which will enable a more detailed risk assessment to be completed in relation to water receptors.

12.2 We would be pleased to carry out any of the supplementary investigations described above and provide proposals with costings on further instructions.



## **13 Remediation strategy and specification**

- 13.1.1** We have not identified any significant chemical or gaseous contamination at the subject site, therefore, remediation is not considered necessary. It is recommended, however, that hardness values within surface waters of Higgin Brook are determined to enable a more detailed risk assessment to be completed in relation to water receptors.

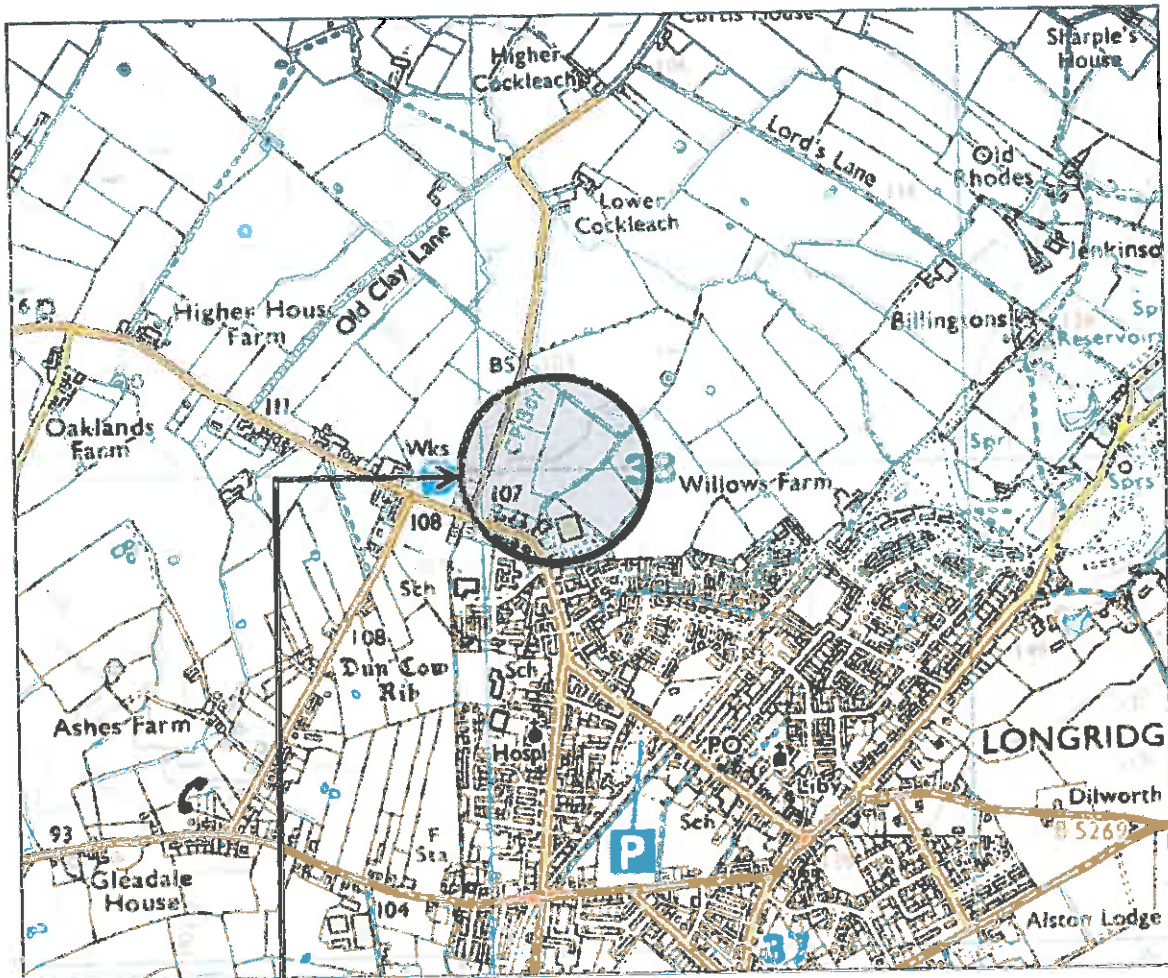

**Approximate area of investigation**

Title	Scale	Drawing number
Site location plan	Not to scale	01

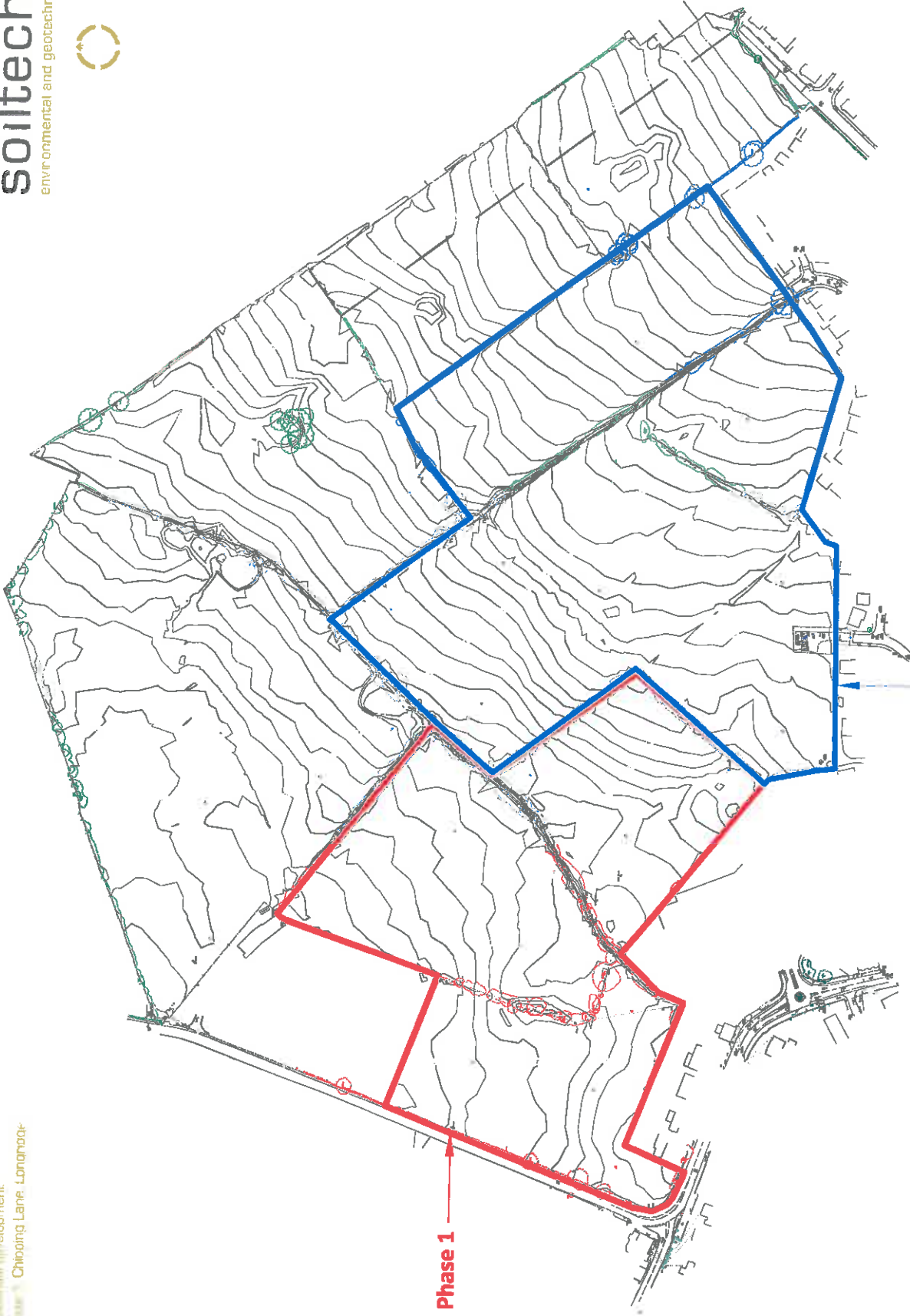

**Phase 1**

**Phase 2**

Title

Plan showing existing site features and location and extent of development phases

Scale

1:2500 at A3

Drawing number

02a



- Key**
- TP Approximate location of trial pit excavation
  - TP Approximate location of trial pit excavation with infiltration testing
  - DTS Approximate location of borehole formed by Driven Tube Sampling techniques with standpipe installation
  - DTS Approximate location of borehole formed by Driven Tube Sampling techniques
  - DCP Approximate location of Dynamic Cone Penetration testing

**Notes**

Base drawing from topographical survey undertaken by Survey and Design Limited

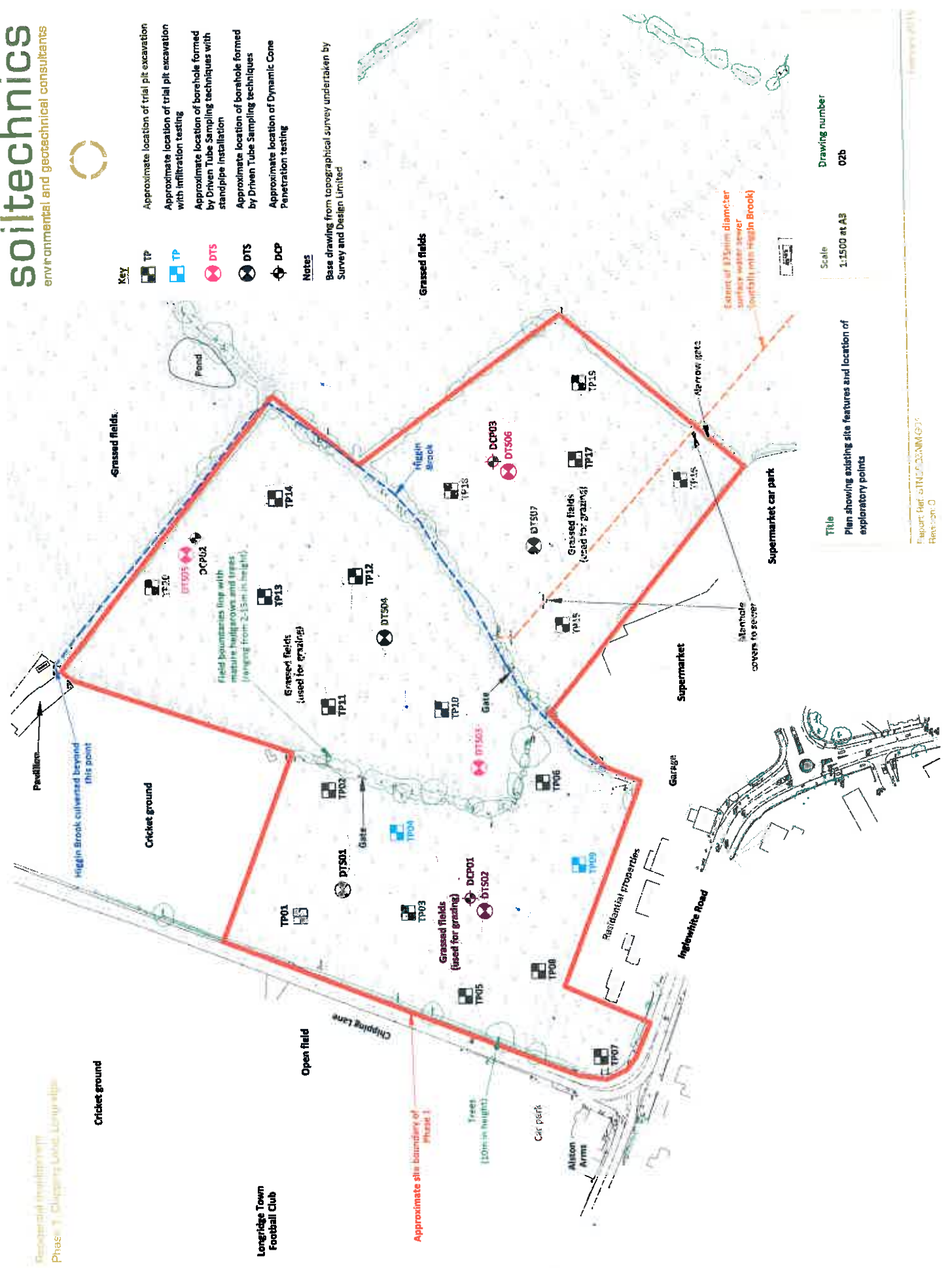

**Title**  
 Plan showing existing site features and location of exploratory points

**Scale**  
 1:1500 at A3

**Drawing number**  
 02b



- Key**
- TP Approximate location of trial pit excavation
  - TP Approximate location of trial pit excavation with infiltration testing
  - DTS Approximate location of borehole formed by Driven Tube Sampling techniques with standpipe installation
  - DTS Approximate location of borehole formed by Driven Tube Sampling techniques
  - DCP Approximate location of Dynamic Cone Penetration testing

**Notes**

Base drawing from topographical survey undertaken by Survey and Design Limited



Approximate site boundary of Phase 1

Title  
Plan showing site development proposals and location of exploratory points

Scale  
1:1500 at A3

Drawing number  
03

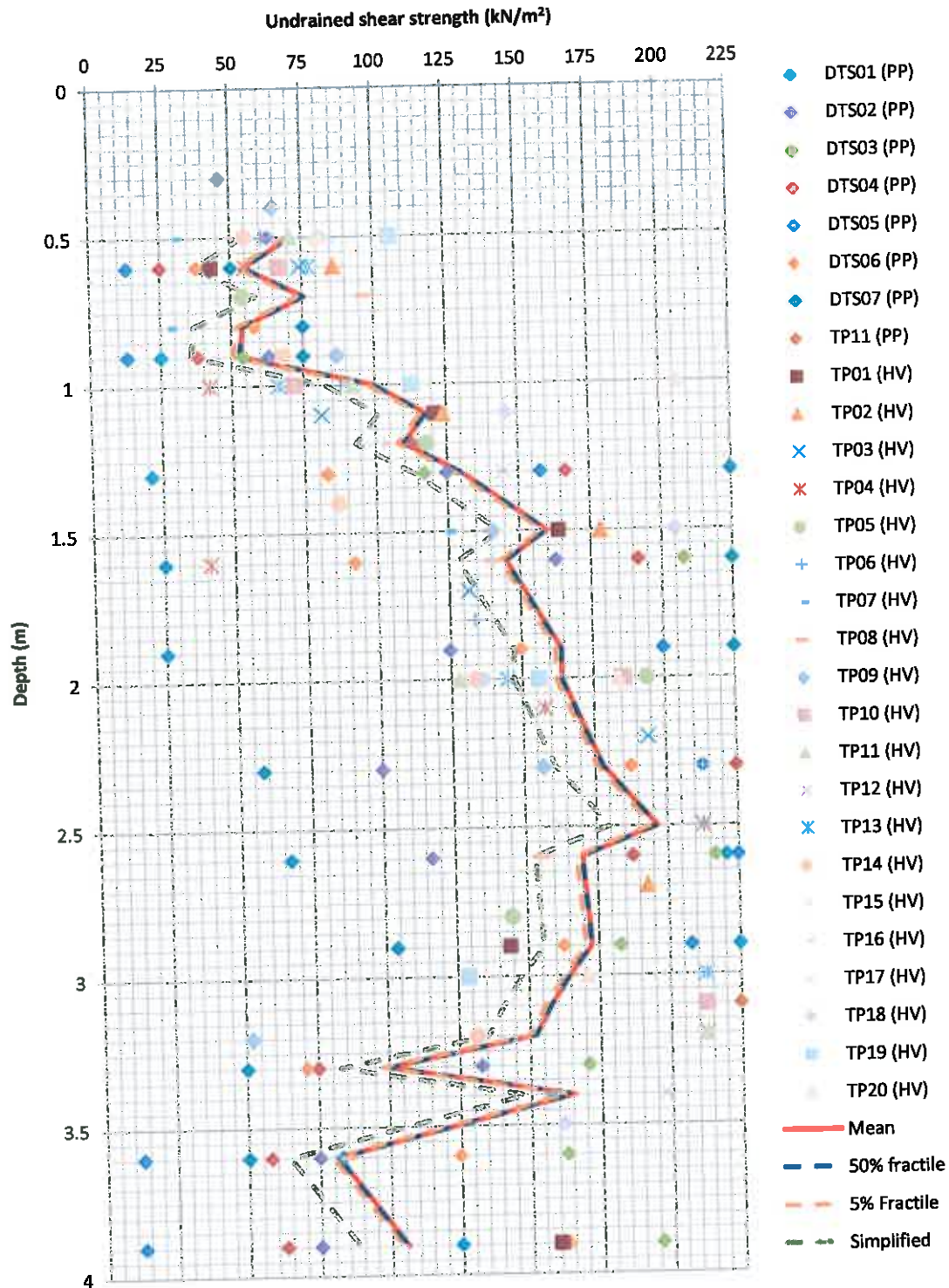

**Notes**

- 1) Equivalent undrained shear strength derived by multiplying Pocket Penetrometer (PP) results by 50

Title	Scale	Drawing number
Plot summarising results of pocket penetrometer and shear vane determinations by location	As shown	04

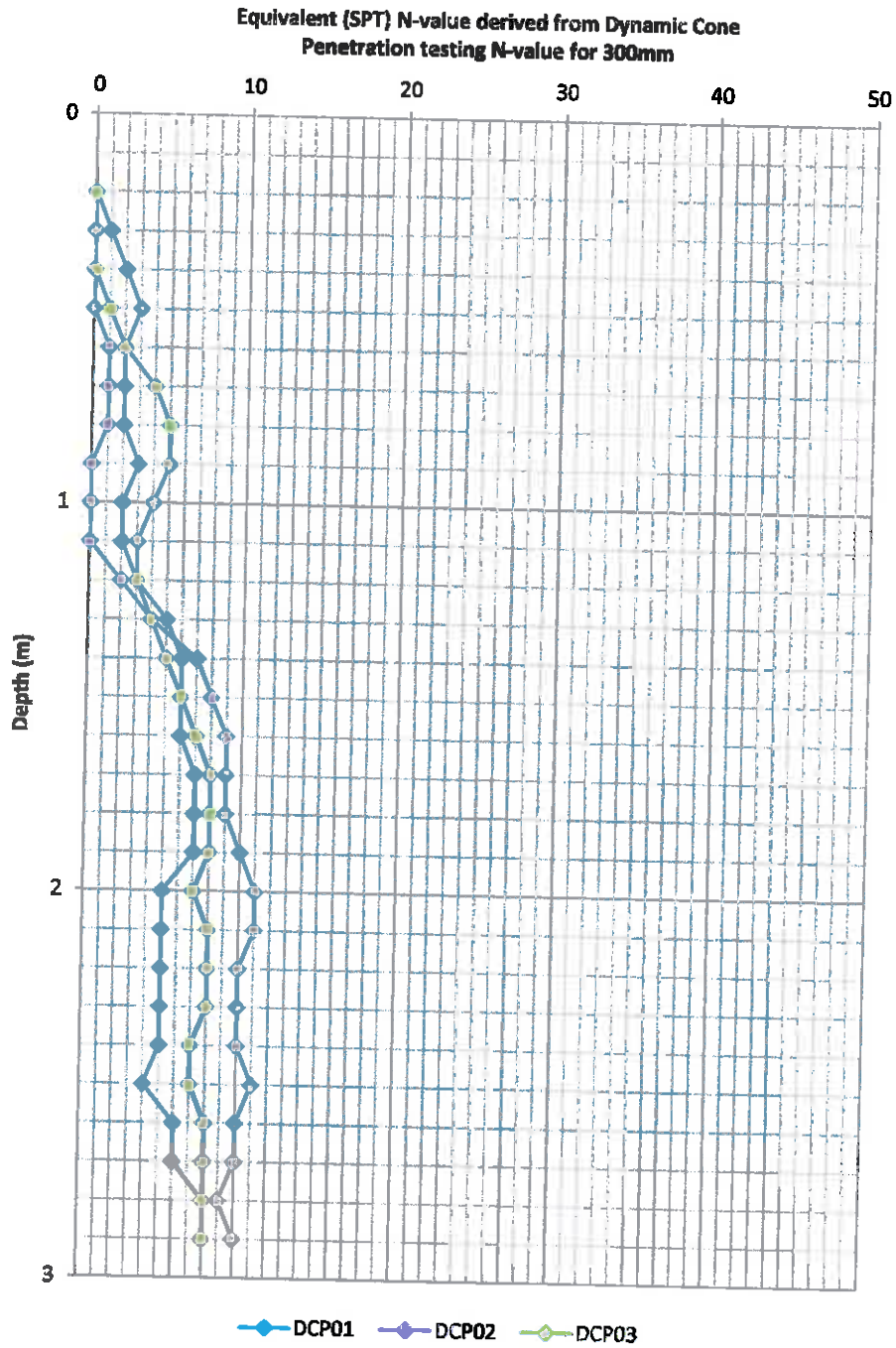

Title

Plot summarising insitu density testing utilising dynamic cone penetration (DCP) techniques

Scale

As shown

Drawing number

05

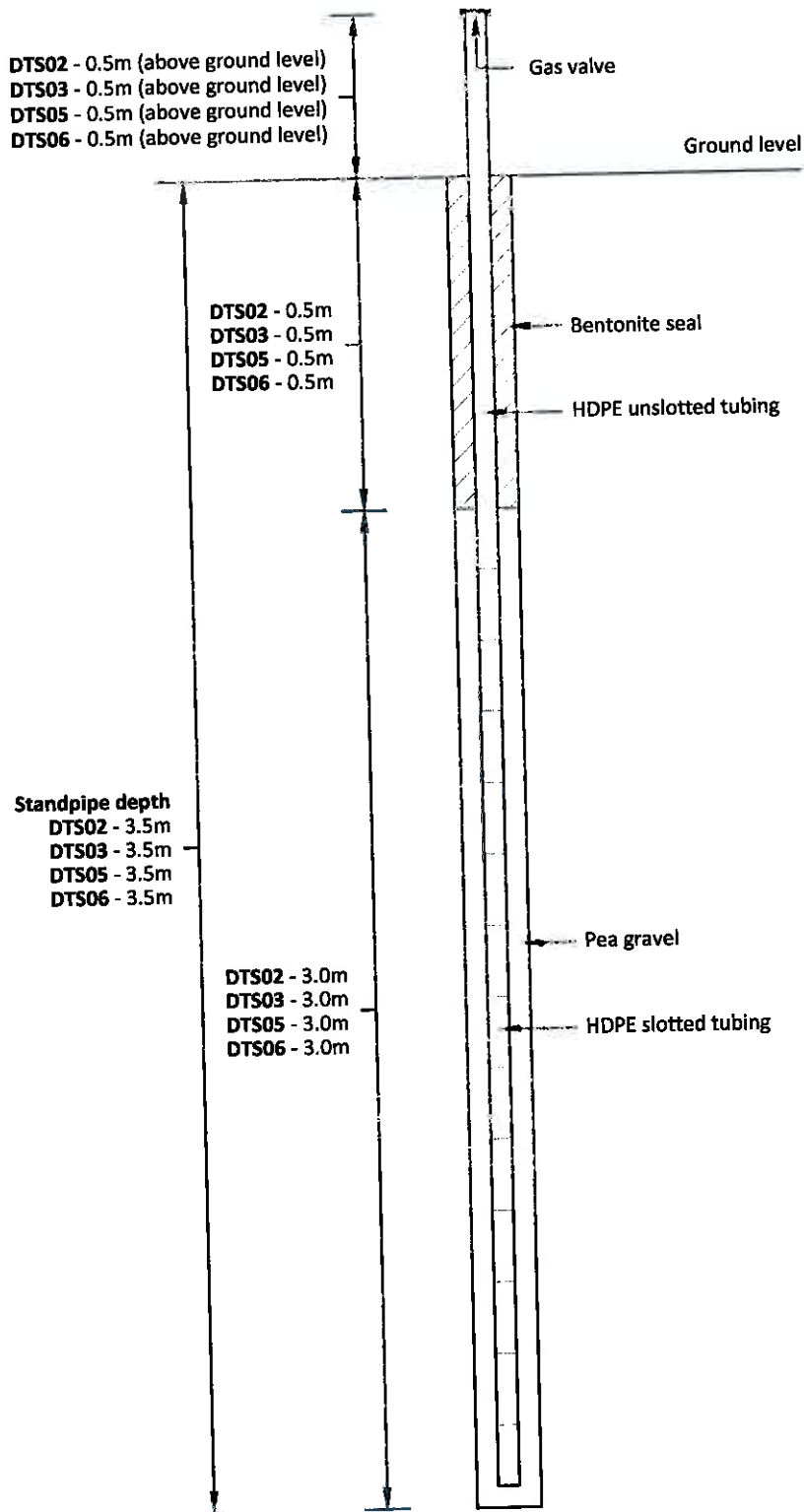

Title

Section showing construction of gas monitoring standpipes installed in boreholes DTS02, DTS03, DTS05 and DTS06

Scale

Not to scale

Drawing number

06





**Key**

- TP
- TP
- DTS
- DTS
- DCP

- Area in which foundations will require deepening to depths of up to 2.2m
- Area in which foundations will require deepening to depths of up to 1.2m
- Area in which foundations will require deepening to depths of up to 1.1m

**Notes**

Base drawing from topographical survey undertaken by Survey and Design Limited



**Title**

Plan showing site development proposals, location of exploratory points and areas in which foundations are likely to require deepening

**Scale**

1:1500 at A3

**Drawing number**

07

## Definition of geotechnical terms used in this report - foundations

***Strip foundations.***

A foundation providing a continuous longitudinal ground bearing.

***Trench fill concrete foundation.***

A trench filled with mass concrete providing continuous longitudinal ground bearing.

***Pad foundation.***

An isolated foundation to spread a concentrated load.

***Raft foundation.***

A foundation continuous in two directions, usually covering an area equal to or greater than the base area of the structure.

***Substructure.***

That part of any structure (including building, road, runway or earthwork) which is below natural or artificial ground level. In a bridge this includes piers and abutments (and wing walls), whether below ground level or not, which support the superstructure.

***Piled foundations and end bearing piles.*** A pile driven or formed in the ground for transmitting the weight of a structure to the soil by the resistance developed at the pile point or base and the friction along its surface. If the pile supports the load mainly by the resistance developed at its point or base, it is referred to as an end-bearing pile; if mainly by friction along its surface, as a friction pile.

***Bored cast in place pile.***

A pile formed with or without a casing by excavating or boring a hole in the ground and subsequently filling it with plain or reinforced concrete.

***Driven pile.***

A pile driven into the ground by the blows of a hammer or a vibrator.

***Precast pile.***

A reinforced or prestressed concrete pile cast before driving.

***Driven cast in place pile.***

A pile installed by driving a permanent or temporary casing, and filling the hole so formed with plain or reinforced concrete.

***Displacement piles.***

Piled formed by displacement of the soil or ground through which they are driven.

***Skin friction.***

The frictional resistance of the surrounding soil on the surface of cofferdam or caisson walls, and pile shafts.

***Downdrag or negative skin friction.*** A downwards frictional force applied to the shaft of a pile caused by the consolidation of compressible strata, e.g. under recently placed fill. Downdrag has the effect of adding load to the pile and reducing the factor of safety.

## Definition of geotechnical terms used in this report – bearing values

***Ultimate bearing capacity.***

The value of the gross loading intensity for a particular foundation at which the resistance of the soil to displacement of the foundation is fully mobilised.

***Presumed bearing value.***

The net loading intensity considered appropriate to the particular type of ground for preliminary design purposes. The particular value is based on calculation from shear strength tests or other field tests incorporating a factor of safety against shear failure.

***Allowable bearing pressure.***

The maximum allowable net loading intensity at the base of the foundation, taking into account the ultimate bearing capacity, the amount and kind of settlement expected and our estimate of ability of the structure to accommodate this settlement.

***Factor of safety.***

The ratio of the ultimate bearing capacity to the intensity of the applied bearing pressure or the ratio of the ultimate load to the applied load.

## Definition of geotechnical terms used in this report – road pavements

The following definitions are based on Transport and Road Research Laboratory (TRRL) Report LR1132.

***Equilibrium CBR values.***

A prediction of the CBR value, which will be attained under the completed pavement.

***Thin pavement.***

A thin pavement (which includes both bound and unbound pavement construction materials 1 in 300mm thick and a thick pavement is 1200mm thick (typical of motorway construction).

## Definition of geo-environmental terms used in this report

### ***Conceptual model***

Textual and/or schematic hypothesis of the nature and sources of contamination, potential migration pathways (including description of the ground and groundwater) and potential receptors, developed on the basis of the information obtained from the investigatory process.

### ***Contamination***

Presence of a substance which is in, on or under land, and which has the potential to cause harm or to cause pollution of controlled water.

### ***Controlled water***

Inland freshwater (any lake, pond or watercourse above the freshwater limit), water contained in underground strata and any coastal water between the limit of highest tide or the freshwater line to the three mile limit of territorial waters.

### ***Harm***

Adverse effect on the health of living organisms, or other interference with ecological systems of which they form part, and, in the case of humans, including property.

### ***Pathway***

Mechanism or route by which a contaminant comes into contact with, or otherwise affects, a receptor.

### ***Receptor***

Persons, living organisms, ecological systems, controlled waters, atmosphere, structures and utilities that could be adversely affected by the contaminant(s).

### ***Risk***

Probability of the occurrence of, and magnitude of the consequences of, an unwanted adverse effect on a receptor.

### ***Risk Assessment***

Process of establishing, to the extent possible, the existence, nature and significance of risk.

## Definition of environmental risk/hazard terms used in this report.

Based on CIRIA report C552 'Contaminated land risk assessment – A guide to good practice'.

### Potential hazard severity definition

Category	Definition
<b>Severe</b>	Acute risks to human health, catastrophic damage to buildings/property, major pollution of controlled waters
<b>Medium</b>	Chronic risk to human health, pollution of sensitive controlled waters, significant effects on sensitive ecosystems or species, significant damage to buildings or structures.
<b>Mild</b>	Pollution of non sensitive waters, minor damage to buildings or structures.
<b>Minor</b>	Requirement for protective equipment during site works to mitigate health effects, damage to non sensitive ecosystems or species.

### Probability of risk definition

Category	Definition
<b>High likelihood</b>	Pollutant linkage may be present, and risk is almost certain to occur in long term, or there is evidence of harm to the receptor.
<b>Likely</b>	Pollutant linkage may be present, and it is probable that the risk will occur over the long term
<b>Low likelihood</b>	Pollutant linkage may be present, and there is a possibility of the risk occurring, although there is no certainty that it will do so.
<b>Unlikely</b>	Pollutant linkage may be present, but the circumstances under which harm would occur are improbable.

### Level of risk for potential hazard definition

Probability of risk	Potential severity			
	Severe	Medium	Mild	Minor
<b>High Likelihood</b>	Very high	High	Moderate	Low/Moderate
<b>Likely</b>	High	Moderate	Low/Moderate	Low
<b>Low Likelihood</b>	Moderate	Low/Moderate	Low	Very low
<b>Unlikely</b>	Low/Moderate	Low	Very low	Very low

Refer sheet 2 for definitions of 'very high' to 'low'

## Definition of environmental risk/hazard terms used in this report.

Based on CIRIA report C552 '*Contaminated land risk assessment – A guide to good practice*'.

### Risk classifications and likely action required:

#### **Very high risk**

High probability that severe harm could arise to a designated receptor from an identified hazard OR there is evidence that severe harm to a designated receptor is currently happening. This risk, if realised is likely to result in substantial liability. Urgent investigation and remediation are likely to be required.

#### **High risk**

Harm is likely to arise to a designated receptor from an identified hazard. This risk, if realised, is likely to result in substantial liability. Urgent investigation is required and remedial works may be necessary in the short term and are likely over the long term.

#### **Moderate risk**

It is possible that harm could arise to a designated receptor from an identified hazard. However, it is either relatively unlikely that any such harm would be severe, or if any harm were to occur it is likely that the harm would be relatively mild. Investigation is normally required to clarify risks and to determine potential liability. Some remedial works may be required in the long term.

#### **Low risk**

It is possible that harm could arise to a designated receptor from an identified hazard but it is likely that this harm, if realised, would at worst normally be mild.

#### **Very low risk**

It is a low possibility that harm could arise to a designated receptor. On the event of such harm being realised it is not likely to be severe.



















### List of documents used in assessment of chemical contamination

No.	Title	Publication reference / publisher
1	Human health toxicological assessment of contaminants in soil	EA Science Report – SC050021/SR2
2	Updated technical background to the CLEA model	EA Science Report – SC050021/SR3
3	CLEA Software (Version 1.03 beta) Handbook	EA Science Report - SC050021/SR4
4	Guidance on comparing Soil Contamination Data with a Critical Concentration	CIEH
5	Generic Assessment Criteria for Human Health Risk Assessment	LQM/CIEH
6	Assessment of Risks to Human Health from Land Contamination: An overview of the development of soil guideline values and related research	R&D Publication, Contaminated Land Report CLR 7
7	Contaminants of Soil: Collation of Toxicological Data and Intake Values for Humans	R&D Publication, Contaminated Land Report CLR 9
8	The Contaminated Land Exposure Assessment Model (CLEA): Technical Basis and Algorithms	R&D Publication, Contaminated Land Report CLR 10
9	Model Procedures for the Management of Land Contamination	R&D Publication, Contaminated Land Report CLR 11
10	Contaminants in Soil: Collection of Toxicological Data and Intake Values for Human Values	R&D Publications, Tox. 6
11	Soil Guideline Values for Contamination (2002)	R&D Publications, SGV 10
12	Soil Guideline Values (2009)	EA Science Reports – SC050021

CIEH Chartered institute of Environmental Health  
LQM Land Quality Management  
EA Environment Agency

## Key to legends

### Composite materials, soils and lithology

	Topsoil		Made Ground		Boulders
	Chalk		Clay		Coal
	Cobbles		Cobbles & Boulders		Concrete
	Gravel		Limestone		Mudstone
	Peat		Sand		Sand and Gravel
	Sandstone		Silt		Silt / Clay
					Siltstone



Note: Composite soil types are signified by combined symbols.

## Key to 'test results' and 'sampling' columns









Test result		Sampling	
Depth	Records depth that the test was carried out (i.e.: at 2.10m or between 2.10m and 2.55m)	From (m) To (m)	Records depth of sampling
Result	PID - Photo Ionisation Detector result (ppm equivalent Isobutylene)  PP - Pocket penetrometer result (kN/m <sup>2</sup> ) HVP - Hand held shear vane result (kN/m <sup>2</sup> )  <i>PP result converted to an equivalent undrained shear strength by applying a factor of 50. Where at least 3 results obtained at same depth then an average value may be reported.</i>	Type	D Disturbed sample  B Bulk disturbed sample  ES Environmental sample comprising plastic and/or glass container  W Water sample  CBR Undisturbed sample in mould (California Bearing Ratio)

## Water observations

Described at foot of log and shown in the 'water strike' column.

-  = water level observed after specified delay in excavation
-  = water strike



DESCRIPTION	LEGEND	DEPTH (m)	WATER STRIKE	TEST RESULTS		SAMPLING		
				TYPE/DEPTH (m)	RESULT	FROM (m)	TO (m)	TYPE
Grass onto brown slightly silty sandy organic CLAY with occasional rootlets. TOPSOIL						0.10		D
Firm medium strength brownish grey silty CLAY. DEVENSIAN TILL		0.50		HVP 0.60	43	0.40		D
Stiff high strength brown slightly silty CLAY. DEVENSIAN TILL		1.00		HVP 1.10	121	0.60		D
Stiff very high and high strength brown mottled grey friable CLAY. DEVENSIAN TILL		1.50		HVP 1.50	164	1.00		D
								
								
				HVP 2.90	144			D
		3.60						
Very stiff brown mottled grey slightly gravelly friable CLAY. Gravel consists of medium rounded dolerite. DEVENSIAN TILL				HVP 3.90	160	2.90		D

CONTINUED ON NEXT SHEET

**Notes:** Trial pit sides remained upright and stable upon completion.

**Ground level (mAOD)**

103.99

**Co-ordinates**

360068, 438052

**Title**

Trial pit record

**Surface breaking**

No

**Groundwater observations**

No groundwater encountered.

**Dimensions (W x L)**

0.60m x 2.50m

**Date of excavation (range if applicable)**

03/02/2016

**Appendix**

C

**Method of excavation**

JCB 3CX

**Location plan on drawing number**

02b

**TP01**

DESCRIPTION	LEGEND	DEPTH (m)	WATER STRIKE	TEST RESULTS		SAMPLING		
				TYPE/DEPTH (m)	RESULT	FROM (m)	TO (m)	TYPE
TRIAL PIT TERMINATED AT 4.30m		4.30						

**Notes:** Trial pit sides remained upright and stable upon completion.

**Ground level (mAOD)**  
103.99

**Co-ordinates**  
360068, 438052

**Title**  
Trial pit record

**Surface breaking**  
No

**Groundwater observations**  
No groundwater encountered.

**Dimensions (W x L)**  
0.60m x 2.50m





**Date of excavation (range if applicable)**  
03/02/2016

**Appendix**  
C

**Method of excavation**  
JCB 3CX

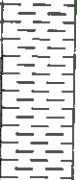
**Location plan on drawing number**  
02b

**TP01**

DESCRIPTION	LEGEND	DEPTH (m)	WATER STRIKE	TEST RESULTS		SAMPLING			
				TYPE/DEPTH (m)	RESULT	FROM (m)	TO (m)	TYPE	
Grass onto brown slightly silty very sandy organic CLAY with occasional gravels of quartzite and frequent rootlets. TOPSOIL							0.20		D
Firm to stiff high strength reddish brown slightly sandy slightly gravelly silty CLAY. Gravel consists of medium quartzite. DEVENSIAN TILL		0.40		HVP 0.60	86		0.60		D
Stiff high to very high strength reddish brown mottled bluish grey slightly silty CLAY. DEVENSIAN TILL		1.00		HVP 1.10	124				
		1.80		HVP 1.50	179		1.50		D
Very stiff very high strength reddish brown mottled grey slightly silty slightly sandy friable CLAY with occasional gravels of medium sandstone. DEVENSIAN TILL		2.80		HVP 2.70	193		2.70		D
TRIAL PIT TERMINATED AT 2.80m									

**Notes:** Trial pit sides remained upright and stable upon completion.

<b>Ground level (mAOD)</b> 104.10	<b>Co-ordinates</b> 360117, 438038	<b>Title</b> Trial pit record	<b>Surface breaking</b> No
<b>Groundwater observations</b> No groundwater encountered.	<b>Dimensions (W x L)</b> 0.60m x 2.50m	<b>Date of excavation (range if applicable)</b> 03/02/2016	<b>Appendix</b> C
	<b>Method of excavation</b> JCB 3CX	<b>Location plan on drawing number</b> 02b	<b>TP02</b>

DESCRIPTION	LEGEND	DEPTH (m)	WATER STRIKE	TEST RESULTS		SAMPLING		
				TYPE/DEPTH (m)	RESULT	FROM (m)	TO (m)	TYPE
Grass onto light brown very sandy slightly organic CLAY with frequent rootlets. TOPSOIL						0.10		D
Soft to firm medium to high strength brownish grey slightly sandy silty CLAY. DEVENSIAN TILL		0.50		HVP 0.60	74	0.60		D
...from 1.1m depth, becoming sandy.				HVP 1.10	81	1.10		D
				HVP 1.70	132			
		2.00		HVP 2.20	194			
Very stiff very high strength greyish brown slightly silty slightly sandy CLAY. DEVENSIAN TILL						2.70		D
TRIAL PIT TERMINATED AT 2.80m		2.80						

**Notes:** Trial pit sides remained upright and stable upon completion.

**Ground level (mAOD)**  
104.70

**Groundwater observations**  
Slight groundwater seepage from 1.5m depth, insufficient to record in base of trial pit after completion.

**Co-ordinates**  
360062, 458004

**Dimensions (W x L)**  
0.60m x 2.50m

**Method of excavation**  
JCB 3CX

**Title**  
Trial pit record

**Date of excavation (range if applicable)**  
03/02/2016

**Location plan on drawing number**  
02b

**Surface breaking**  
No

**Appendix**  
C

**TP03**

DESCRIPTION	LEGEND	DEPTH (m)	WATER STRIKE	TEST RESULTS		SAMPLING		
				TYPE/DEPTH (m)	RESULT	FROM (m)	TO (m)	TYPE
Grass onto brown sandy organic CLAY with frequent rootlets. TOPSOIL						0.10		D
Firm medium strength brownish grey slightly sandy silty CLAY. DEVENSIAN TILL		0.60		HVP 0.60	55	0.70		D
Firm to soft medium strength brownish grey very silty CLAY with occasional rounded gravels of medium to coarse sandstone and mudstone. DEVENSIAN TILL		1.00	▼	HVP 1.00	42	1.20		D
				HVP 1.60	41			
Very stiff very high strength grey slightly silty sandy CLAY. DEVENSIAN TILL		2.00		HVP 2.10	158			
				HVP 2.50	213	2.70		D
				HVP 3.20	213	3.20		D
TRIAL PIT TERMINATED AT 3.60m		3.60						

**Notes:** Trial pit sides remained upright and stable upon completion. Infiltration testing performed at 1.5m, following which trial pit extended to a depth of 3.6m depth.

**Ground level (mAOD)**  
105.35

**Co-ordinates**  
360098, 438008

**Title**  
Trial pit record

**Surface breaking**  
No

**Groundwater observations**  
Slight groundwater seepage from 1.1m depth, insufficient to record in base of trial pit after completion.

**Dimensions (W x L)**  
0.60m x 2.50m

**Date of excavation (range if applicable)**  
03/02/2016

**Appendix**  
C

**Method of excavation**  
JCB 3CX

**Location plan on drawing number**  
02b

**TP04**

DESCRIPTION	LEGEND	DEPTH (m)	WATER STRIKE	TEST RESULTS		SAMPLING		
				TYPE/DEPTH (m)	RESULT	FROM (m)	TO (m)	TYPE
Grass onto brown sandy organic CLAY with frequent rootlets. TOPSOIL		0.40				0.10		D
Firm medium strength greyish brown slightly sandy silty CLAY with occasional gravels of medium quartzite and sandstone. DEVENSIAN TILL		0.90		HVP 0.70	54	0.60		D
Stiff high strength reddish brown mottled orange grey silty CLAY with occasional gravels of medium to coarse quartzite and sandstone and cobbles of the same. DEVENSIAN TILL		1.70		HVP 1.20	118	1.00 1.10		D D
Very stiff very high strength brown mottled grey silty friable CLAY. DEVENSIAN TILL		2.30		HVP 2.00	194	1.80		D
<i>L. from 2.6m depth, becoming sandy.</i>				HVP 2.80	145	2.80		D
----- TRIAL PIT TERMINATED AT 2.90m		2.90						

**Notes:** Trial pit sides remained upright and stable upon completion.

**Ground level (mAOD)**  
105.30

**Groundwater observations**  
Slight groundwater seepage from 2.6m depth, insufficient to record in base of trial pit after completion.

**Co-ordinates**  
360024, 437979

**Dimensions (W x L)**  
0.60m x 2.50m

**Method of excavation**  
JCB 3CX

**Title**  
Trial pit record

**Date of excavation (range if applicable)**  
03/02/2016

**Location plan on drawing number**  
02b

**Surface breaking**  
No

**Appendix**  
C

**TP05**

DESCRIPTION	LEGEND	DEPTH (m)	WATER STRIKE	TEST RESULTS		SAMPLING		
				TYPE/DEPTH (m)	RESULT	FROM (m)	TO (m)	TYPE
Grass onto orange brown sandy organic CLAY with frequent rootlets. TOPSOIL						0.10		D
Firm to stiff medium to high strength orangish brown silty CLAY with occasional gravels of medium sandstone. DEVENSIAN TILL		0.40		HVP 0.50	61	0.50	1.00	ES
<i>...0.1m diameter ceramic land drain trending north to south encountered in side of trial pit at 0.7m depth.</i>						0.60		D
<i>...from 0.8m depth, becoming reddish brown in colour.</i>								
				HVP 1.00	88	1.00		D
<i>...from 1.5m depth, becoming mottled grey.</i>								
				HVP 1.80	134			
Stiff very high strength reddish brown mottled grey slightly silty slightly gravelly sandy friable CLAY with occasional cobbles of sandstone. Gravel consists of medium to coarse rounded sandstone. DEVENSIAN TILL		2.00				2.00		D
			▼	HVP 2.50	213			
				HVP 3.00	213	3.00		D
----- TRIAL PIT TERMINATED AT 3.10m		3.10						

Notes: Trial pit sides remained upright and stable upon completion.

**Ground level (mAOD)**  
106.15

**Co-ordinates**  
260119, 437942

**Title**  
Trial pit record

**Surface breaking**  
No

**Groundwater observations**  
Slight groundwater seepage from 2.5m depth, insufficient to record in base of trial pit after completion.

**Dimensions (W x L)**  
0.60m x 2.50m

**Date of excavation (range if applicable)**  
03/02/2016

**Appendix**  
C

**Method of excavation**  
JCB 3CX

**Location plan on drawing number**  
02b

**TP06**

DESCRIPTION	LEGEND	DEPTH (m)	WATER STRIKE	TEST RESULTS		SAMPLING		
				TYPE/DEPTH (m)	RESULT	FROM (m)	TO (m)	TYPE
Grass onto brown very clayey organic SAND with frequent rootlets. TOPSOIL		0.40				0.10		D
Soft low strength brown very sandy CLAY with occasional gravels of medium rounded sandstone. DEVENSIAN TILL		1.20		HVP 0.50	30	0.70		D
				HVP 0.80	28			
Stiff high strength greyish brown slightly sandy silty CLAY. DEVENSIAN TILL		1.20		HVP 1.50	125	1.50		D
<i>From 2.5m depth, becoming reddish brown in colour.</i>								
<i>From 3m depth, becoming very stiff.</i>								
TRIAL PIT TERMINATED AT 3.50m		3.50		HVP 3.40 PP 3.40	156 143	3.40		D

Notes: Trial pit sides remained upright and stable upon completion.

Ground level (mAOD)  
106.99

Groundwater observations  
Slight groundwater seepage from 2.0m depth, insufficient to record in base of trial pit after completion.

Co-ordinates  
359996, 437919

Dimensions (W x L)  
0.60m x 2.50m

Method of excavation  
JCB 3CX

Title  
Trial pit record

Date of excavation (range if applicable)  
03/02/2016





Location plan on drawing number  
02b

Surface breaking  
No

Appendix  
C

**TP07**



DESCRIPTION	LEGEND	DEPTH (m)	WATER STRIKE	TEST RESULTS		SAMPLING		
				TYPE/DEPTH (m)	RESULT	FROM (m)	TO (m)	TYPE
Grass onto brown very sandy organic CLAY with frequent rootlets. TOPSOIL						0.10		D
Firm high strength orangish brown mottled grey silty CLAY with occasional gravels of medium sandstone. DEVENSIAN TILL		0.35				0.40		D
Firm to stiff high strength reddish brown mottled grey silty CLAY with occasional roots. DEVENSIAN TILL		0.80		HVP 0.70	97			D
				HVP 1.60	141	1.50		D
Very stiff very high strength reddish brown mottled grey slightly silty CLAY. DEVENSIAN TILL		2.20						
				HVP 2.60	156			
Stiff to firm high strength reddish brown slightly silty sandy CLAY. DEVENSIAN TILL		3.00						
						3.40		D
				HVP 3.60	85			
TRIAL PIT TERMINATED AT 3.70m		3.70						

Notes: Trial pit sides remained upright and stable upon completion.

Ground level (mAOD)  
106.85

Co-ordinates  
360035, 437946

Title  
Trial pit record

Surface breaking  
No

Groundwater observations  
No groundwater encountered.

Dimensions (W x L)  
0.60m x 2.50m

Date of excavation (range if applicable)  
03/02/2016

Appendix  
C

Method of excavation  
JCB 3CX

Location plan on drawing number  
02b

**TP08**

DESCRIPTION	LEGEND	DEPTH (m)	WATER STRIKE	TEST RESULTS		SAMPLING			
				TYPE/DEPTH (m)	RESULT	FROM (m)	TO (m)	TYPE	
Grass onto brown sandy organic CLAY with occasional gravels of medium sandstone and frequent rootlets. TOPSOIL		0.30					0.10		D
Firm medium strength becoming high strength orangish grey silty sandy CLAY. DEVENSIAN TILL				HVP 0.40	65				
<u>0.1m diameter ceramic land drain trending north to south encountered in side of trial pit at 0.7m depth.</u>									
<u>...from 0.8m depth, becoming mottled grey.</u>									
Firm to stiff high strength orangish grey silty CLAY. DEVENSIAN TILL		1.00		HVP 0.90	87		1.00		D
Firm to stiff high strength orangish grey silty CLAY. DEVENSIAN TILL				HVP 1.50	141		1.50		D
Stiff very high strength brownish grey slightly silty CLAY with occasional gravels of medium rounded sandstone. DEVENSIAN TILL		1.90							
				HVP 2.30	157		2.20		D
Firm medium strength brownish grey sandy gravelly CLAY. Gravel consists of medium sandstone. DEVENSIAN TILL		2.80							
				HVP 3.20	52		3.20		D
TRIAL PIT TERMINATED AT 3.30m									
		3.30							

**Notes:** Trial pit sides remained upright and stable upon completion. Infiltration testing performed at 1.7m, following which trial pit extended to a depth of 3.3m.

**Ground level (mAOD)**  
106.70

**Groundwater observations**  
No groundwater encountered.

**Co-ordinates**  
360082, 437927

**Dimensions (W x L)**  
0.60m x 2.60m

**Method of excavation**  
JCB 3CX

**Title**  
Trial pit record





**Date of excavation (range if applicable)**  
03/02/2016

**Location plan on drawing number**  
02b

**Surface breaking**  
No

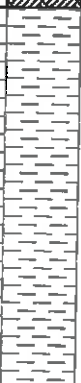
**Appendix**  
C

**TP09**

DESCRIPTION	LEGEND	DEPTH (m)	WATER STRIKE	TEST RESULTS		SAMPLING		
				TYPE/DEPTH (m)	RESULT	FROM (m)	TO (m)	TYPE
Grass onto brown very sandy organic CLAY with occasional gravels of medium sandstone and frequent rootlets. TOPSOIL						0.10		B
Firm medium becoming high strength orangish grey silty CLAY with occasional gravels of rounded sandstone. DEVENSIAN TILL		0.40		HVP 0.60	67	0.50		B
<i>...from 0.8m depth, becoming mottled grey and stiff.</i>				HVP 1.00	72	1.00		ES
Stiff very high strength grey mottled brown slightly silty friable CLAY. DEVENSIAN TILL		1.50		HVP 2.00	186	1.80		B
Stiff very high strength grey mottled brown slightly silty slightly sandy friable CLAY with occasional gravels of rounded sandstone. DEVENSIAN TILL		3.00		HVP 3.10	213	3.10		B
TRIAL PIT TERMINATED AT 3.20m		3.20						

Notes: Trial pit sides remained upright and stable upon completion.

Ground level (mAOD) 105.98	Co-ordinates 360153, 437987	Title Trial pit record	Surface breaking No
Groundwater observations No groundwater encountered.	Dimensions (W x L) 0.60m x 2.50m	Date of excavation (range if applicable) 04/02/2016	Appendix C
	Method of excavation JCB 3CX	Location plan on drawing number 02b	<b>TP10</b>

DESCRIPTION	LEGEND	DEPTH (m)	WATER STRIKE	TEST RESULTS		SAMPLING		
				TYPE/DEPTH (m)	RESULT	FROM (m)	TO (m)	TYPE
Grass onto orange brown sandy slightly organic CLAY with occasional gravels of medium sandstone and frequent rootlets. TOPSOIL		0.10				0.10		D
Firm medium becoming high strength orangish brown mottled grey slightly silty sandy CLAY. DEVENSIAN TILL <i>...0.1m diameter ceramic land drain trending east to west encountered in side of trial pit at 0.5m depth.</i>		0.50		HVP 0.50	71	0.40		D
<i>...from 0.8m depth, becoming mottled grey and stiff.</i>		1.80		HVP 1.00	92	1.00		D
Very stiff high becoming very high strength bluish grey mottled brown slightly silty CLAY. DEVENSIAN TILL <i>...from 2.7m depth, occasional cobbles of rounded sandstone.</i>		3.30		HVP 2.00	128	2.20		D
				PP 3.10 HVP 3.20	225 213	3.20		D
----- TRIAL PIT TERMINATED AT 3.30m								

**Notes:** Trial pit sides remained upright and stable upon completion.

**Ground level (mAOD)**  
104.49

**Groundwater observations**  
No groundwater encountered.

**Co-ordinates**  
360155, 438038

**Dimensions (W x L)**  
0.60m x 2.50m

**Method of excavation**  
JCB 3CX

**Title**  
Trial pit record

**Date of excavation (range if applicable)**  
04/02/2016

**Location plan on drawing number**  
02b

**Surface breaking**  
No

**Appendix**  
C

**TP11**