

Pool External Stairs Setting Out 1:20

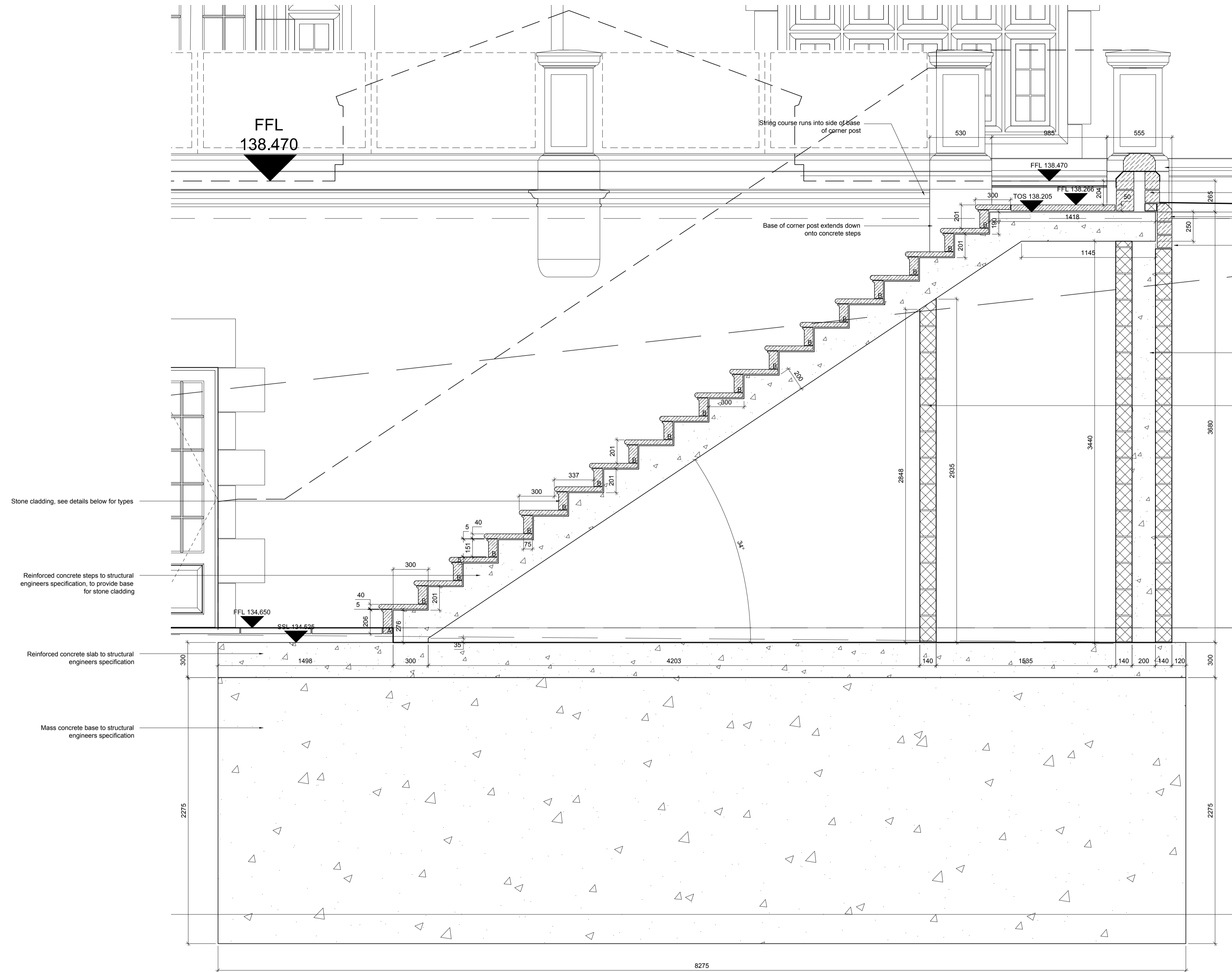

Pool External Stairs Sectional Setting Out 1:20

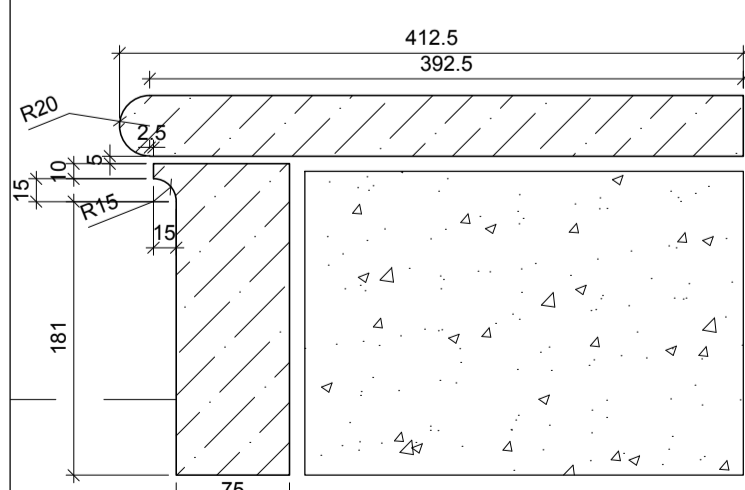

Type A Tread Detail 1:5

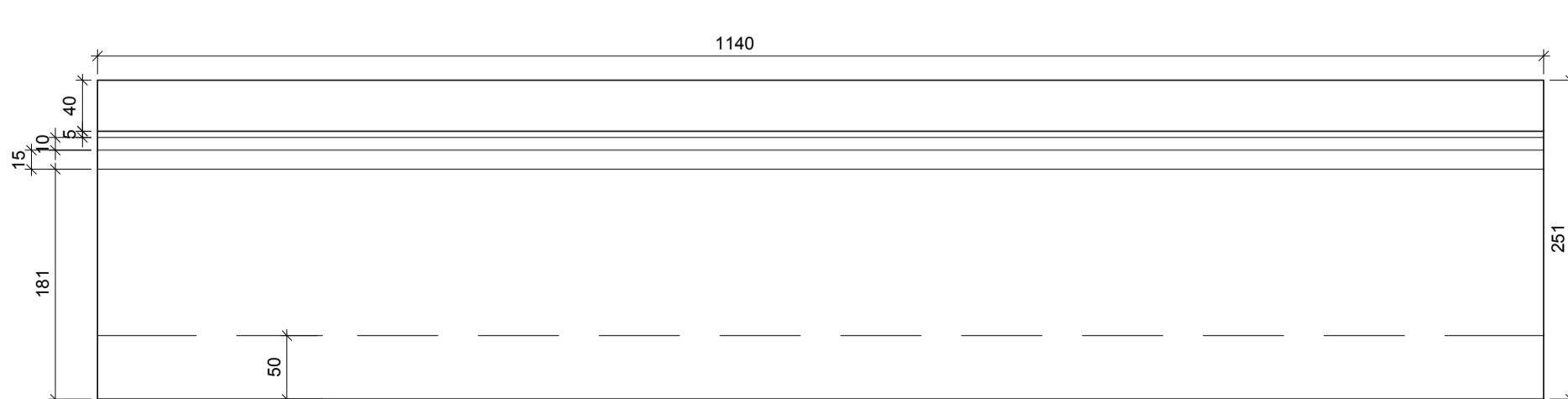

Type B Tread Detail 1:5

- NOTES
- All dimensions and levels are to be checked on site.
 - Any discrepancies are to be reported to the WJS Architects Ltd before any work commences.
 - This drawing shall not be scaled to ascertain any dimensions. Work to figured dimensions only.
 - This drawing shall not be reproduced without express written permission from WJS Architects Ltd.
 - Title overlay drawings and ownership boundaries are produced using all reasonable endeavours. WJS Architects Ltd cannot be responsible for the accuracy or scale discrepancy of base plans supplied to them.

- Corner post to sit on ashlar square cut base to run down into the ground
- Stone balustrade to sit on concrete stair and run down steps, see (90)011 for setting out. No string course down steps
- Cut block along rear of terrace. To be cut stone to section between two posts at top of stair where land banks
- Walling stone below stone coping in area between low posts, min of 300mm to ground level of bank. Stepped DPC in outer stone leaf, min 150mm off ground level.

- Cavity retaining wall to structural engineers specification
- 140mm supporting wall

rev	date	drawn	checked
F	16/10/2015	JR	EJ

CORNER POST DRAWINGS UPDATED, COPING PROFILE REDUCED DOWN TO 275mm, EXTRA STRING COURSE ADDED

rev	date	drawn	checked
E	16/10/2015	JR	EJ

BALUSTRADE REMOVED FOLLOWING MOVE TO METAL RAILINGS. STONE STEP SIZE AMENDED

rev	date	drawn	checked
D	08/07/2015	JR	EJ

DRAWING UPDATED FOR REVISED TERRACE LEVEL. STEP ADDED TO TOP LANDING. 2 NO ADDITIONAL POSTS ADDED AS PER CLIENT REQUEST. STAIR WIDENED BY 125mm TO SQUARE OFF TOP LANDING

rev	date	drawn	checked
C	19/03/15	JR	EJ

DRAWING RE ISSUED AS FULL DRAWING SET UPDATE

rev	date	drawn	checked
B	02/02/2015	JR	EJ

TREAD DETAIL A AND B CORRECTED

rev	date	drawn	checked
A	27/01/2015	JR	EJ

FINISHED FLOOR AND STRUCTURAL HEIGHTS ADDED

drawing stage PRODUCTION INFORMATION
drawing status CONSTRUCTION
client MR AND MRS BOVINGDON
project NEW HALL PENDLINGTON ROAD WISWELL
drawing title EXTERNAL STONEMWORK DETAILS POOL EXTERNAL STEPS

date 19/01/2015 drawn JR
scale 1:20@A1 checked EJ

