

Elevation A
Corner Post Elevation Details 1:5

Elevation B

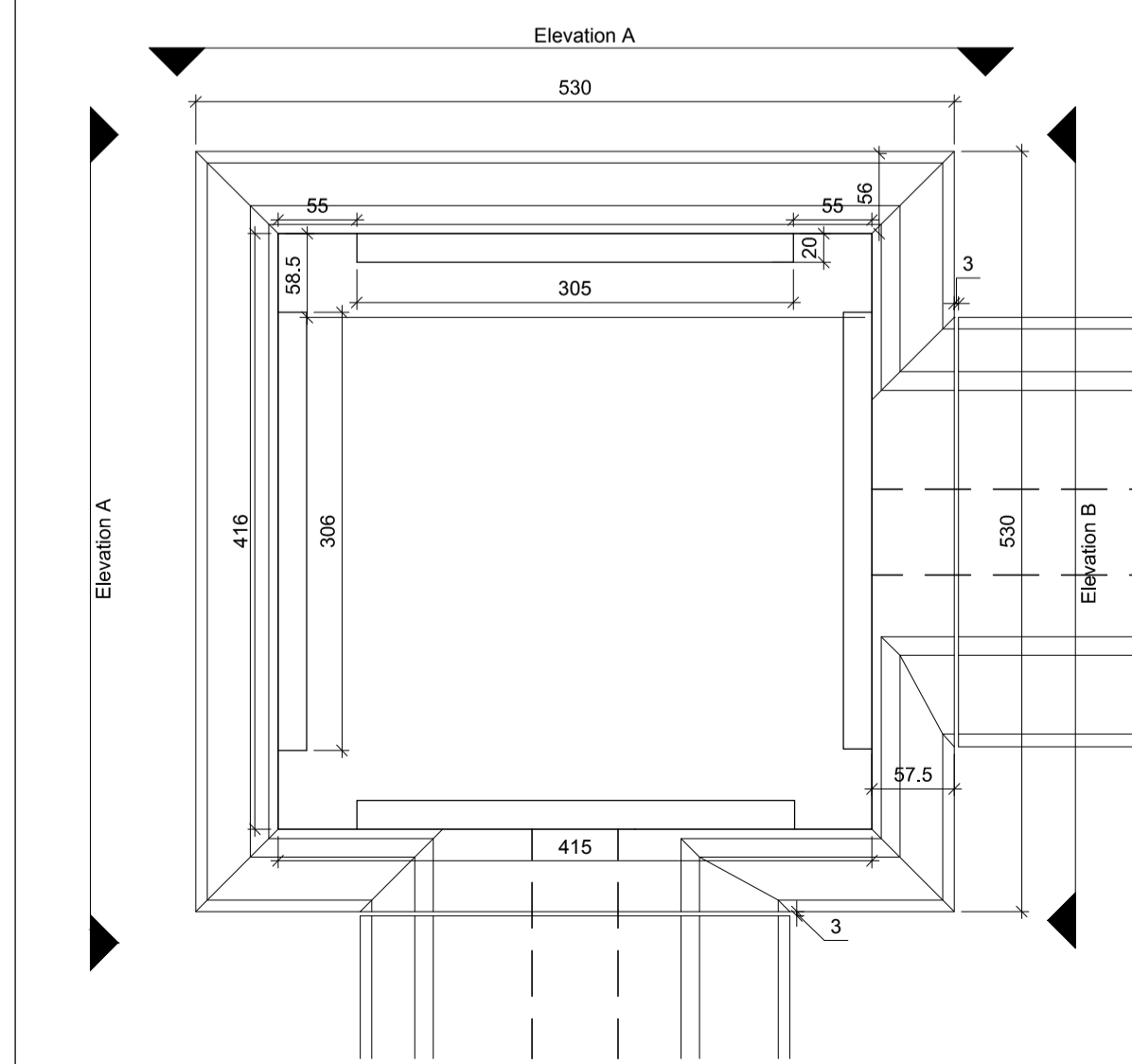

Corner Post Plan Detail 1:5

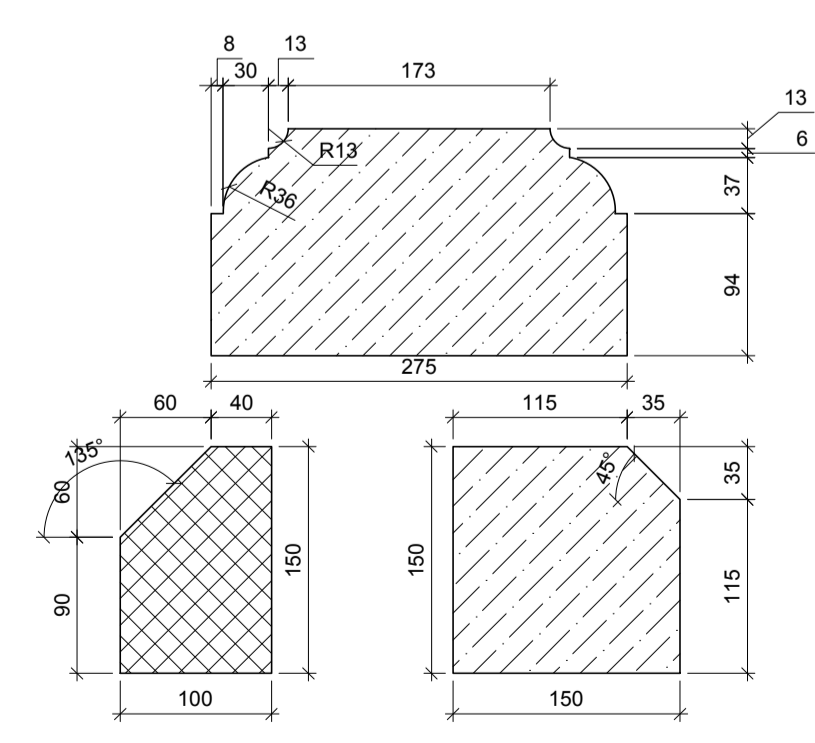

Plinth Detail 1:5

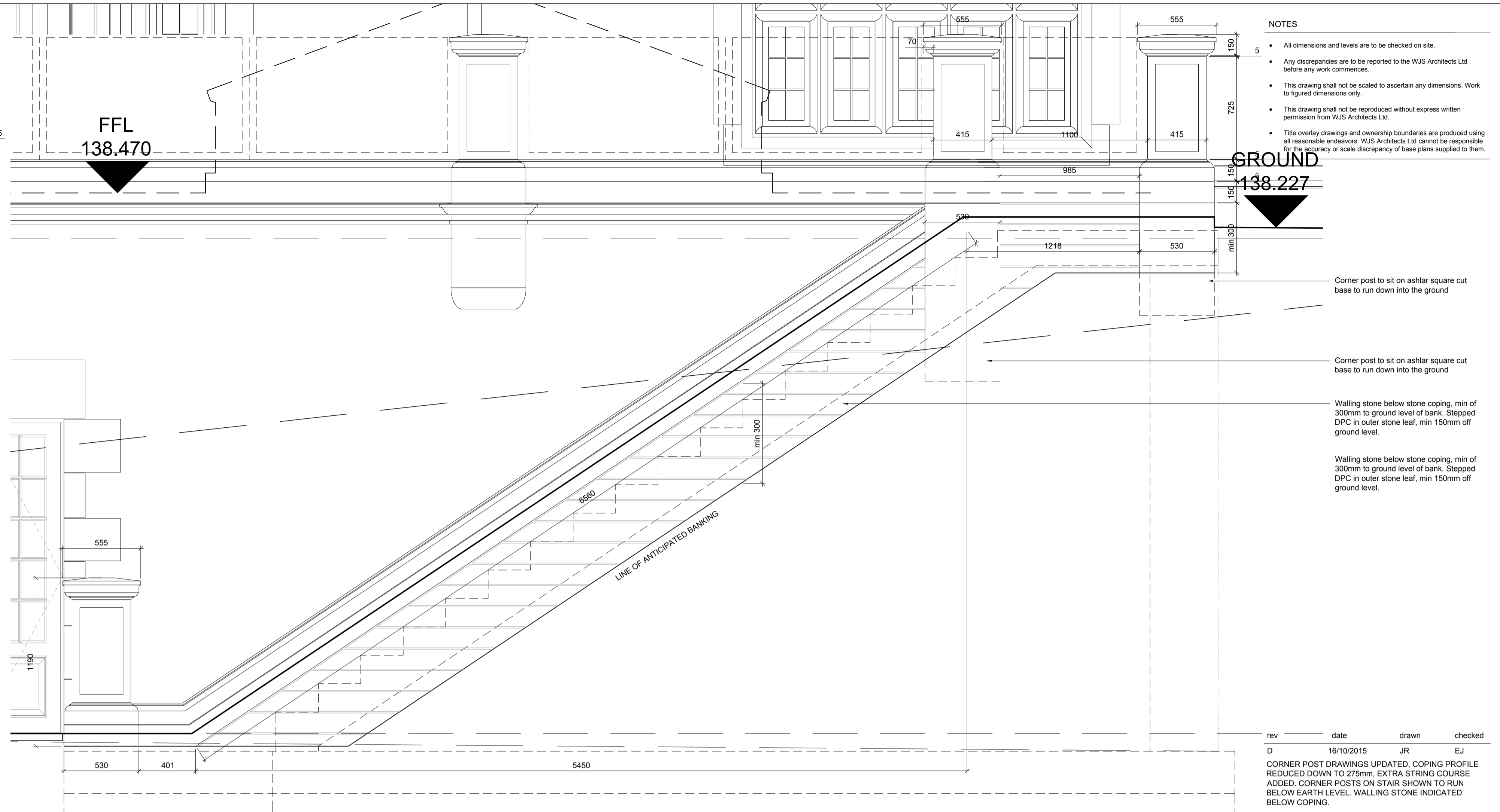

Pool External Stairs Balustrading 1:20

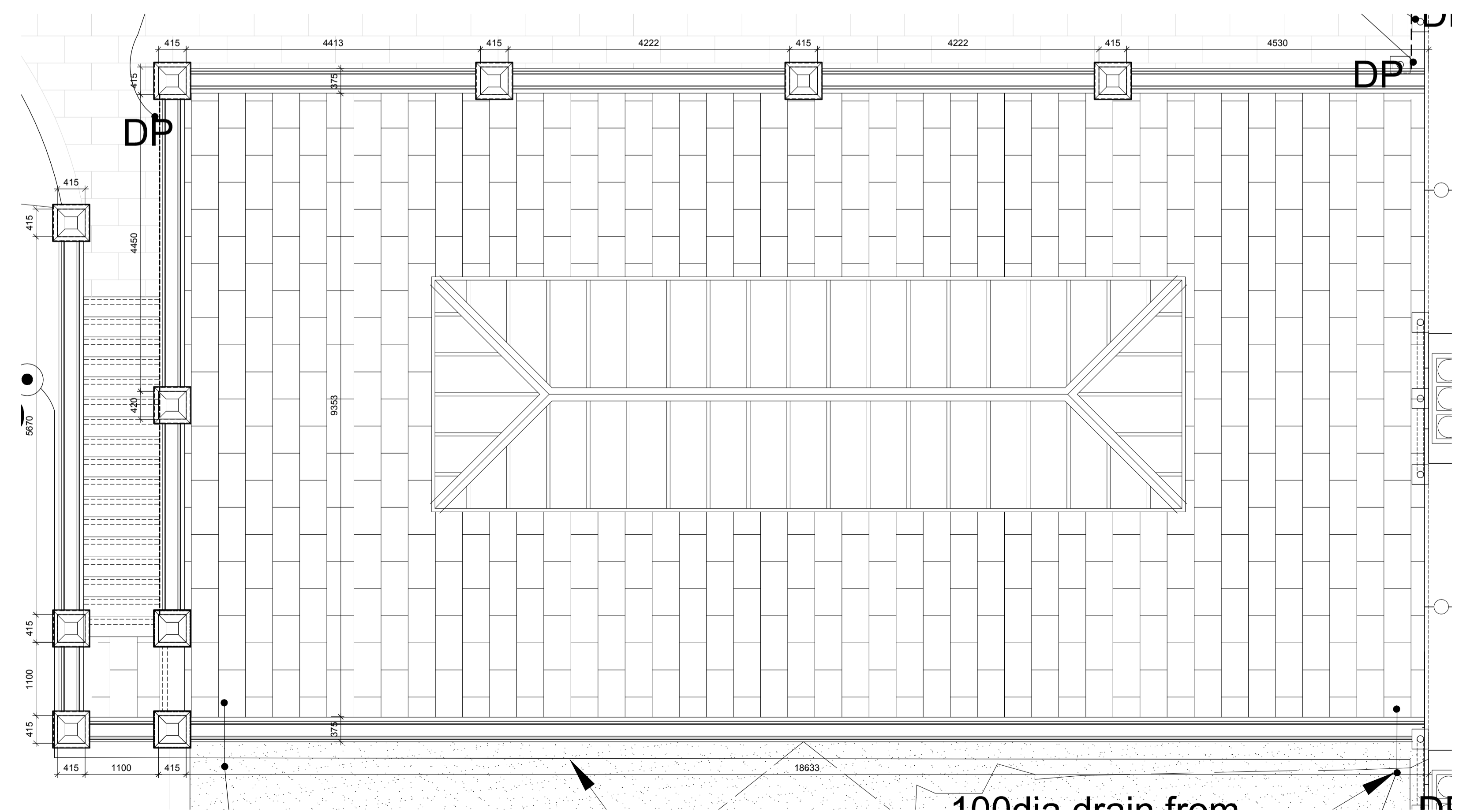

Post Setting Out 1:50

- NOTES
- All dimensions and levels are to be checked on site.
 - Any discrepancies are to be reported to the WJS Architects Ltd before any work commences.
 - This drawing shall not be scaled to ascertain any dimensions. Work to figured dimensions only.
 - This drawing shall not be reproduced without express written permission from WJS Architects Ltd.
 - Title overlay drawings and ownership boundaries are produced using all reasonable endeavours. WJS Architects Ltd cannot be responsible for the accuracy or scale discrepancy of base plans supplied to them.

- Corner post to sit on ashlar square cut base to run down into the ground
- Corner post to sit on ashlar square cut base to run down into the ground
- Walling stone below stone coping, min of 300mm to ground level of bank. Stepped DPC in outer stone leaf, min 150mm off ground level.
- Walling stone below stone coping, min of 300mm to ground level of bank. Stepped DPC in outer stone leaf, min 150mm off ground level.

rev	date	drawn	checked
D	16/10/2015	JR	EJ
CORNER POST DRAWINGS UPDATED. COPING PROFILE REDUCED DOWN TO 275mm. EXTRA STRING COURSE ADDED. CORNER POSTS ON STAIR SHOWN TO RUN BELOW EARTH LEVEL. WALLING STONE INDICATED BELOW COPING.			
rev	date	drawn	checked
C	16/10/2015	JR	EJ
BALUSTRADE REMOVED FOLLOWING MOVE TO METAL RAILINGS. SETTING OUT DIMENSIONS ADDED TO STONE POSTS.			
rev	date	drawn	checked
B	08/07/2015	JR	EJ
DRAWING UPDATED FOR REVISED TERRACE LEVEL. STEP ADDED TO TOP LANDING. 2 NO ADDITIONAL POSTS ADDED AS PER CLIENT REQUEST. STAIR WIDENED BY 125mm TO SQUARE OFF TOP LANDING			
rev	date	drawn	checked
A	19/03/15	JR	EJ
DRAWING RE ISSUED AS FULL DRAWING SET UPDATE			

drawing stage PRODUCTION INFORMATION
drawing status CONSTRUCTION

client MR AND MRS BOVINGDON
project NEW HALL
PENDLETON ROAD
WISWELL

drawing title EXTERNAL STONEMWORK
DETAILS
POOL EXTERNAL STEPS
date 19/01/2015 drawn JR
scale 1:20@A1 checked EJ

SHAW & JAGGER
ARCHITECTS
14 - 15 Regent Parade
Harrogate
North Yorkshire
HG1 5AW
Tel: 01423 532950
info@shawandjagger.com
www.shawandjagger.com

Job No 137/01 (90)010 D
DWG No Rev