

ABBREVIATIONS

- AB Air Brick
- ch: Ceiling Height
- CL Cover Level
- EH Eaves Height
- ffi: Finished Floor Level
- GU Gully
- MH Man Hole
- RH Ridge/Roof Height
- RWP Rain Water Pipe
- SVP Soil Vent Pipe
- TL Threshold Level
- TW Top of Wall
- WP Waste Pipe

NOTE

All levels and coordinates relate to OSG83(15) using GNSS data.
Levels defining edge of carriageway are observed at channel (bottom of kerb).

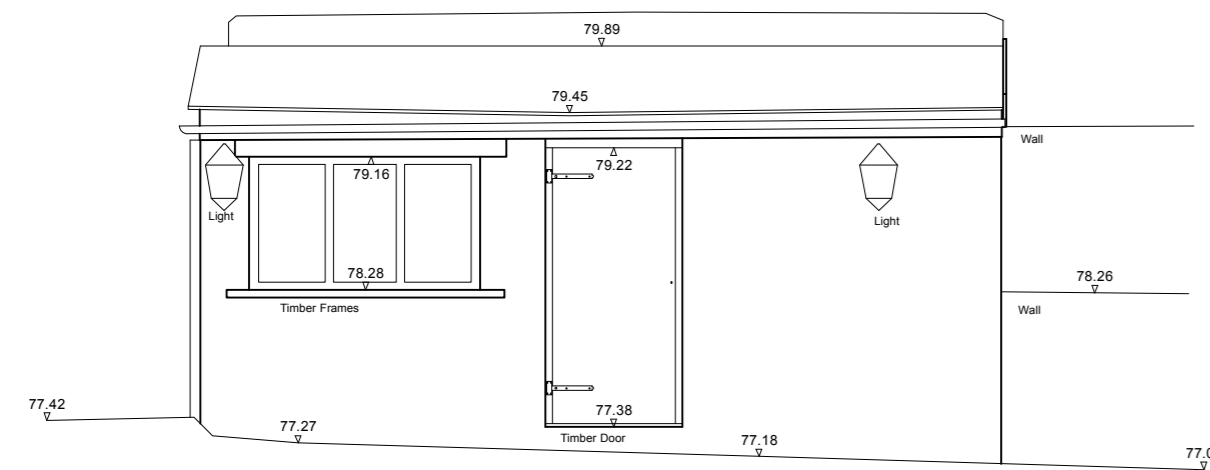

▼ 75.00m above OS Datum
West Elevation

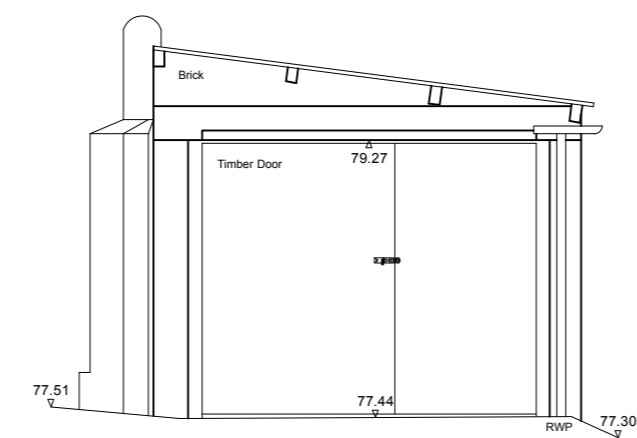

▼ 75.00m above OS Datum
South Elevation

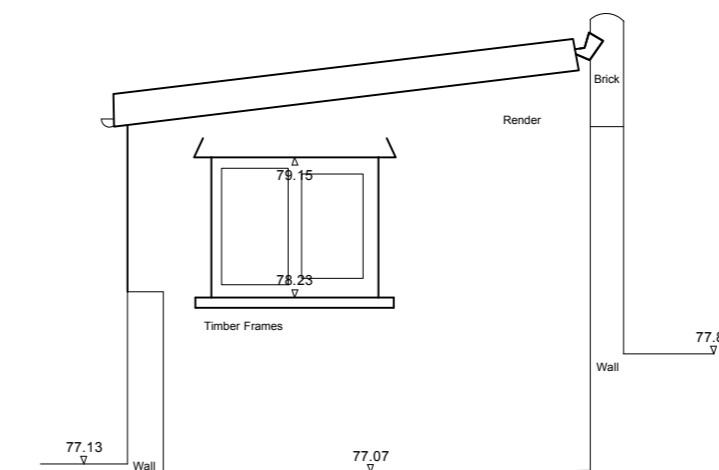

▼ 75.00m above OS Datum
North Elevation

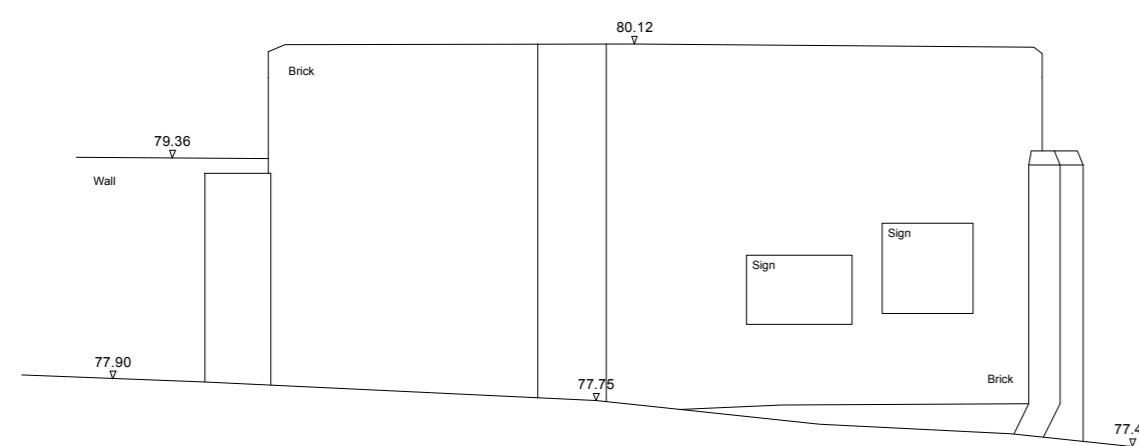

▼ 75.00m above OS Datum
East Elevation

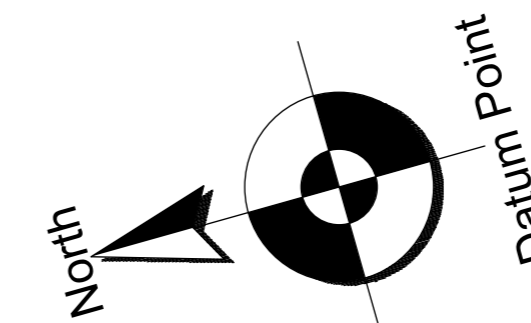
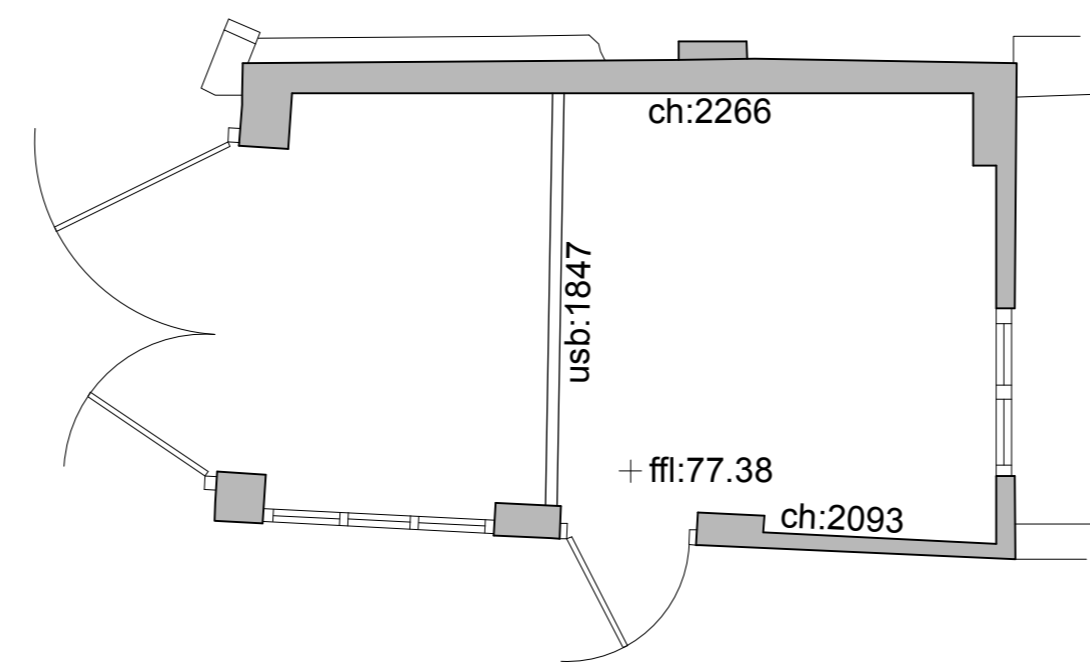

Rev	Date	Description
-	-	-

50 King Street
Clitheroe

Existing Garage Plan and Elevations

Drwg. No.: 2326.E.03 Rev.: -

Date: Nov '16 Scale: 1:50@A1

IWA Architects

Waterloo Mill, Waterloo Road, Clitheroe, Lancashire, BB7 1LR.

t: +44 (0) 1200 423487
f: +44 (0) 1200 458278
e: admin@iwaarchitects.co.uk
w: www.iwaarchitects.co.uk