

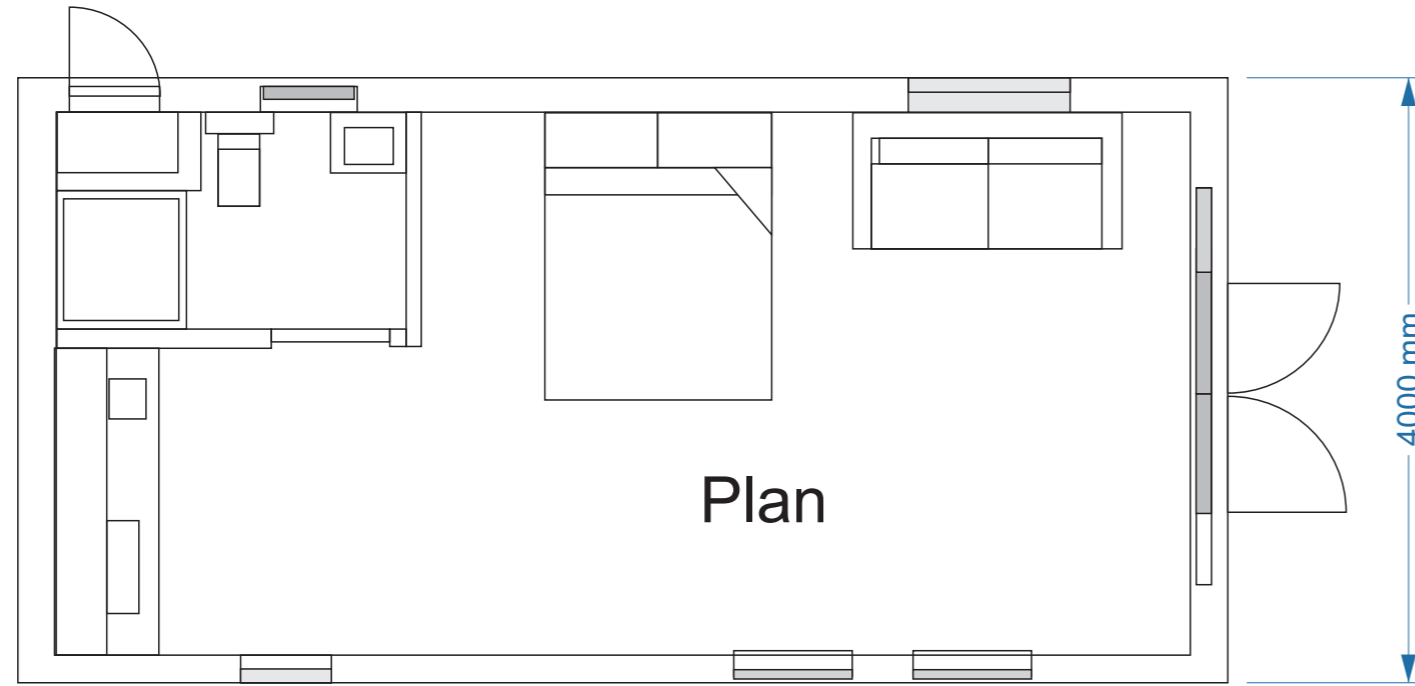

SPECIFICATION

- Cedar exterior cladding
 - EPDM Firestone rubber roof covering
 - 24mm argon double glazed windows & doors
 - BS EN 1647 : 2012 Thermal Class 3
 - Painted and wheeled steel chassis
-
- Brushed steel double sockets with usb where applicable
 - Low energy recessed led lights
 - Low energy exterior led lights
 - TV aerial socket/s
 - lpg combi Boiler and feature tall anthracite radiators
 - 2100mm kitchen with fridge, extractor, microwave, double socket, sink, LPG double hob and oven
 - Toilet, sink, mirror, shower, extractor & heated towel rail
 - Thermal Class 3

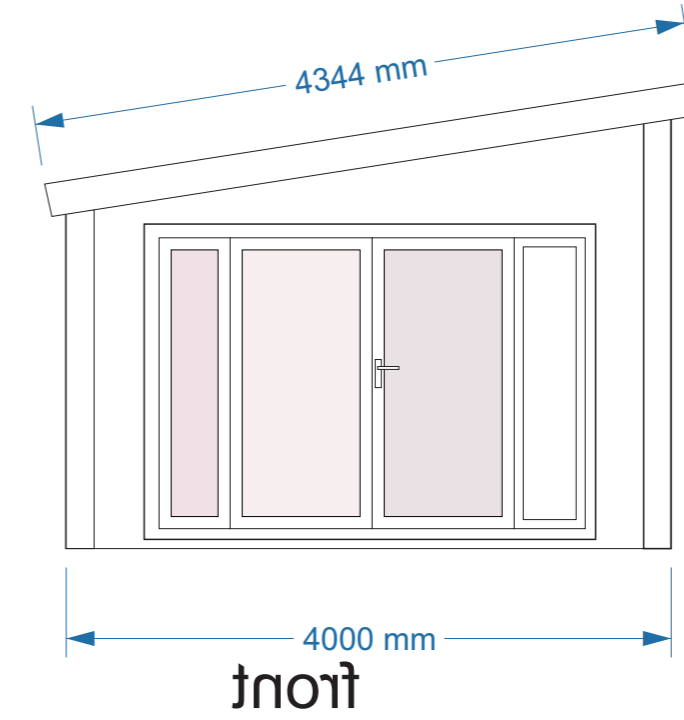

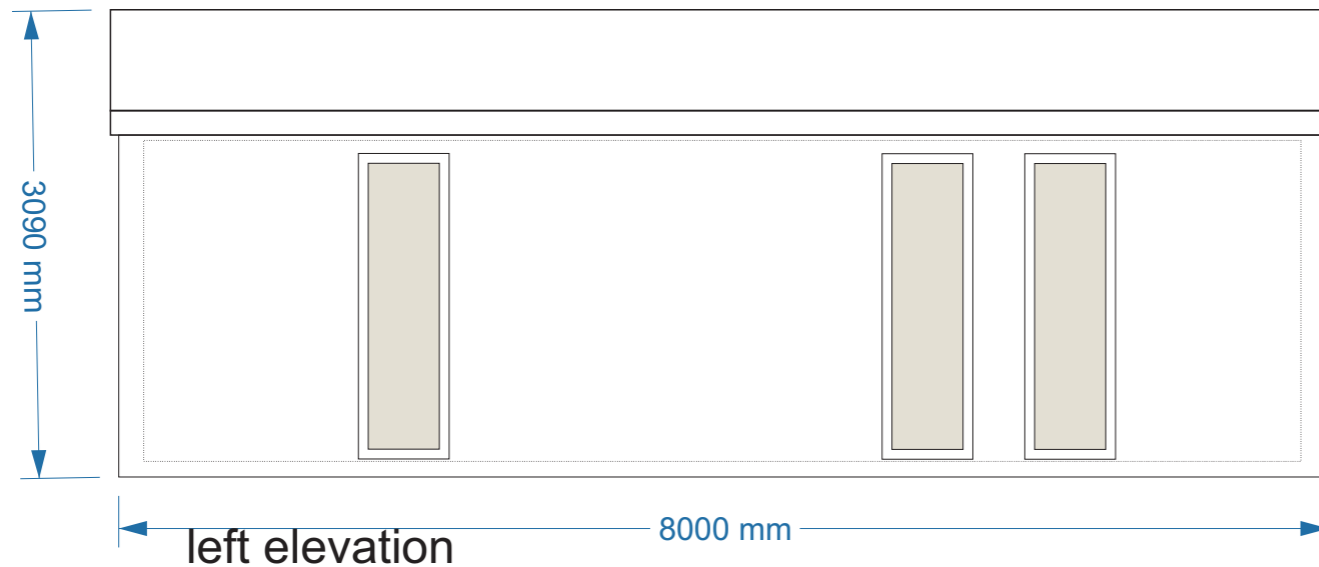

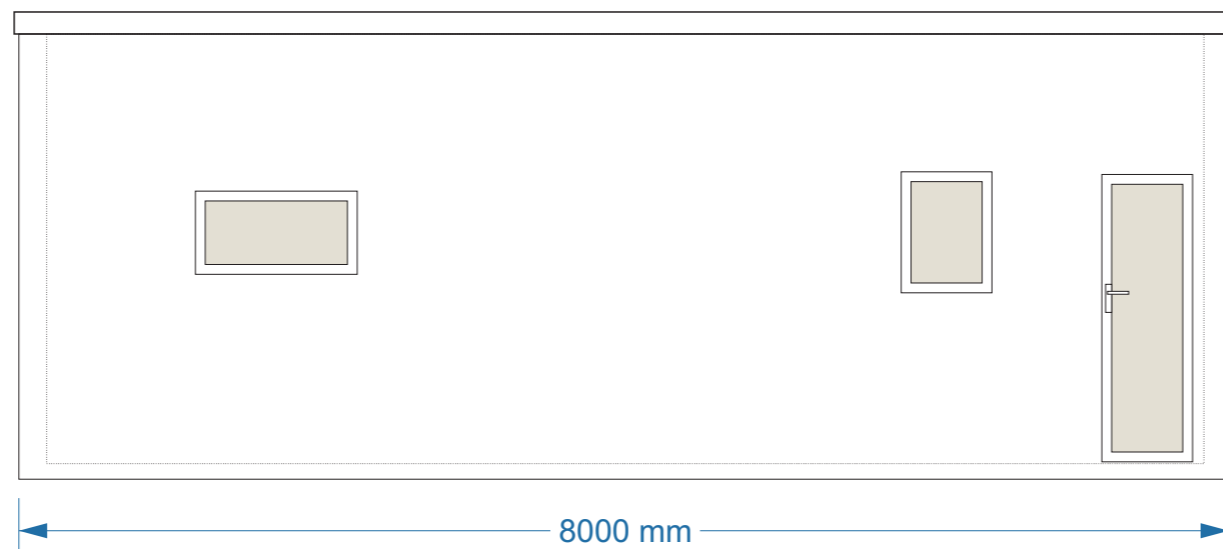
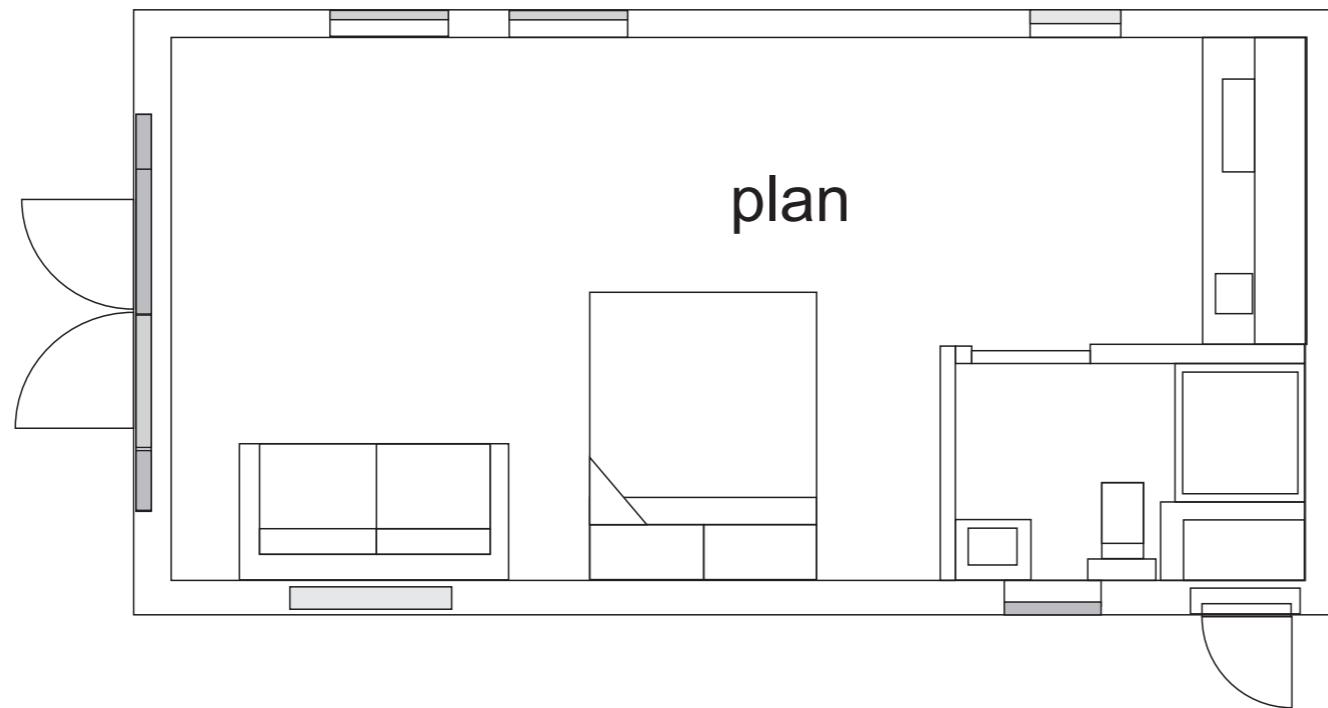

Right elevation

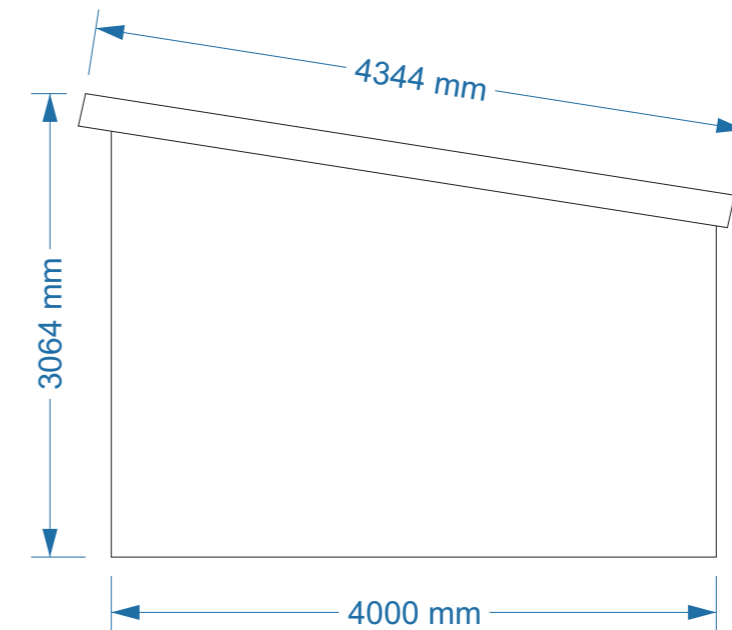

back elevation

double door



rubber roof membrane
epdm

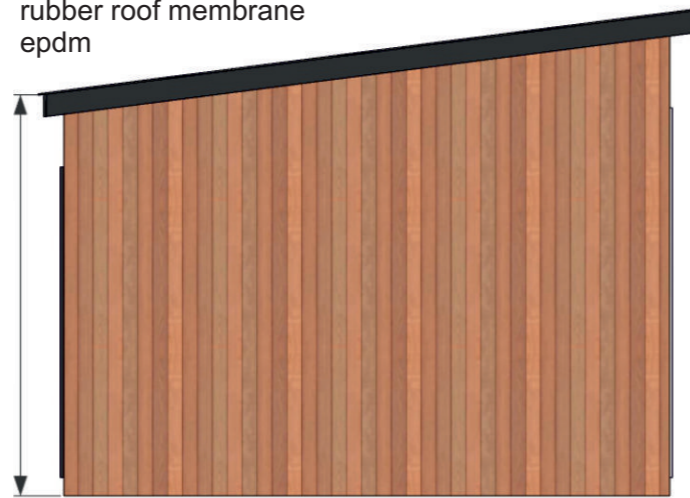

Weston red cedar



plant room door

Stained Cedar
other colour options

bathroom privacy glass