

A - Net swing



General Product Information

Dimensions LxWxH - 420x210x260cm

Age Group - 3-12

Play Capacity (users) - 3

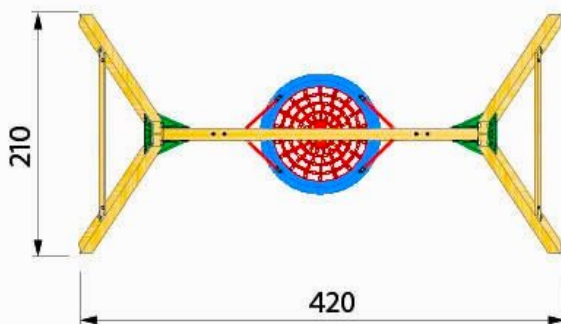

Refer to written dimensions. These are not to scale.

B - Natural Rope 'Jungle' Play



General Product Information

Dimensions LxWxH - 650x650x596cm

Age Group - 6+

Play Capacity (users) - 50

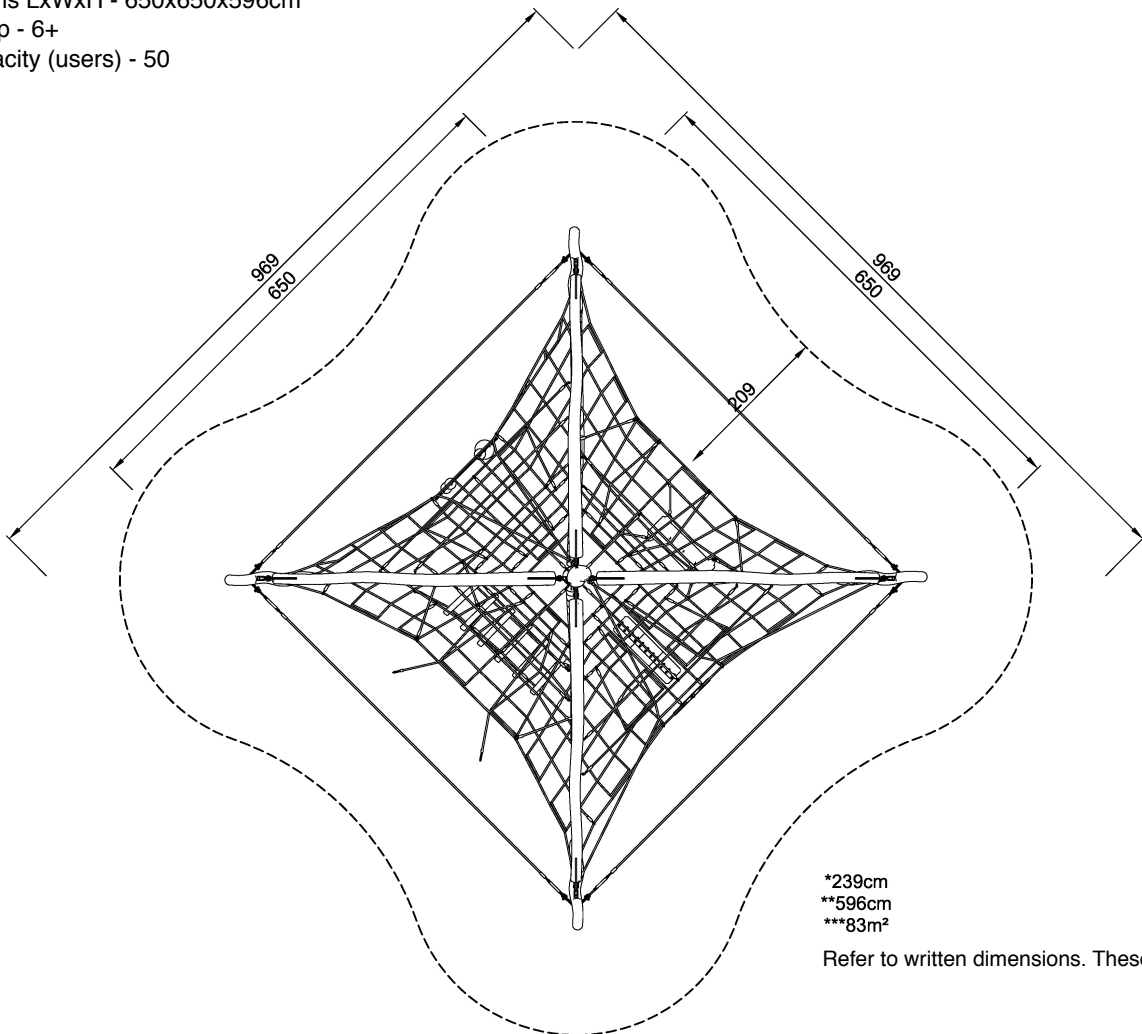

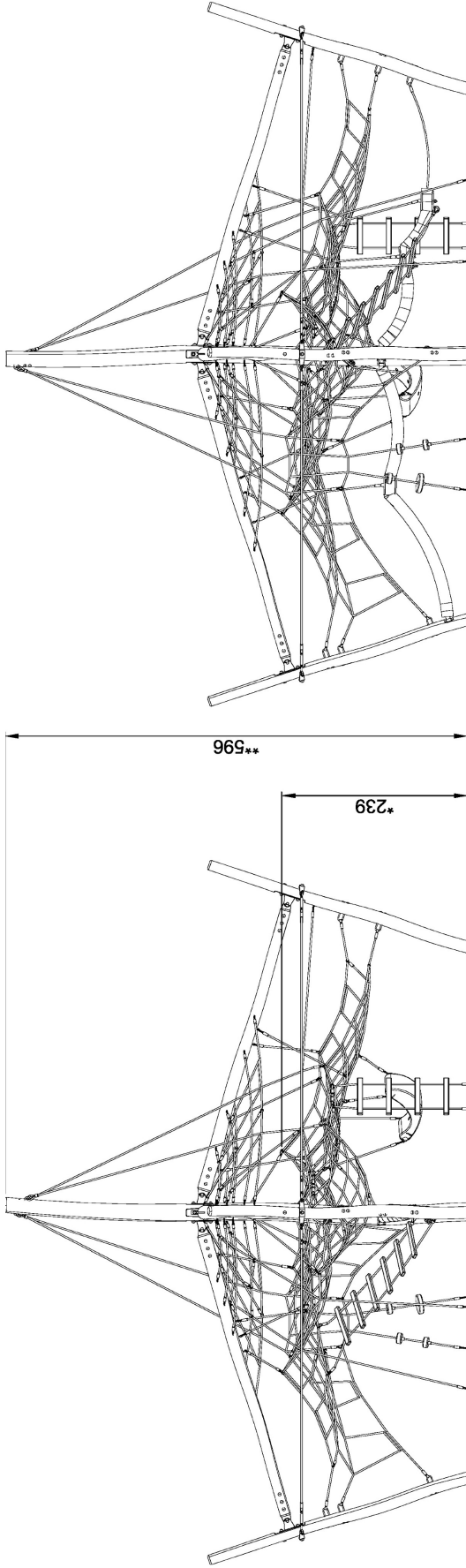

Refer to written dimensions. These are not to scale.

C - High "Castle" assorted play

General Product Information

Overall Dimensions LxWxH - 2195x1478x1040cm

Age Group - 6 - 12

Play Capacity (users) - 50



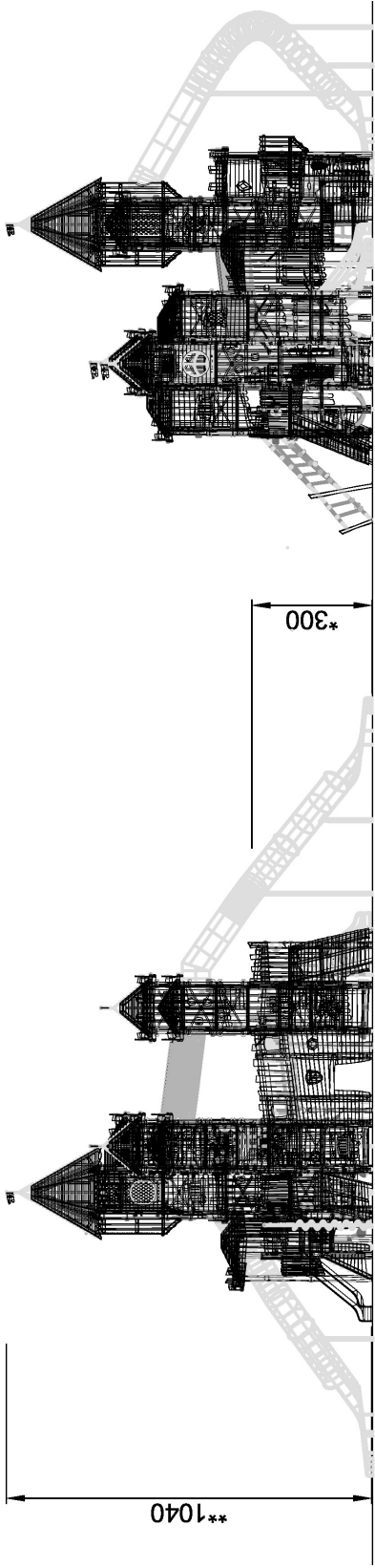

Refer to written dimensions. These are not to scale.

D - "Honeycomb" rope play

General Product Information

Dimensions LxWxH - 2360x1249x910cm

Age Group - 5+

Play Capacity (users) - 110

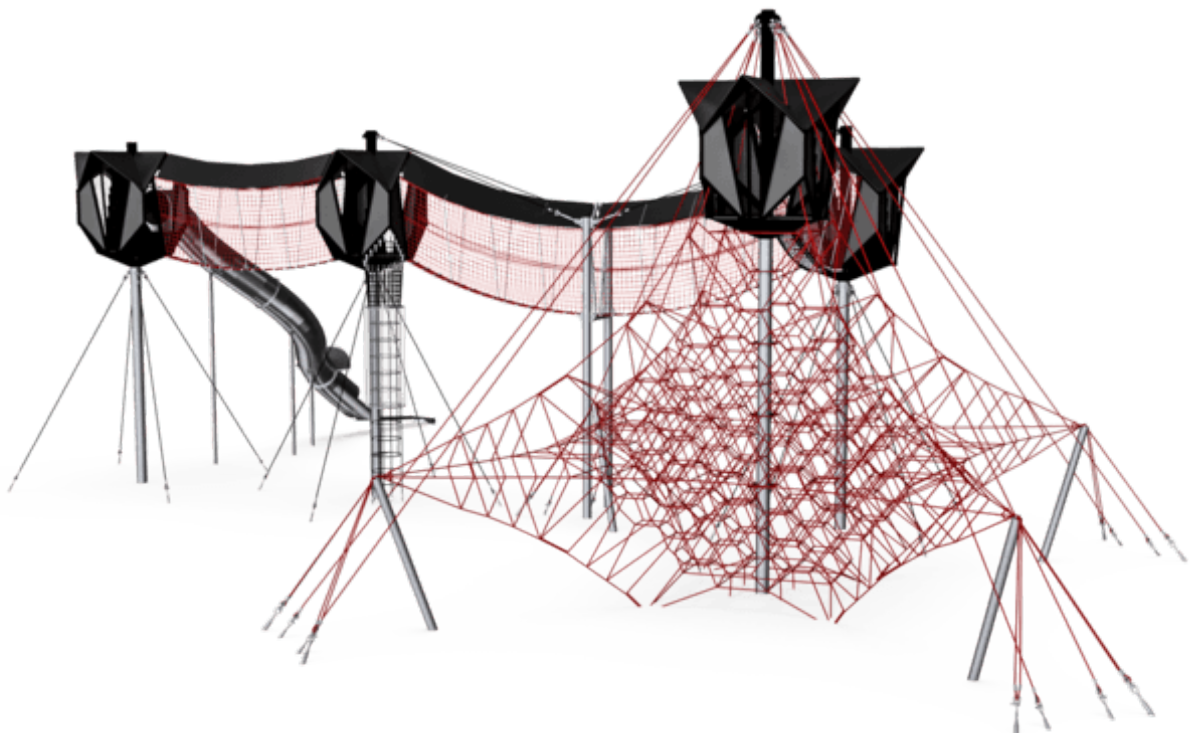
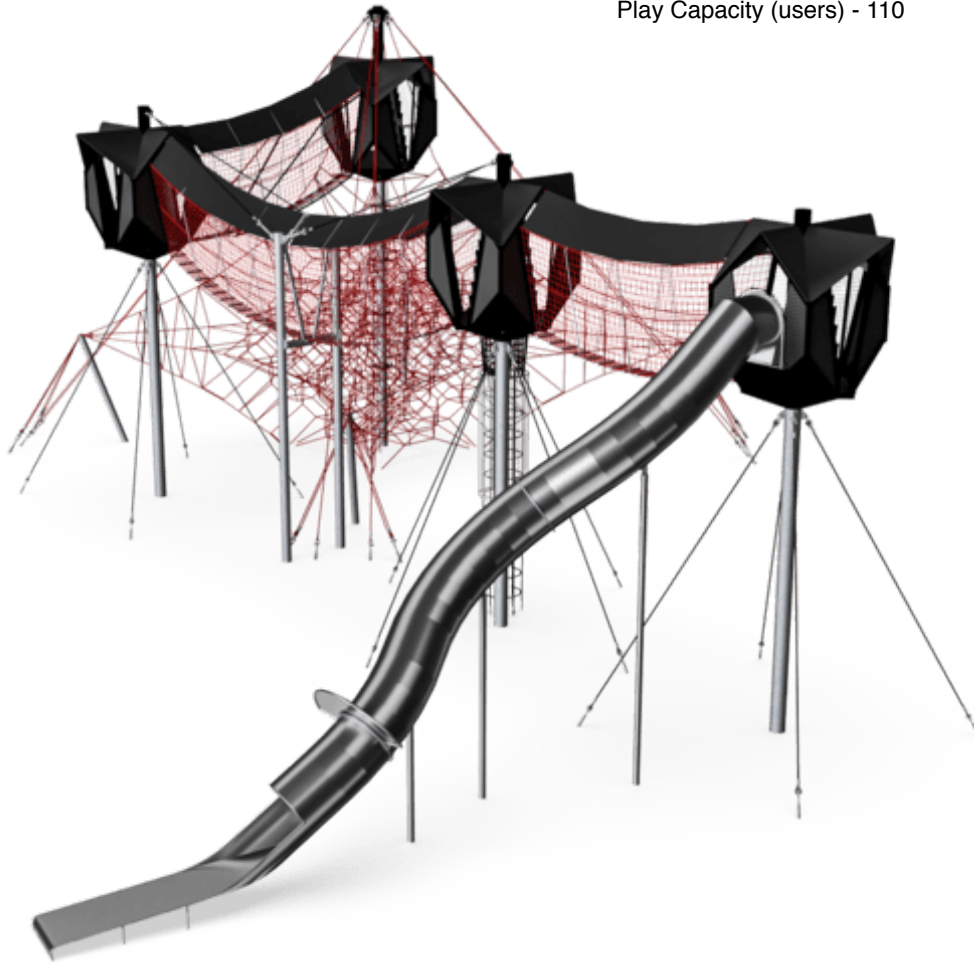

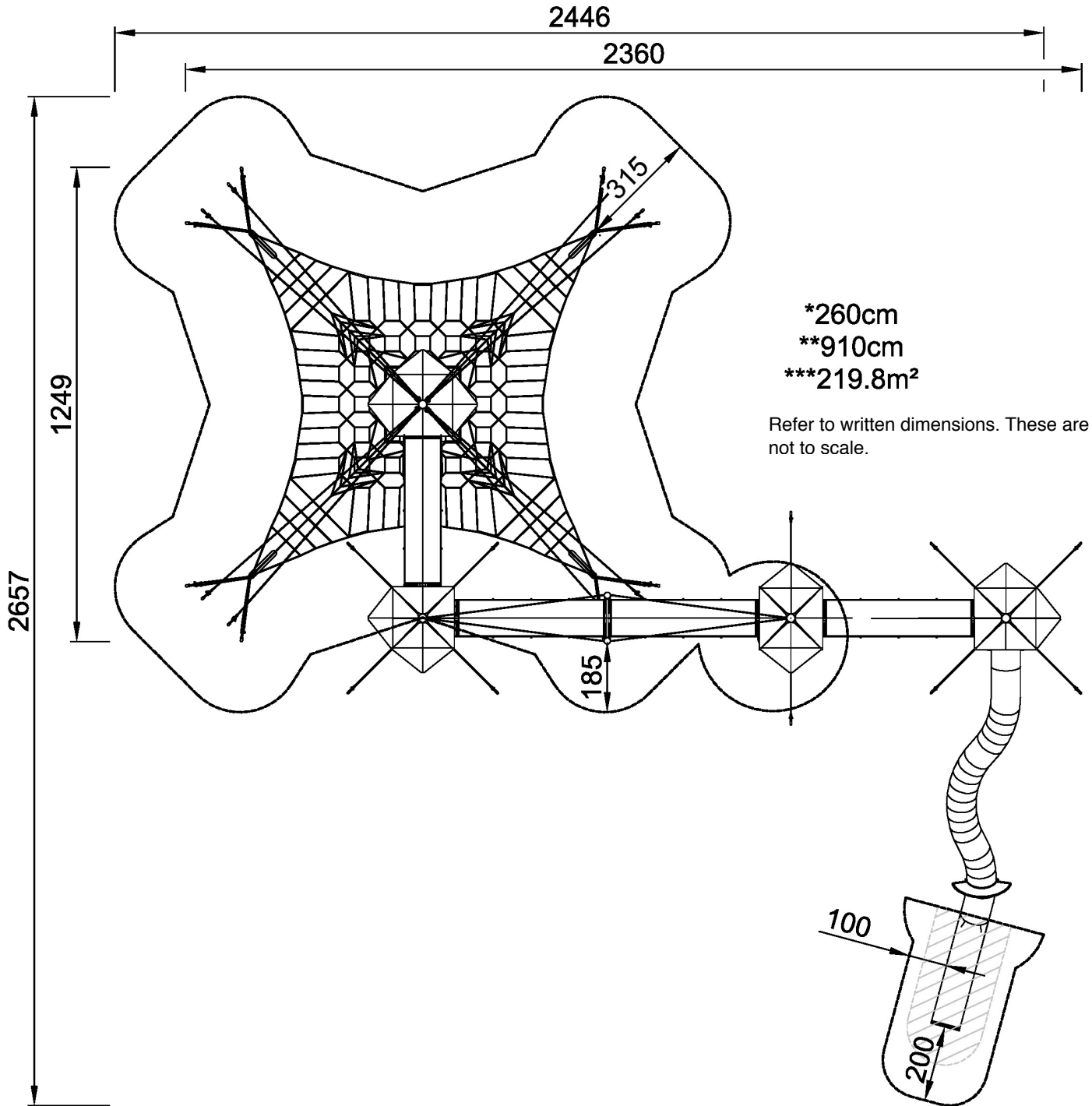

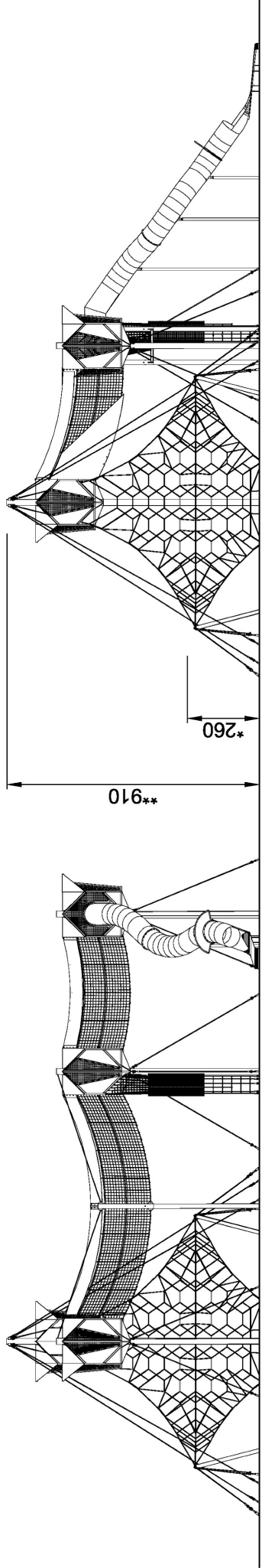

Refer to written dimensions. These are not to scale.

E - Quad Cube Play with slide



General Product Information

Dimensions LxWxH - 1435x660x922cm

Age Group - 5+

Play Capacity (users) - 45

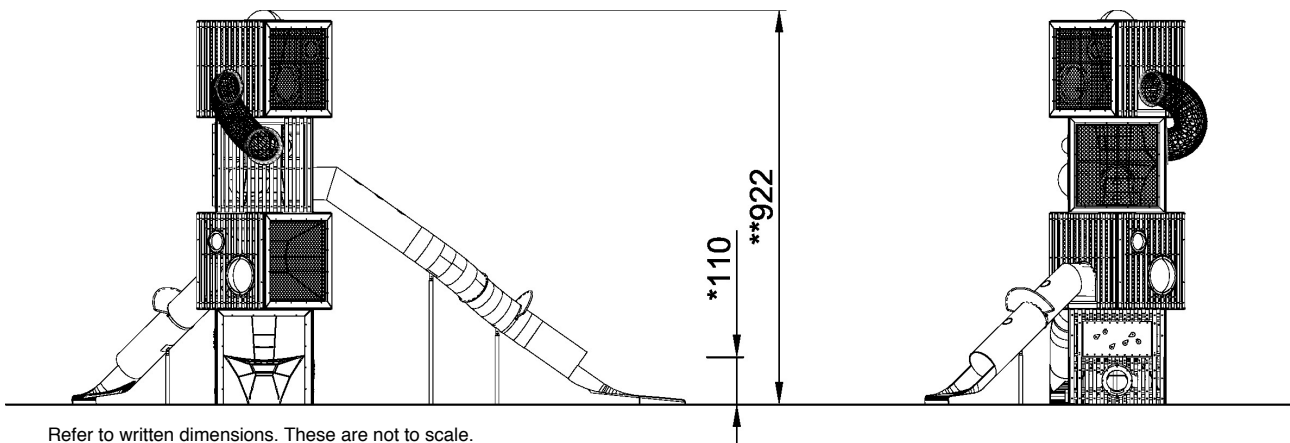

Refer to written dimensions. These are not to scale.

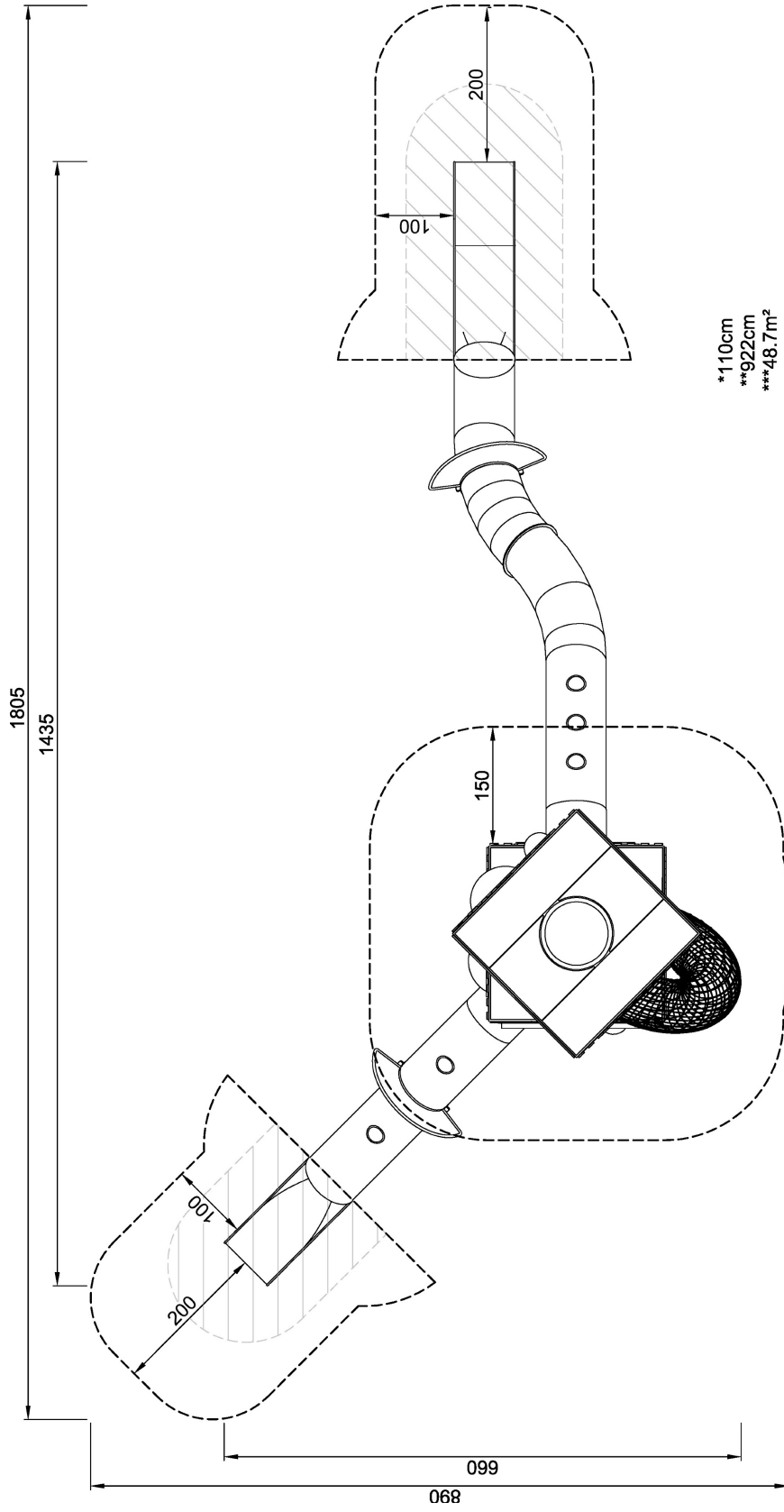

F - 5 seater wooden swing piece

General Product Information

Dimensions LxWxH - 1071x219x290cm
Age Group - 2-15
Play Capacity (users) - 5



Refer to written dimensions. These are not to scale.

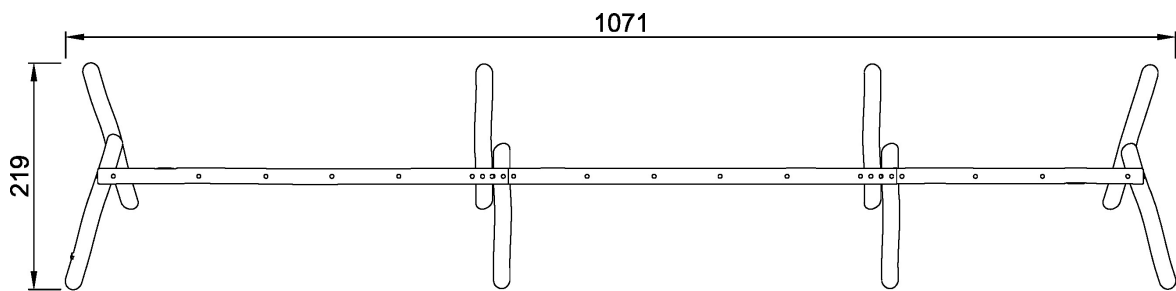

**290cm
***0m²

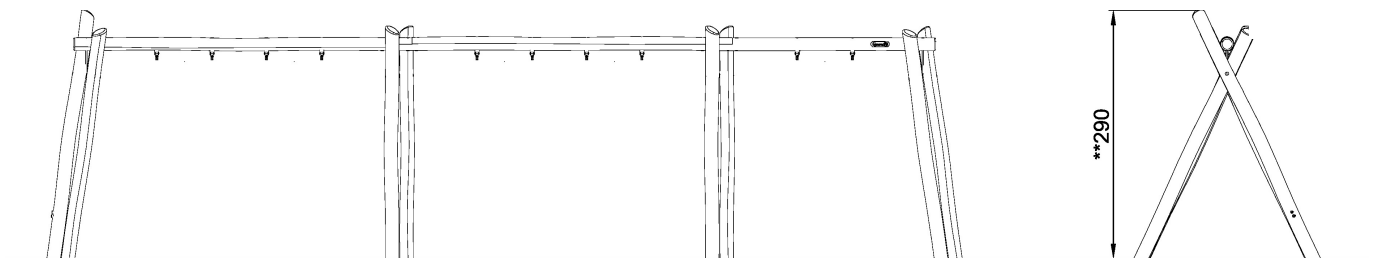

Refer to written dimensions. These are not to scale.

G - "HoneyComb" climbing play

General Product Information

Dimensions LxWxH - 375x213x300cm

Age Group - 3-12

Play Capacity (users) - 16

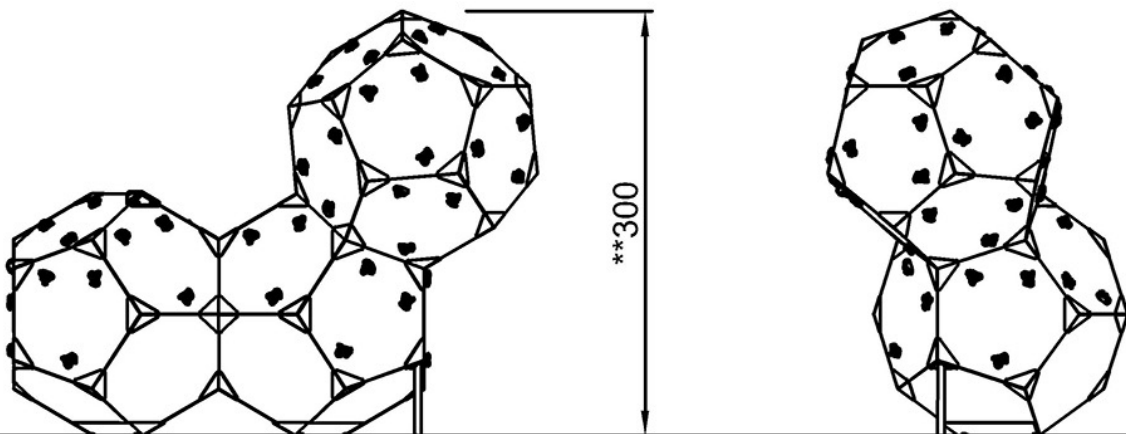
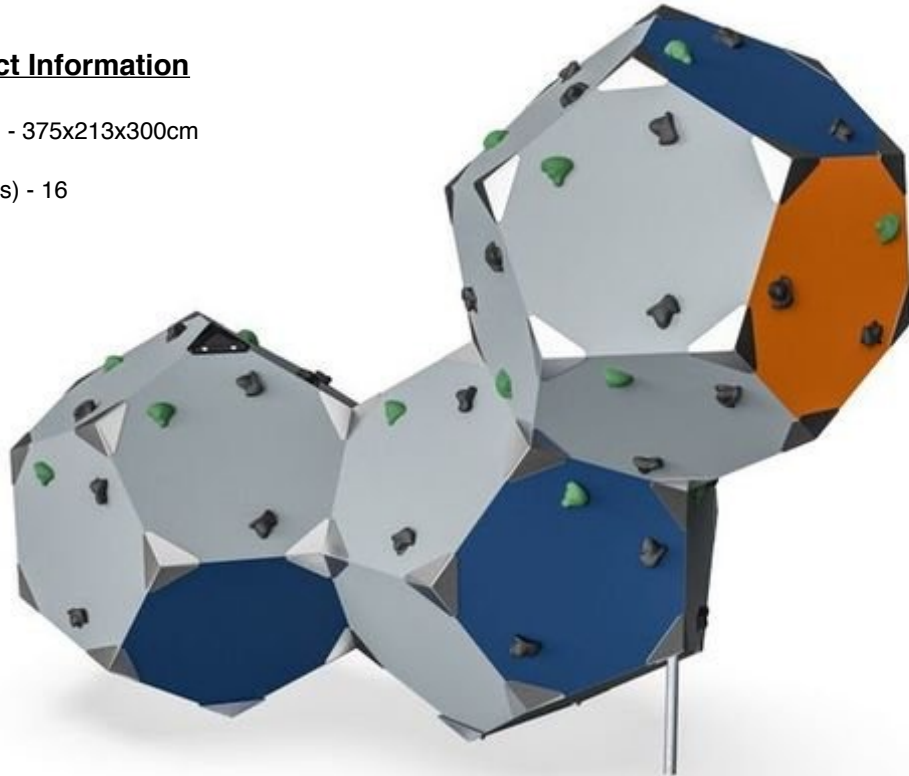

Refer to written dimensions. These are not to scale.

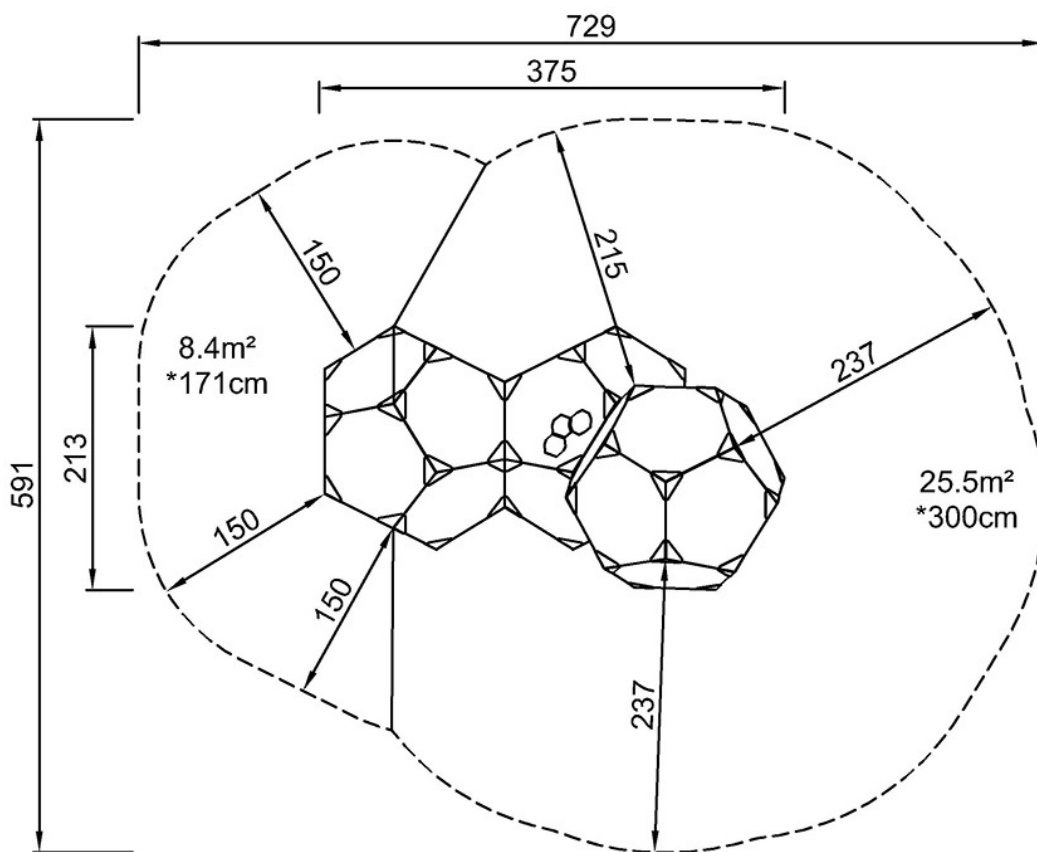

Refer to written dimensions. These are not to scale.

H - Toddler Playhouse climb and slide

General Product Information

Dimensions LxWxH - 454x321x327cm

Age Group - 2+

Play Capacity (users) - 11

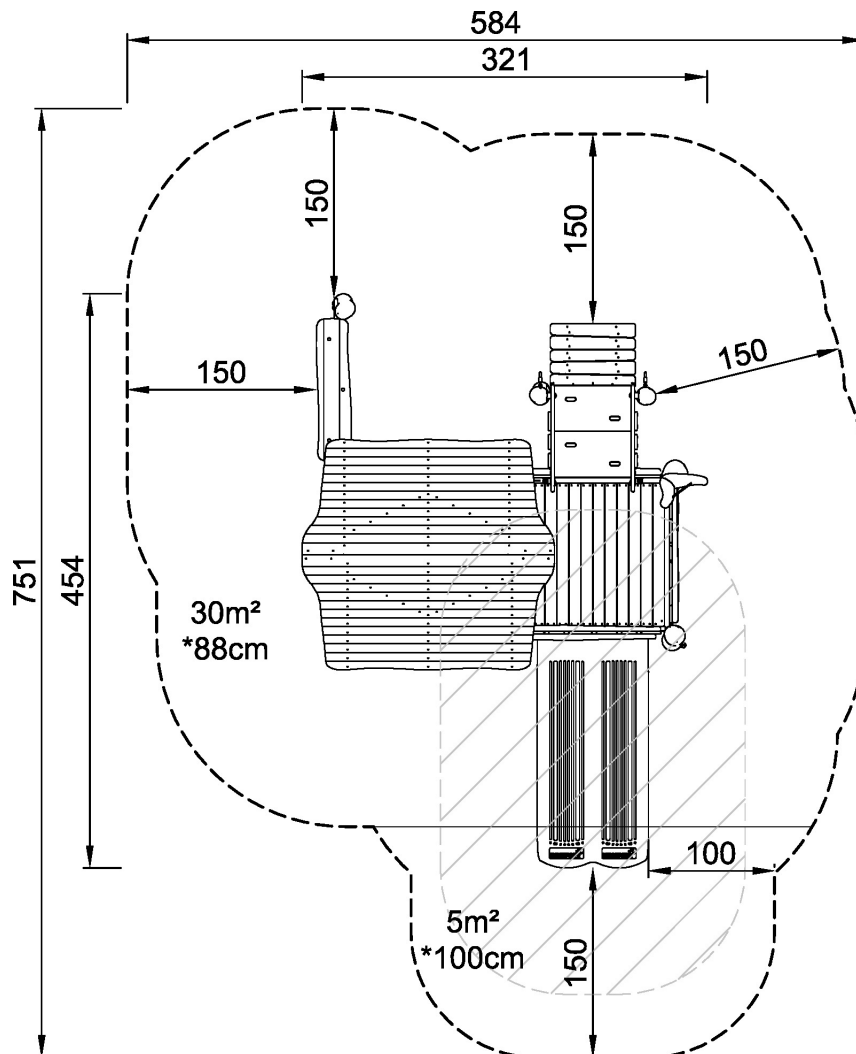

Refer to written dimensions. These are not to scale.

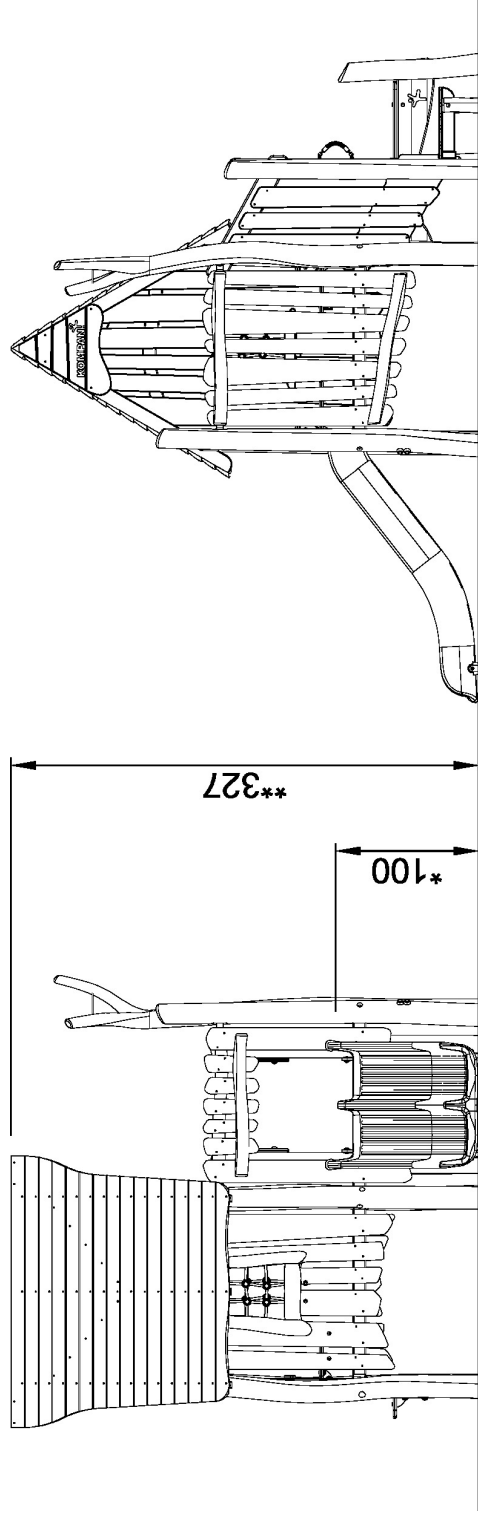

Refer to written dimensions. These are not to scale.

