

2 Existing Side (south) Elevation
1 : 100

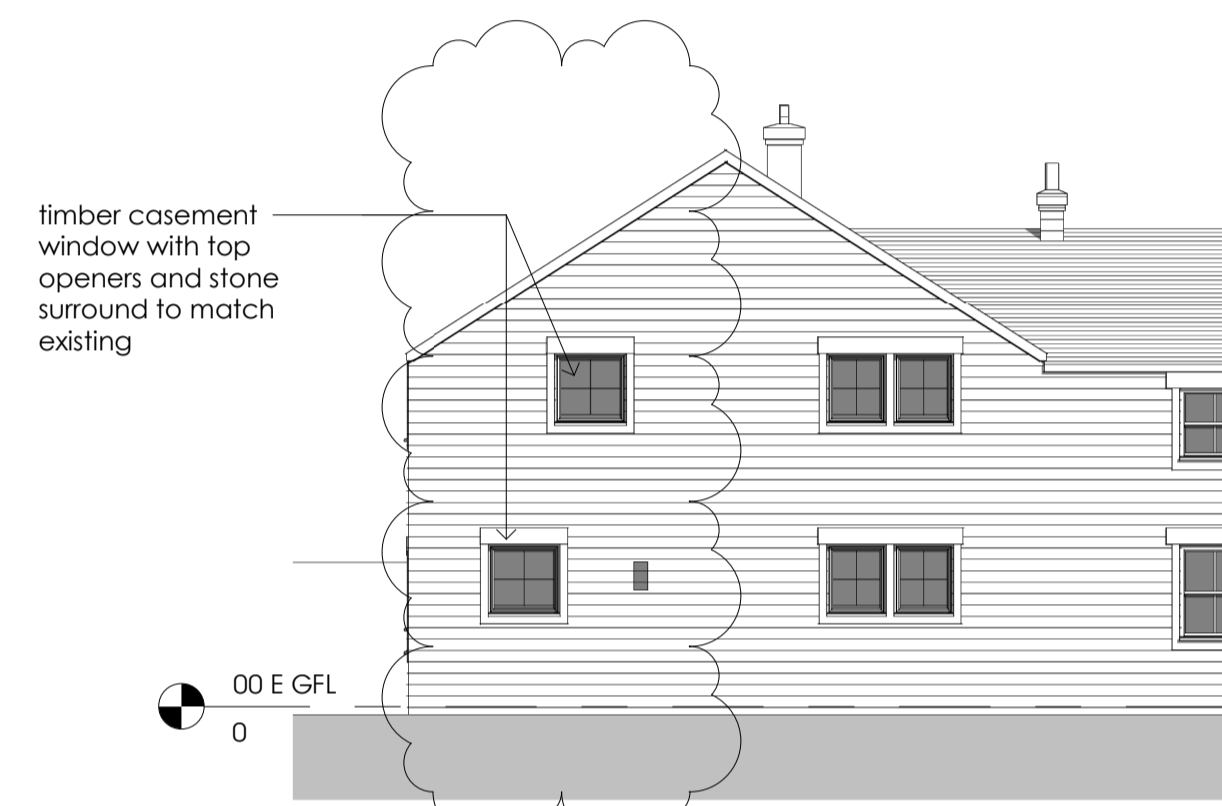

4 Proposed Side (south) Elevation
1 : 100

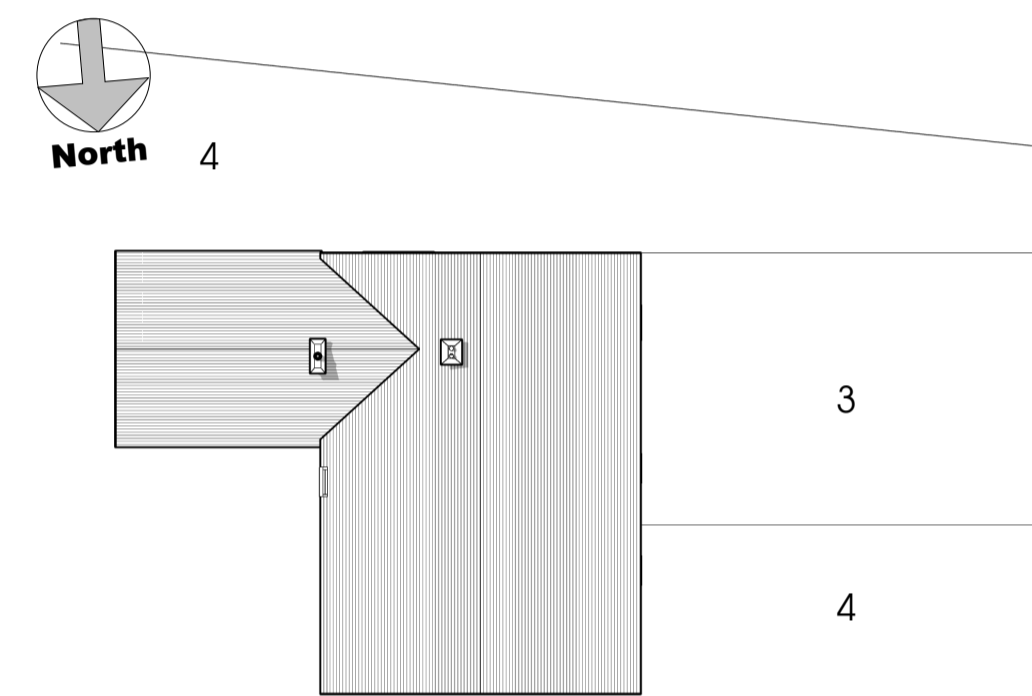

5 Existing Site Plan
1 : 200

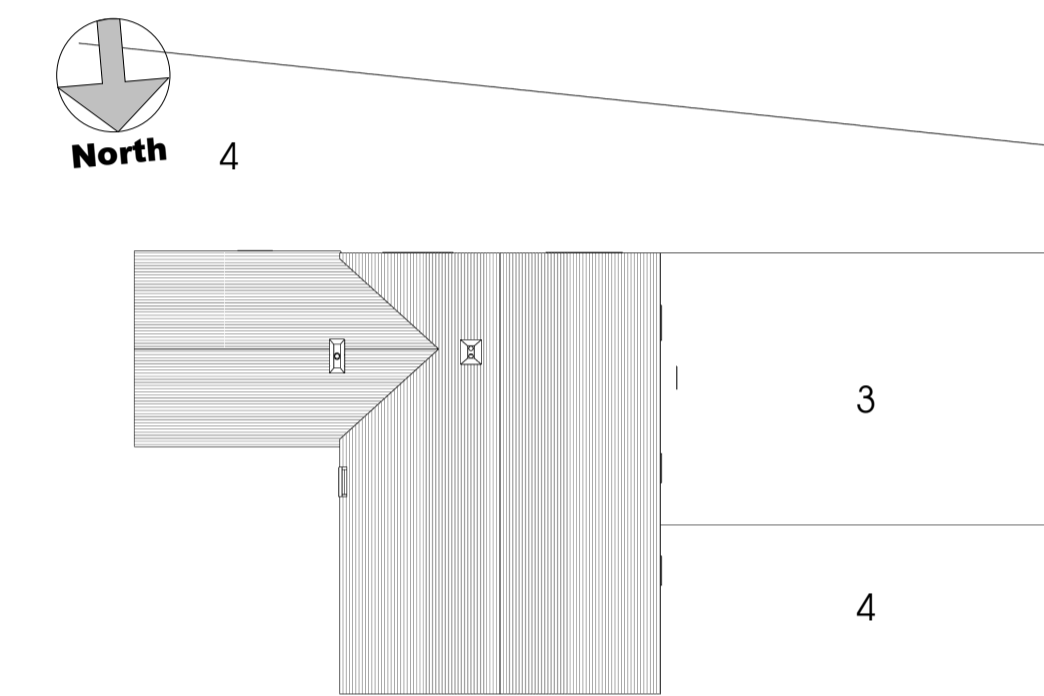

6 Proposed Site Plan
1 : 200

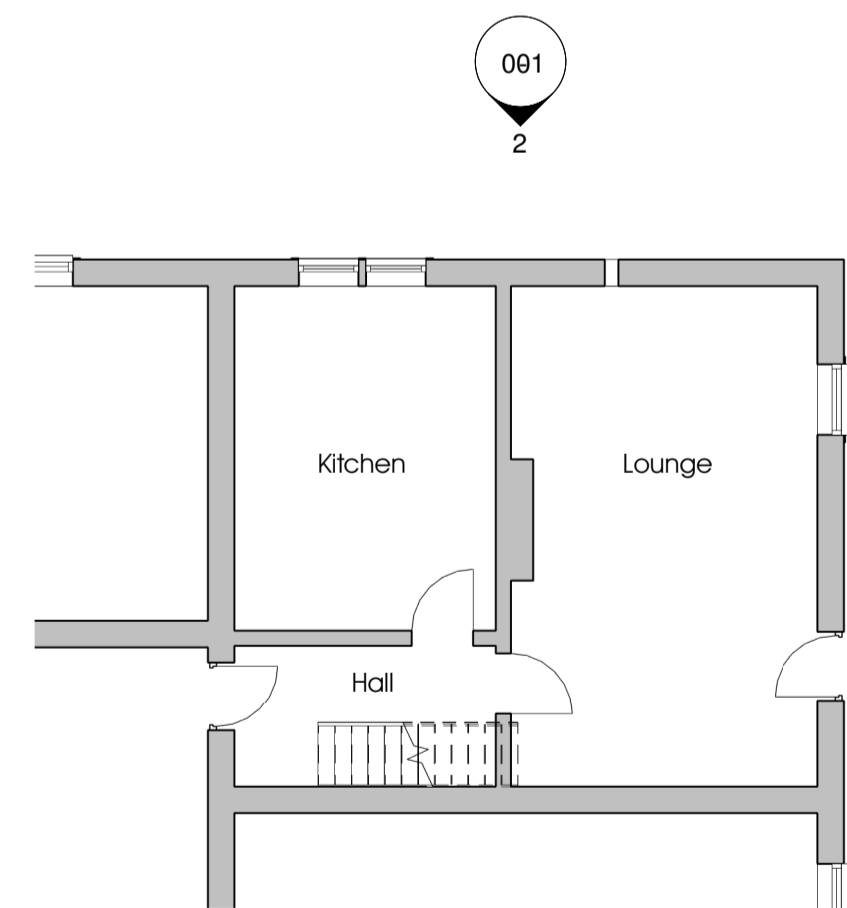

7 Existing Ground Floor Plan
1 : 100

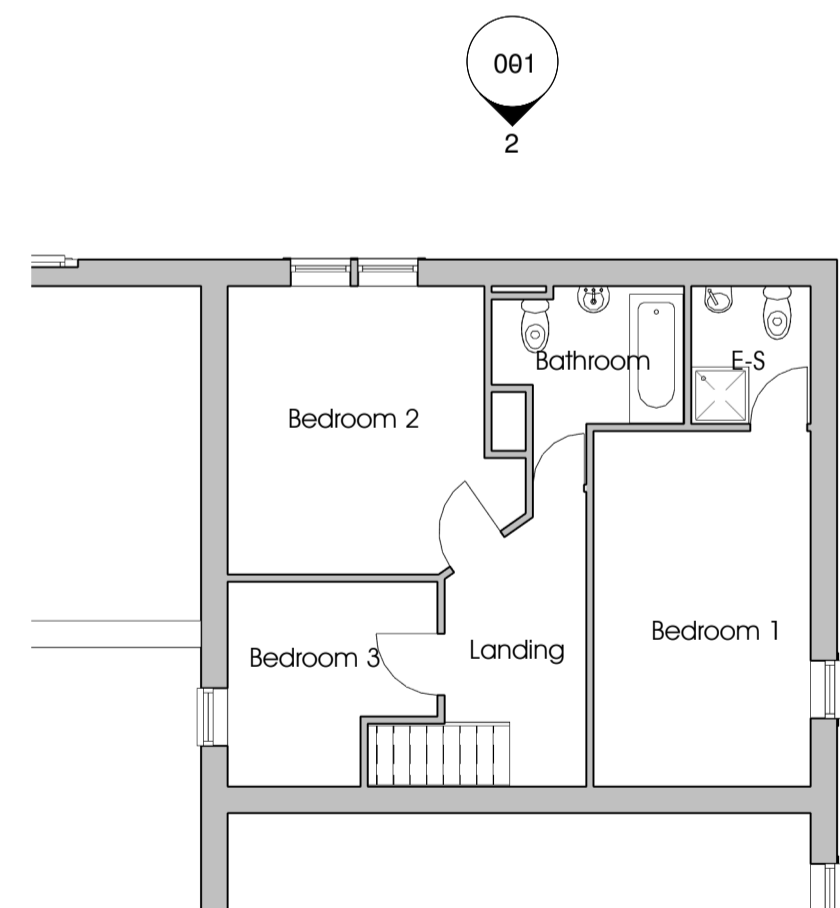

8 Existing First Floor Plan
1 : 100

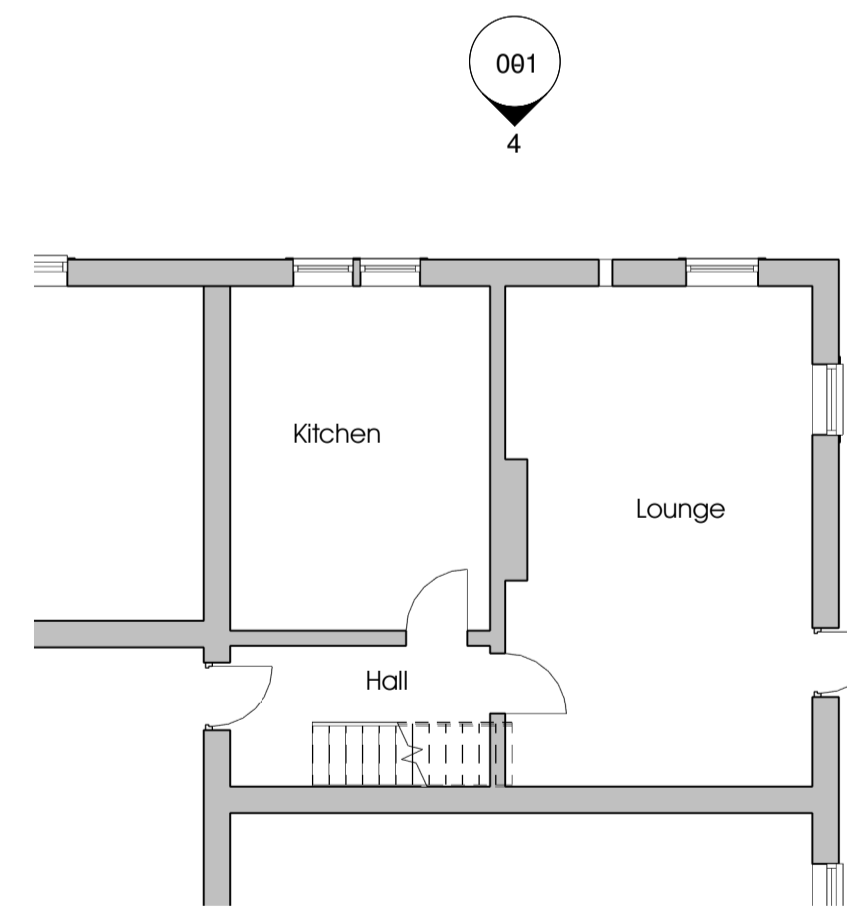

9 Proposed Ground Floor Plan
1 : 100

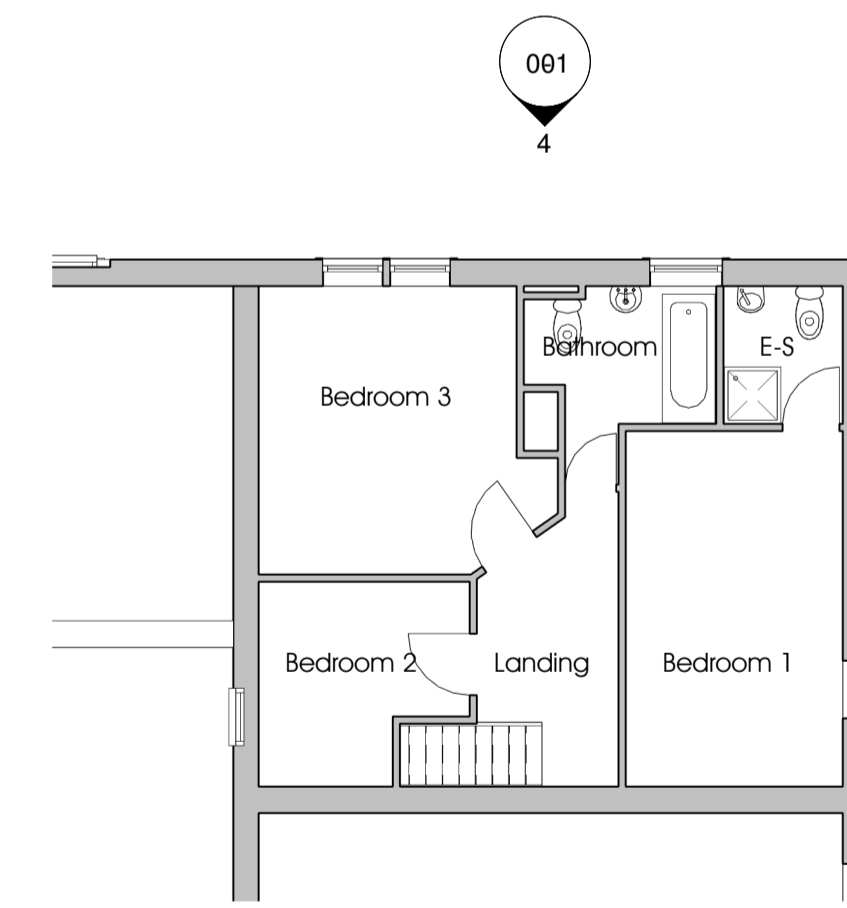

10 Proposed First Floor Plan
1 : 100

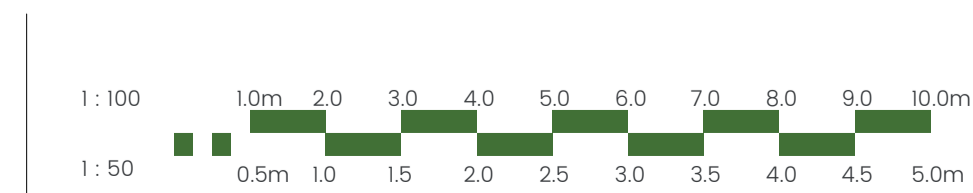

Note:
Do not scale drawing. All dimensions and levels to be checked on site and any discrepancies to be reported immediately before the commencement of work. Drawing to be read in conjunction with all relevant drawings and specifications.



PROJECT NAME & LOCATION 3 Bradley Court, Proposed Side Elevation Alteration	
DRAWING TITLE Existing and Proposed Plans	

PROJECT NO.	DWG NO.	REV.	DRAWN.	CHECK.
AK16	001	B	GW	LB
SCALE. As indicated		@ A1		

UNIT 5 CUNNINGHAM COURT
LIONS DRIVE
SHADSWORTH BUSINESS PARK
BLACKBURN
BB1 2GX
T: +44 (0) 1254 774943
E: INFO@ALDROCK.CO.UK

STATUS: Planning	DATE: 07/11/12
---------------------	-------------------