

HIGHER-ROAD-LONGRIDGE

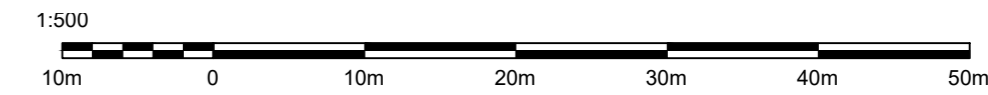

The Copyright of this drawing belongs to MPSL Planning & Design Ltd. and shall not be used or reproduced in any form without its express permission.

Do not scale from this drawing. Work to figured dimensions only. All dimensions to be checked on site prior to execution of any work.

For the avoidance of doubt all dimensions are measured to wall structures and not the finishes unless otherwise stated.

Where any discrepancy is found to exist within or between drawings and/or documents it should be reported to the architect immediately.

MPSL Planning & Design Ltd. shall not be liable for any use of drawings and documents for any purpose other than for which the same were prepared by or on behalf of MPSL Planning & Design Ltd.

Note: Layout to be read in conjunction with the engineers drawings, landscape layout and boundary treatment layout.
Refer to title plan for ownership boundary.
Refer to engineers drawings for retaining wall heights.

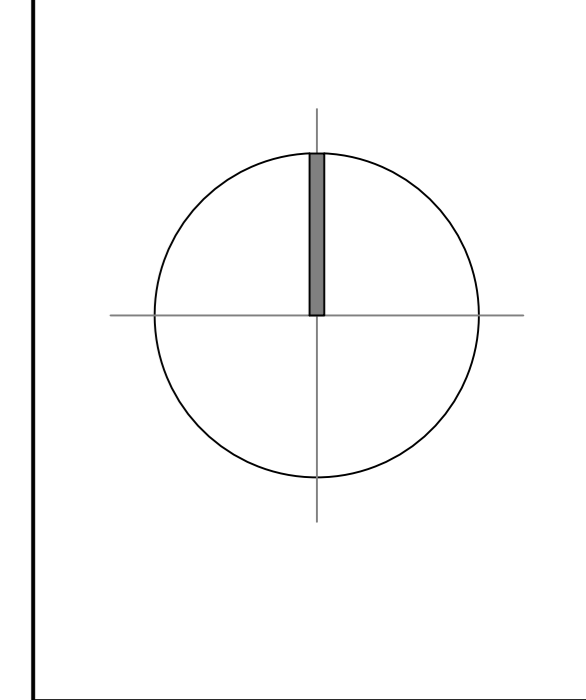

OVER 55'S PROPERTIES

- Denotes over 55's properties, S106 compliant
- Denotes over 55's properties, non S106 compliant

AFFORDABLE ALLOCATION (S106)

- Denotes Affordable Rent
- Denotes Shared Ownership
- Denotes Discounted Market Sale

SURFACE TREATMENTS

- Denotes 5.5m wide spine street with 2.0m wide footway & 3.0m shared cycle route - Black tarmac - Primary
- Denotes 5.5m wide shared access streets with 2.0m wide footways in black tarmac with contrasting stripings - Secondary
- Denotes parking bays and driveways - Black tarmac.
- Denotes 3m wide cycle route - northern side of the primary spine street.
- Denotes proposed traffic calming measure.
- Denotes black paving to raised speed tables.
- Denotes contrasting surface treatment to private driveways.

BOUNDARY TREATMENTS

- Denotes proposed retaining wall positions - Refer to the engineers drawings for heights.
- Denotes 1.8m high brick wall & piers.
- Denotes 1.8m high brick piers & 1.8m close boarded timber panels in between.
- Denotes 1.8m high close boarded timber screen fence.
- Denotes 1.8m high post-and-rail fence.
- Denotes 1.1m high balustrade to rear garden access platform for split level types.
- Denotes 1.1m high railings around play area.
- Denotes 0.6m high brick wall and piers.
- Denotes 0.6m high timber knee rail.
- Denotes lockable gate.

HARD & SOFT LANDSCAPING

- Denotes existing trees to be retained - Refer to TYP for further details.
- Denotes net protection area - Refer to TYP for further details.
- Denotes proposed trees - Refer to the landscape layout for further details.
- Denotes 5m landscape buffer to northern boundary - Refer to landscape layout for further details.
- Denotes proposed hedge planting - Refer to landscape layout for further details.
- Denotes existing trees to be removed - Refer to TYP for further details.

GENERAL

- Denotes refuse bin storage position.
- Denotes property entrance point - refer to engineers drawings for details of Part M compliance.
- Denotes dual aspect house types.
- Denotes properties which feature additional windows to side elevations to address the street.

Rev.	Date	Description	By	Check



Project: PROPOSED-RESIDENTIAL DEVELOPMENT HIGHER-ROAD-LONGRIDGE

Job No: J1401 /TRAFFIC CALMING

Scale: 1:500

Date: APRIL 2022

Drawn: AD

Checked: PLANNING

