

**REPAIR DETAIL 1**  
**TYPICAL SECTION THROUGH FAILED FLOOR BEAM 1**

1:10

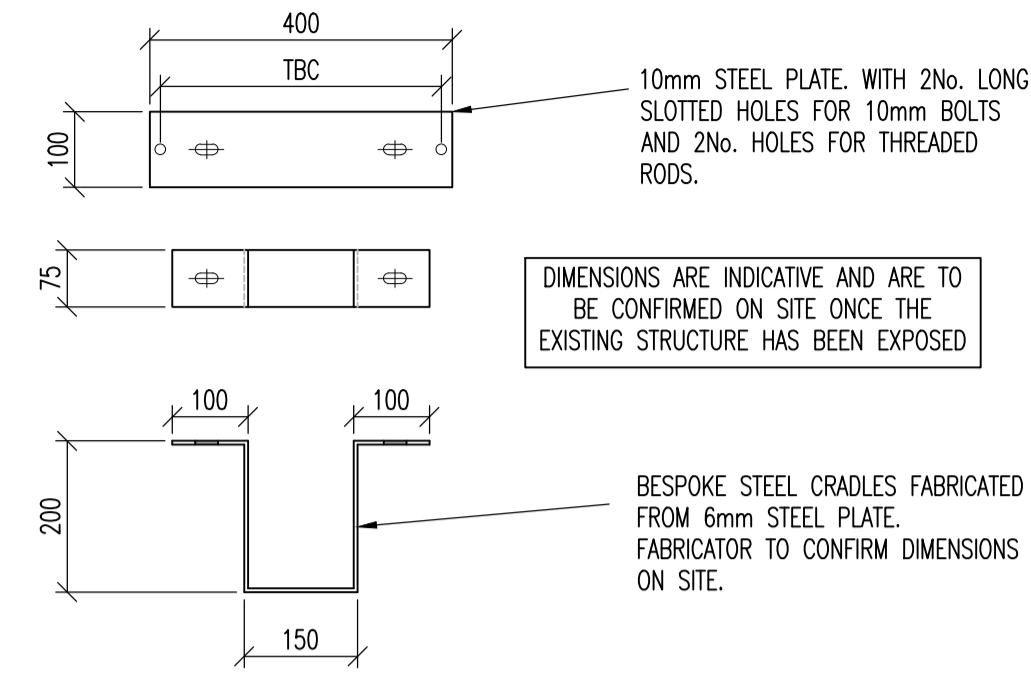

**REPAIR DETAIL 1**  
**CRADLE DETAILS**

1:10

**BEAM 1 REPAIR METHOD STATEMENT**

1. ENSURE ALL ACROW PROPS ARE SECURE BENEATH THE BEAM.
2. REMOVE BATHROOM FITTINGS AND WATER TANK WITH ASSOCIATED PIPEWORK AND CASING IN BEDROOM 3.
3. ADJUST AIRING CUPBOARD DOOR AND SURROUND TO ALLOW INSERTION OF PFC.
4. CREATE HOLE IN PARTITION BETWEEN BEDROOM 3 AND LANDING TO ALLOW INSERTION OF PFC.
5. CREATE HOLES IN THE REAR WALL TO ENABLE INSERTION OF PFC'S.
6. CAREFULLY REMOVE AND SET ASIDE FOR RE-USE APPROXIMATELY 250mm WIDE STRIP OF FLOOR BOARDS AND BATTENS/BOARDS USED TO BUILD UP FLOOR LEVELS IN BATHROOM ADJACENT TO BATHROOM/BEDROOM 3 PARTITION.
7. CAREFULLY REMOVE AND SET ASIDE FOR RE-USE FLOOR BOARDS ADJACENT TO THE PARTITION WALL IN BEDROOM 3.
8. CAREFULLY REMOVE STRIPS OF PLASTERBOARD TO LOUNGE CEILING EITHER SIDE OF BEAM 1.
9. ASSESS PROPOSED POSITION OF PFC BEAMS TO ENSURE THAT THE WATTLE AND DAUB PARTITION IS NOT DISTURBED AND THAT THERE IS SUFFICIENT CLEARANCE AT THE DOORWAY INTO THE BATHROOM.
10. ASSESS POSITIONS OF LOAD-BEARING WALLS AT PROPOSED PFC BEARINGS. DEPENDENT ON POSITION OF BEAMS IN RELATION TO THE LOAD BEARING WALLS, INSERT EITHER CONCRETE PADSTONES AT BEAM BEARINGS ON MASONRY WALLS OR PROVIDE STEEL POST TO SUPPORT BEAM.
11. EVALUATE POSITION OF EXISTING FLOOR JOISTS AND TIMBER TRIMMER BEAMS WITHIN THE EXISTING FLOOR STRUCTURE AND ASSESS POSITIONS FOR NEW STEEL CRADLES. CRADLES TO BE AT MAXIMUM 500mm CENTRES.
12. ENGINEER TO CONFIRM CRADLE POSITIONS.
13. FABRICATOR TO CAREFULLY CHECK DIMENSIONS AND PRODUCE CRADLES/HANGERS.
14. INSERT NEW PFC BEAMS THROUGH OPENINGS IN REAR WALL AND SEAT ON PADSTONES/SUPPORTS. THE PFC'S ARE TO BE POSITIONED ADJACENT TO THE WATTLE AND DAUB PARTITION AND ARE NOT TO DISTURB THE FINISHES TO THE PARTITION.
15. OFFER UP HANGERS AND FIX TO PFC'S USING ADJUSTABLE TENSION RODS AS INDICATED ON DETAIL 1.
16. REPLACE TIMBER PACKS AND FLOOR BOARDS AT FIRST FLOOR.
17. REPAIR PLASTERBOARD CEILING IN LOUNGE.

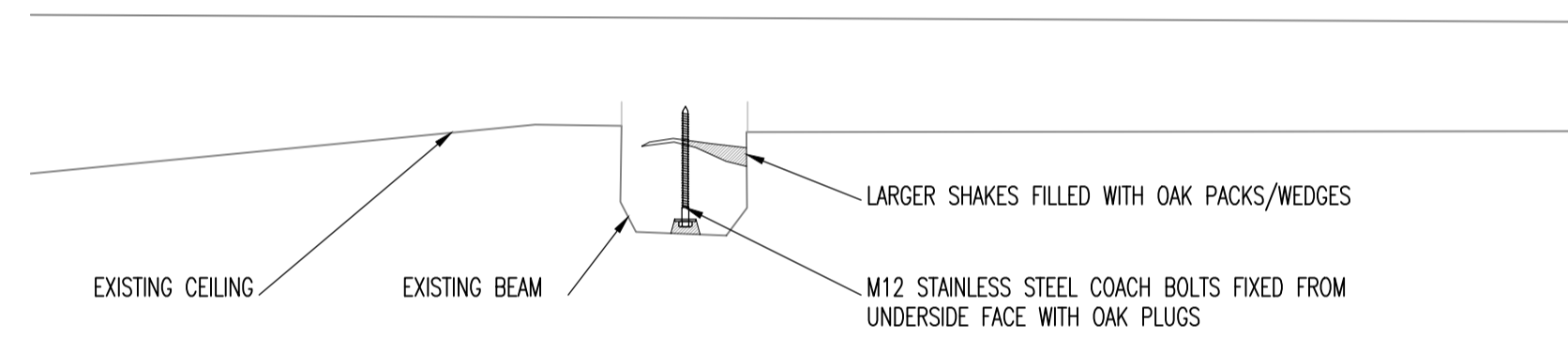

**DETAIL 2**  
**TYPICAL SECTION THROUGH FLOOR BEAM 2**

1:10

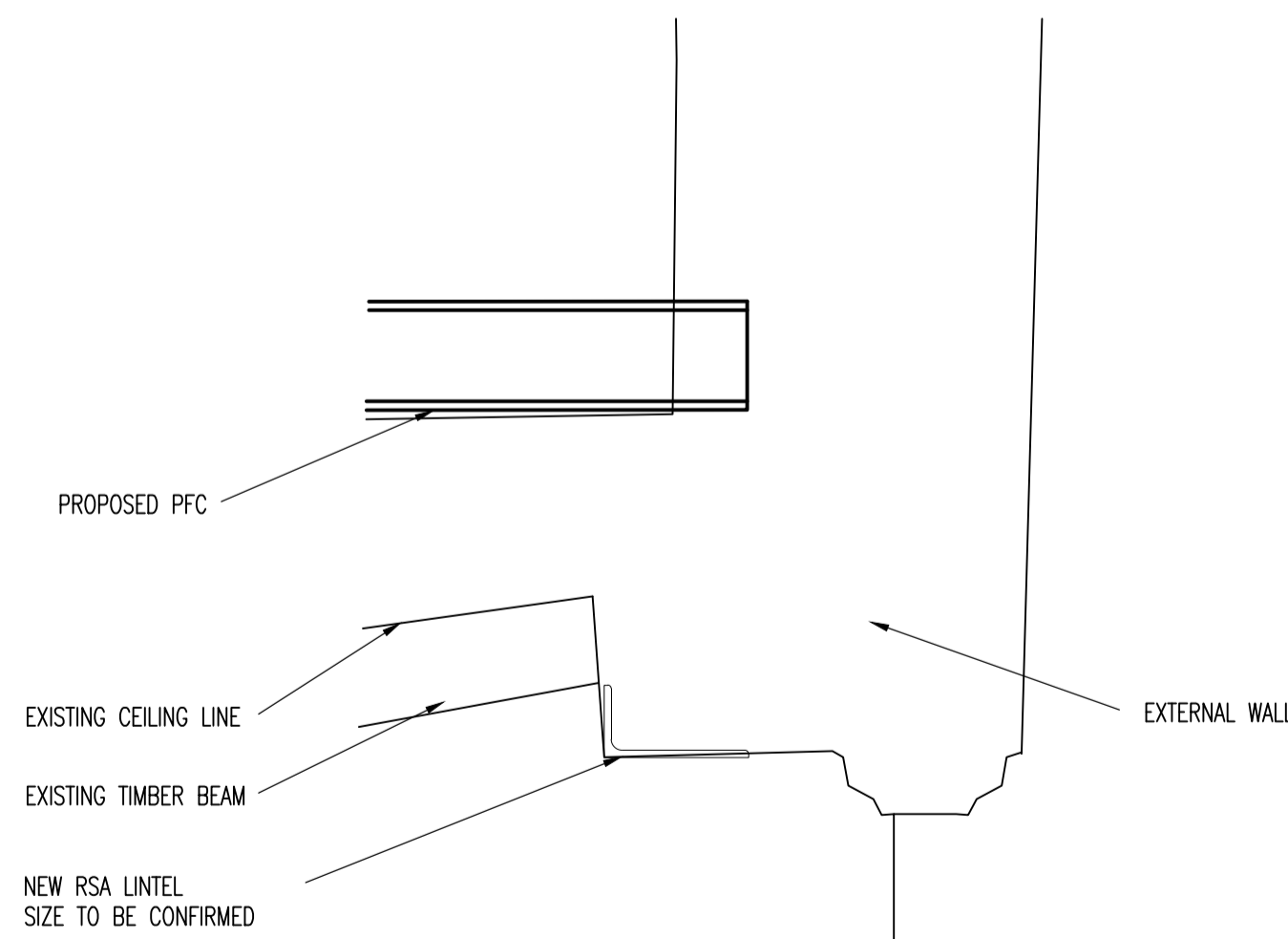

**DETAIL 3**  
**SECTION THROUGH BEAM 1 BEARING OVER REAR WINDOW**

1:10

**LINTEL STRENGTHENING METHOD STATEMENT**

1. PRIOR TO INSERTING PFC CHANNELS THE CONDITION OF THE LINTELS OVER THE REAR LOUNGE WINDOW AND THE CENTRAL PIER IS TO BE ASSESSED.
2. CAREFULLY REMOVE PLASTER FINISHES TO THE AREA OF PLASTER WHICH IS CRACKED ABOVE THE CENTRAL PIER.
3. ENGINEER TO ASSESS EXISTING LINTELS, BEARINGS AND CENTRAL PIER.
4. IF STRENGTHENING IS DEEMED NECESSARY, REMOVE THE PLASTER FINISHES ALONG THE LENGTH OF THE WINDOW OPENING AND INSERT NEW RSA BENEATH EXISTING LINTELS/MASONRY. REFER TO DETAIL 3.
5. ENSURE THE RSA EXTENDS INTO THE EXISTING MASONRY AT BEARINGS.
6. REBUILD CRACKED MASONRY TO CENTRAL PIER USING LIKE FOR LIKE STONE AND LIME MORTAR.

P1	ISSUED FOR APPROVAL	JED	LR	11.06.21
Rev	Details	Drawn By	Chk/App By	Date

Client:  
**THE BRABIN TRUST**

Project:  
**1ST FLR REMEDIAL WORKS  
BRABIN'S HOUSE  
CHIPPING**

Title:  
**REPAIR DETAILS**

Issued For:  
**APPROVAL**

**Reid Jones partnership**  
Consulting Civil & Structural Engineers

9 Orrell Road, Wigan, WNG 5EY, Tel 01942 216006  
3 Cross Street, Preston, PR1 3LT, Tel 01772 498007

E-mail: eng@reidjonespartnership.co.uk  
Web address: www.reidjonespartnership.co.uk

Scale:	1:50	@	(A1)
Project No:	10139	Drawing No:	03
		Issue:	P1

**PRELIMINARY DRAWING.  
NOT FOR CONSTRUCTION.**

DO NOT SCALE - USE FIGURED DIMENSIONS ONLY.  
This drawing is confidential and is the property of Reid Jones Partnership. It must not be disclosed to any third party, copied or lent without prior written consent. The contractor is to check all dimensions on site prior to commencement of works.

**QMS**  
ISO 9001:2015  
REGISTERED