

SIDE ELEVATION

FRONT ELEVATION

REAR ELEVATION

SIDE ELEVATION

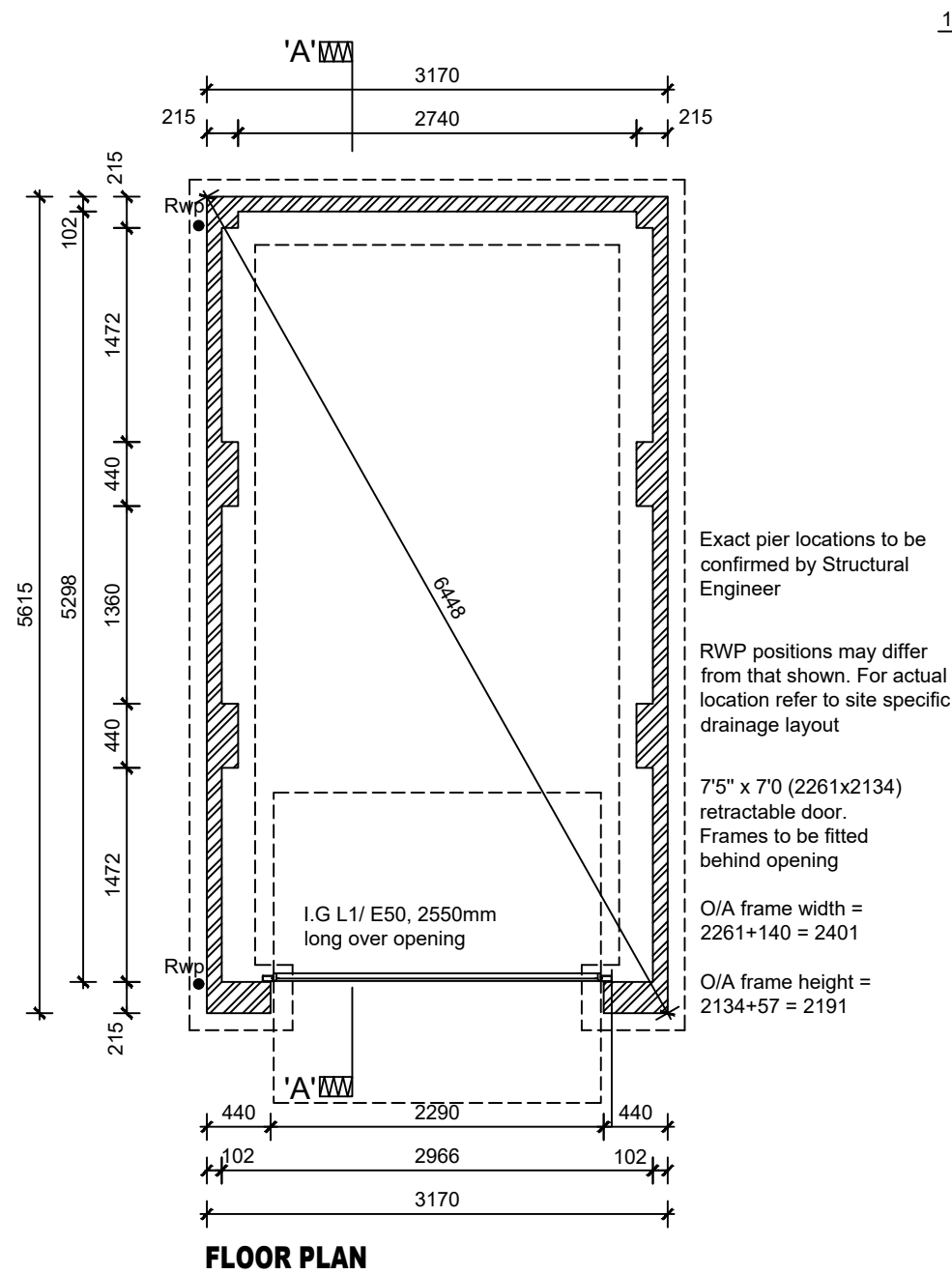

FLOOR PLAN

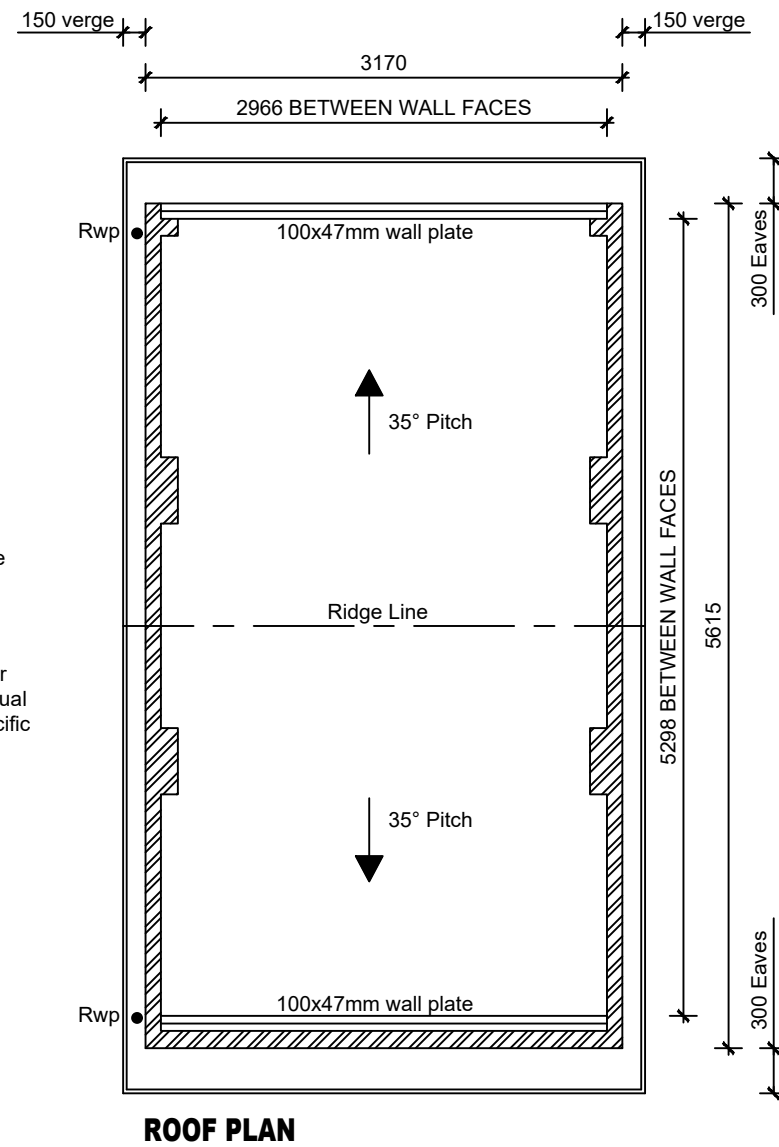

ROOF PLAN

NOTES:

- Roof pitch 35°
- Read in conjunction with Standard Specification
- Refer to truss manufacturers drawings for truss profiles and sizes of timber sections.
- Roof trusses to be designed and fabricated by specialist in accordance with BS:5268:Part3:2006 with spacing at max. 600mm ctrs. Roof plan to specialist design with calculations and full bracing details submitted prior to work.
- Longitudinal bracing and diagonal rafter and ceiling bracing to be 25x100mm basic section and fixed in accordance with BS:5268:Part3:2006 and NHBC requirements. Fixing to be 75x3.35mm galv. round wire nails to each trussed rafter member.

WALL KEY:

Reconstituted Stone (Ext Walls - Ext Leaf)

Barratt Homes (Manchester Division)
 4 Brindley Road
 City Park
 Manchester
 M16 9HQ

Tel: 0161 872 0161
 Fax: 0161 855 2828

Garage Code

2010 Range - Garage Drawing		Single Detached Garage - Classic Stone	
Date	Feb 2013	2010/DET/CS/01	Scale
Drawn by	SAH		
Checked by			
Revision		1:50 / 1:100 @ A3	

WARNING TO HOUSE-PURCHASERS. Property Misdescriptions Act 1991
 Buyers are warned that this is a working drawing and the contents of this drawing may be subject to change at any time and alterations and variations can occur during the progress of the build process. As such the layout, form, content and dimensions of the finished construction may differ materially from those shown. Whilst we make every effort to ensure our drawings are up to date there may from time to time be an unavoidable delay in updating these due to changes in regulations and/or re-planning. Purchasers are advised to check with the Sales Adviser whether any alterations have been made to this drawing. The contents of this drawing do not constitute a contract, part of any contract or warranty.