

ACCESS ROAD SECTION A - B OWNER MR ASHLEY MARTIN
 ACCESS ROAD SECTION B - C OWNER MR HARRY ROPER
 ACCESS ROAD SECTION C - D OWNER CHURCH COMMISSIONERS

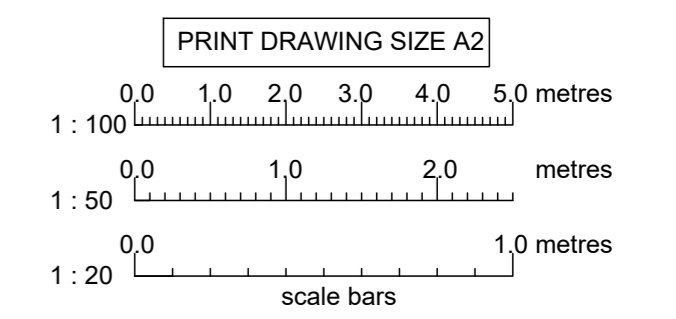

- NOTES :**
- DO NOT SCALE FROM THIS DRAWING. Check dimensions on site or refer to Architect/Engineer. IF IN DOUBT - ASK. If this Drawing is printed or reproduced in any format, scales may differ significantly from those shown.
 - This Drawing to be read in conjunction with : Architect Drawings No. RSCE Drawings No. manufacturers instructions and specifications and current European and British Standards and Codes of Practice
 - Structural Steelwork grade S275
 Fabricated Steelwork to BS EN1090 Execution Class EXC2
 Structural Steelwork exposed to external atmosphere, aggressive environment, or embedded/bearing within external masonry, etc. to be hot dip galvanised.
 Structural Steelwork entirely within internal dry and non-aggressive environment is to be delivered to site primed and additional site coat of suitable and compatible zinc rich corrosion protective paint.
 1/2 hour fire protection to all Structural Steelwork using fireline board.
 - Structural Timberwork grade C24 and vac vac preservative treated, unless noted otherwise.

Rev	Date	
C	12/ 09/ 22	access to highway added
B	22/ 08/ 22	application site boundary altered
A	7/ 07/ 22	rear extension enlarged

RSCE Consulting Engineers
 Consulting Civil, Structural and Geotechnical Engineers

55 Garstang Road, Preston, Lancs. PR1 1LB
 tel. 01772 250163

Principal : R. Sparks B.Eng., M.Eng., C.Eng., MICE

Project	THORNLEY - KNOTT FARM, CHIPPING ROAD PR3 2TB		
Drawing Title	KNOTT FARM BARN PROPOSED CONVERSION TO SINGLE DWELLING SITE LOCATION AND BLOCK PLAN		
Scale	Date	Drawing No.	Rev.
As Shown	24/ 07/ 20	3526-005	B 22/ 08/ 22

© Crown copyright and database rights 2020 OS 100035409
 Reproduction in whole or in part is prohibited
 without the permission of Ordnance Survey.