

South Westerly Elevation - 1:100  
North Easterly Elevation - 1:100

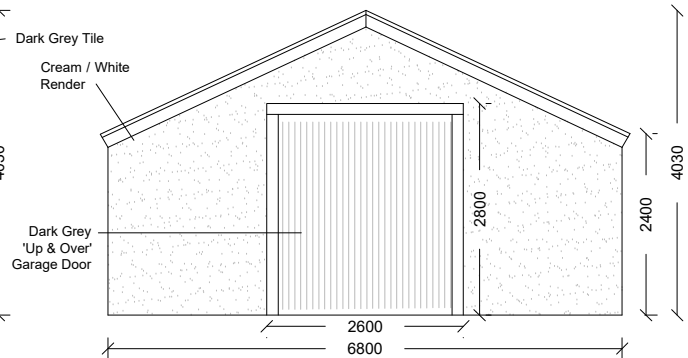

North Westerly Elevation - 1:100

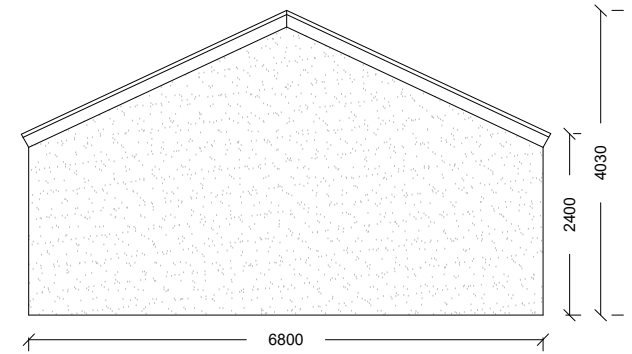

South Easterly Elevation - 1:100

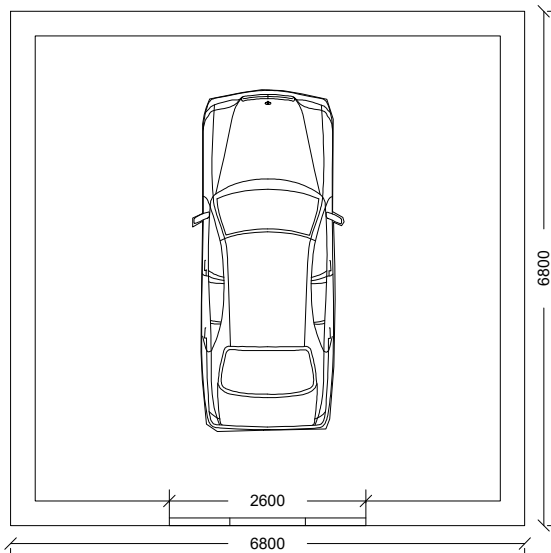

Floor Plan - 1:100

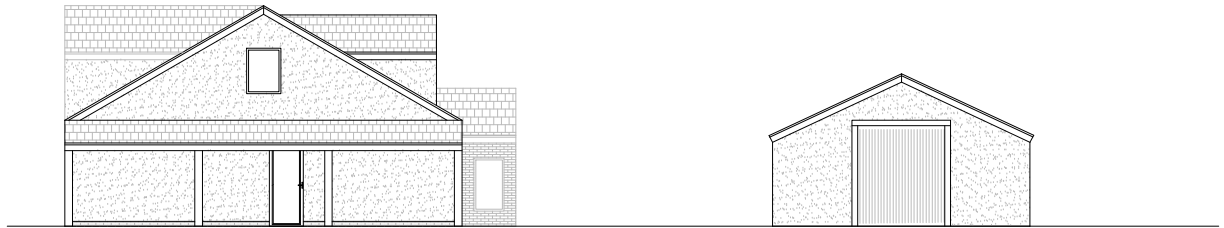

North Westerly Site Viewpoint - 1:200

**Amendment A - 05.01.2023:** Garage altered to reduce eaves & ridge height.

 <b>Gary Hoerty Associates</b> Gary Hoerty Associates Chartered Surveyors Suite 9 - Grindleton Business Centre The Spinney Grindleton Clitheroe Lancashire BB7 4DH T: 01200 449700 Email: info@ghaonline.co.uk	<b>Drawing No:</b> Hin.1068.3224.04A		<b>Notes:</b> All work is to be carried out to the latest current British standard Codes of Practice and recognised working practices. All work and materials should comply with Health and Safety legislation. All dimensions are in millimetres except where explicitly shown otherwise. The contractor should check and certify all dimensions as work proceeds and notify the architect of any discrepancies. Do not scale off the drawings, if in doubt ask.			
	<b>Project:</b> (No: Hin.1068.3224.GH )		Planning for New Bungalow at:  126 Ribchester Road Clayton le Dale BB1 9EE			
			<b>Client:</b> Mr. & Mrs. C. Hindle.		<b>Drawn:</b> KA	
		<b>Date:</b> 06.10.22		<b>Scale:</b> 1:100, 1:200 @ A4		
		<b>Amendments:</b>		A		