

SOUTH ELEVATION
Battery Pack Storage Shed

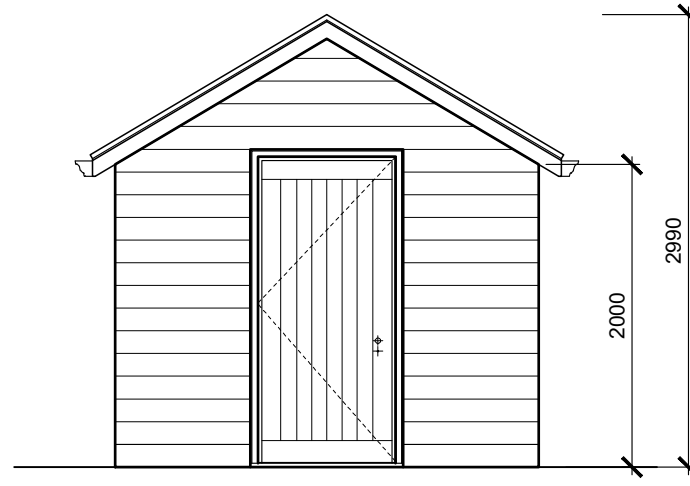

EAST ELEVATION
Battery Pack Storage Shed



NORTH ELEVATION
Battery Pack Storage Shed

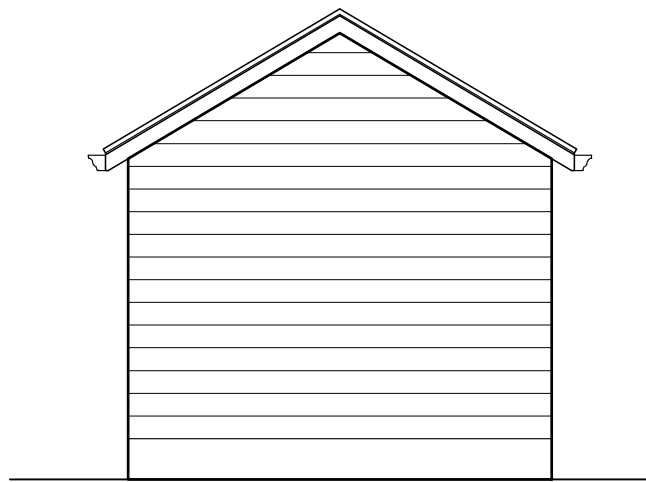

WEST ELEVATION
Battery Pack Storage Shed

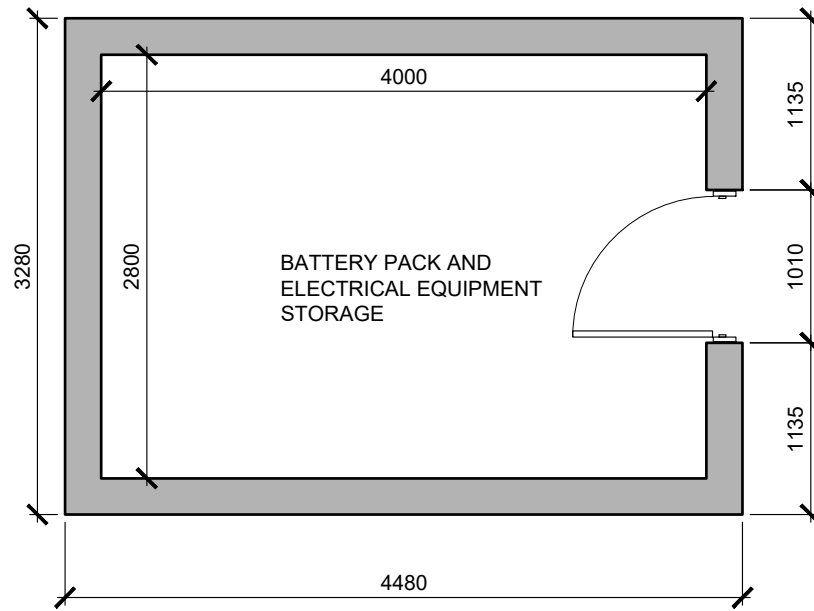

PLAN
Battery Pack Storage Shed

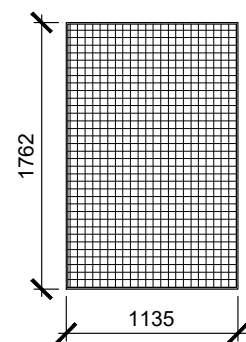

PLAN
Single solar panel (viewed flat)

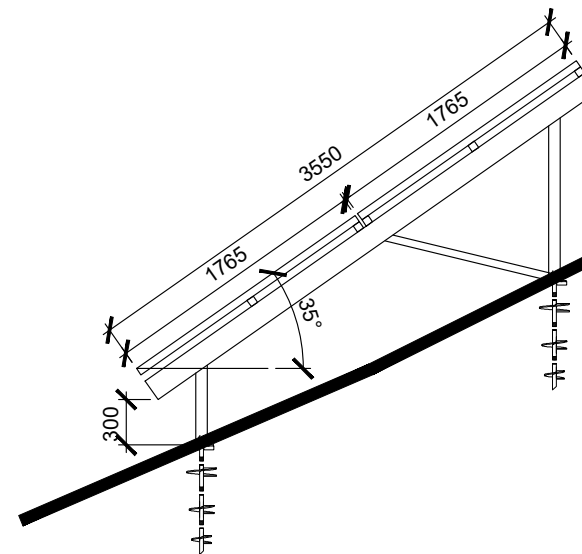

TYPICAL SECTION
Solar Panel and ground screw support system



- NOTES**
- All dimensions and levels are to be checked on site.
 - Any discrepancies are to be reported to the Shaw & Jagger Architects Ltd before any work commences.
 - This drawing shall not be scaled to ascertain any dimensions. Work to figured dimensions only.
 - This drawing shall not be reproduced without express written permission from Shaw & Jagger Architects Ltd.
 - Title overlay drawings and ownership boundaries are produced using all reasonable endeavors. Shaw & Jagger Architects Ltd cannot be responsible for the accuracy or scale discrepancy of base plans supplied to them.

drawing stage	PLANNING
drawing status	FOR APPROVAL

client
MR AND MRS B

project
PROPOSED SOLAR PANELS
WISWELL MANOR
PENDLETON ROAD, WISWELL

drawing title
PROPOSED PLANS AND ELEVATIONS

date	13/07/23	drawn	JR
scale	1:50@A3	checked	EJ



1 Cardale Park
Harrogate
North Yorkshire
HG3 1RY
Tel: 01423 532950
info@shawandjagger.com
www.shawandjagger.com

Job No 137/03 (02)004 # DWG No Rev