

Ribble Valley Borough Council
Planning Section
Council Offices
Church Walk
Clitheroe
BB7 2RA

Phone: 0300 123 6780
Email: developeras@lancashire.gov.uk
Your ref: 03.2023.652
Our ref: 03.2023.652
Date: 11.10.2023

For the attention of Emily Pickup

Planning Application No: 3/2023/0652

Proposal: Regularisation of installation of new wooden boundary fence to front garden.

Location: 5 Brookes Lane Whalley BB7 9RG

The submitted documents and plans have been reviewed and the following comments are made.

It is noted that this is a retrospective application with work completed on 10.3.23,

Brookes Lane (X7530) is a privately maintained cul-de-sac with low volumes of traffic and vehicles likely to be driving at less speed.

A scaled plan showing the driveway visibility splays is required for no. 3 and 5 Brookes Lane. See sketch below.

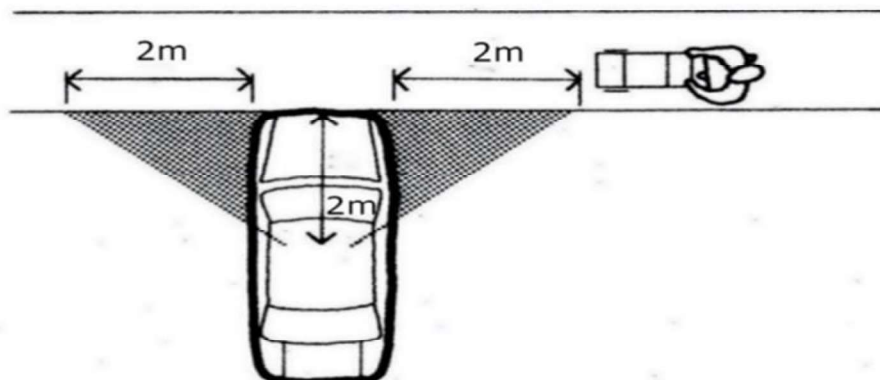

Kind regards

Lancashire County Council
PO Box 100, County Hall, Preston, PR1 0LD



Tahira

Tahira Akhtar BA (Hons)
Technician
Highways and Transport
Lancashire County Council

