



Proposals for Repair and Replacement Statement

Barn on Talbot Street,
Chipping,
Lancashire,
PR3 2QE



Contents

- 1.0 Introduction
- 2.0 Roofing and Truss Repairs
- 3.0 Replacement Doors and Windows
- 4.0 External Stonework
- 5.0 Bat Boxes
- 6.0 Electric Charging Points
- 7.0 Soil Pipe and Rainwater Goods

1.0 INTRODUCTION

This statement/document has been compiled to discharge the conditions for 'The Barn' on Talbot Street, Chipping, Lancs, PR32QE.

Following the granted planning permission for the above property there was a number of items which needs to be address prior to the start on site. This document will review and describe the proposed works to be undertaken at the barn and will be the base for the specifications which will be reviewed by Building Control.

2.0 ROOFING REPAIRS

The existing roof finish is to be removed to allow for new underlay to be installed. Existing Blue Slate to be reinstalled and any areas which need to be replaced will be done so with new blue slate. Care will be taken to find slates that will match the colour, finish and size.

Once new roof is on trusses to be left to dry for 7-14 days. Following this period trusses are to be inspected for water damage. An insect inspection is to follow with careful inspection with a torch and screw driver. Once the above is completed the following methondology is to be completed:

- brush the beam down with a fairly soft brush to remove any dust and loose dirt. Do not use a wire brush when cleaning up old beams. This will roughen the surface, damaging the appearance of the timber. This will also allow dirt to grip the surface more easily in the future, making the situation worse.
- Soda blasting or chemical free blasting to be used to remove smoke staining or blackening from moisture or fungi. Many cleaning chemicals will damage the wood, so should be avoided. Sand blasting is not recommended as again this will roughen the surface of the wood and damage the finish.
- Beams to be coated in beeswax polish – Linseed oil should be avoided as a finish.

3.0 REPLACMENT DOORS AND WINDOWS

The doors and windows are to be replaced with timber frames to achieve 1.41 and 1.7 W/m²K respectively. Please see the specification below for the doors – For continuity within the street scene both specifications are going to be the same as the Talbot Hotel:

Doors to be manufactured from high quality European Softwood from sustainable sources only. All timber to be knot free and preservative treated with an appropriate organic solvent and be Wood Protection Association (WPA) Commodity Specification C5 with a minimum service life of 30 years.

External frame moulding - ovolo profile moulding.

Proprietary threshold strip, weather seals and weather bar.

Glazing - 52mm deep x 22mm wide 'through' glazing bars (i.e., Individual window panes) - ovolo profile moulding internally.

Externally glazed and putty beaded.

Frame abutment to be externally sealed using burnt sand mastic of colour to match the proposed paint finish.

Glass units and whole product U-values: 16.4mm double glass unit (inside to outside), comprising 4mm Anti-sun green toughened / 6mm Argon gas filled cavity / Slim 6.4mm Softcoat Laminate. Whole window nom. U-value: 1.41 W/m²K.

Ironmongery: Fixed pin hinges, finish to client's specification.

Handles, locks, escutcheons, door knocker, to Client's choice of finish.

Multi-point locking to all doors.

Engineered clear grade knot free timber, all FSC certified.

Finish: Linseed paint of colour to client's specification.

Performance:

Air permeability: EN 1026:2000 - 600 pa.

Water tightness: EN 1027:2000 - 300 pa.

Wind resistance: EN 12211:2000 - 1200 pa

Windows to be manufactured from high quality European Softwood from sustainable sources only. All timber to be knot free and preservative treated with an appropriate organic solvent and be Wood Protection Association (WPA) Commodity Specification C5 with a minimum service life of 30 years.

Frame profile moulding - ovolo profile moulding internally.

Externally glazed and putty beaded.

Glass units and whole product U-values/ G-values.: 14.4mm double glass unit (inside to outside), comprising 4mm Anti-sun green toughened / 6mm Krypton filled cavity / 6.4mm laminate Planitherm 1.1 Low E. Whole window nom. U-value: 1.7 W/m²K / G-value: 0.52.

Friction hinges with traditional butt hinges optional.

Satin chrome (TBC), 3-point locking casement handles.

Fully weather-stripped for thermal and acoustic performance Frames to be finished using linseed paint to client's specification.

CE Marked EN 14351-1 + A1:2010

Security Tested PAS24:2016

Performance tested to BS6375 Parts 1,2 and 3



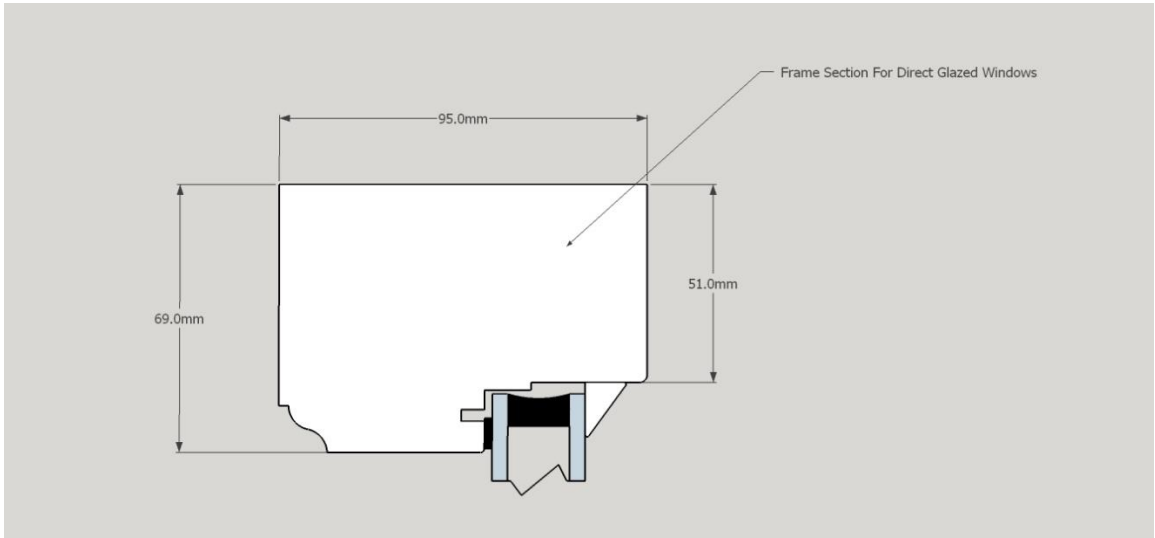

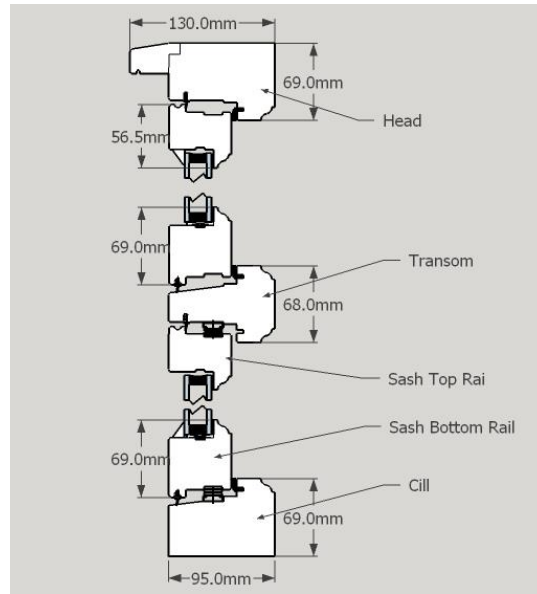
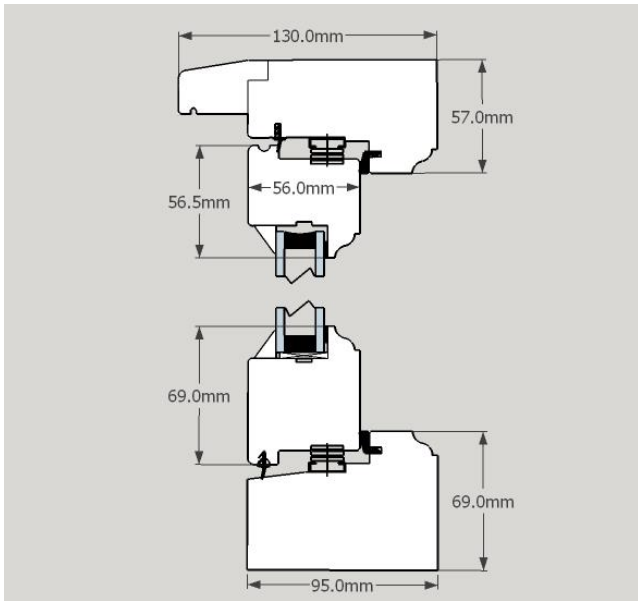
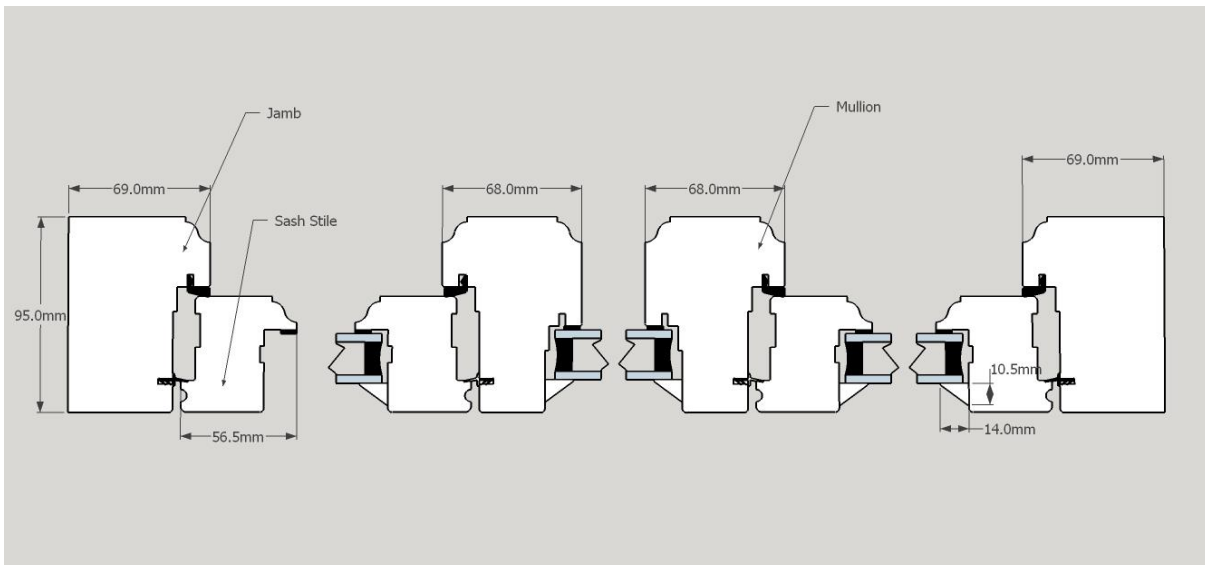

4.0 EXTERNAL STONEMWORK

The existing stonework is to be first brushed then washed. All dust/debris to be removed from walls prior to cleaning. The cleaning process should use a high temperature steam or air abrasion system in order to ensure the existing stone is not damaged.

Following this process the walls are to be repointed with Lime mortar. All works are to be undertaken in suitable weather conditions to ensure the mortar does not crack and dry correctly.

Preparation for repointing

- Work from bottom of the wall upwards.
- Remove loose or cracked mortar ONLY, carefully and without damaging adjacent masonry, arrises or widening joints. Form a neat recess of depth not less than 30mm or twice the thickness of the joint.
- When mortar beyond this depth is loose and friable and/or cavities are found seek instructions.
- Remove dust and loose debris and flush out with clean water.
- Dampen joints to control suction as necessary.

Re-pointing open-jointed masonry work

- Mortar: pre-bagged natural hydraulic lime (NHL 3.5) : sand, Mix: 1 : 2.5 - 3 (NHL : Sand) by volume.
- Sand source/type: good quality, well-graded washed, sharp coarse sand (particle size 3.35mm to 0.075mm).
- Joints: Finish mortar joints flush, approx. 1mm behind face of stonework.
- Other requirements: mortar to be carefully 'tamped' into the joint with a pointing iron and not trowelled which leaves the faces smeared. After initial setting and before fully dry, revisit area of pointing and carefully 'beat back' with a stiff bristle 'churn brush' until the mortar is recessed by approx. 1mm BEHIND FACE OF ADJACENT MASONRY. DO NOT SMEAR ADJACENT MASONRY.

Pointing with Tools/Irons

Press mortar well into joints using pointing tools/irons that fit into the joints, so they are fully filled. Ensure that no mortar encroaches/smears upon the face of the masonry. Use suitable temporary adhesive tape on each side of joints where necessary. Finish joints neatly as specified generally to full face of stonework.

After initial setting and before fully dry, revisit area of pointing and carefully 'beat back' with a stiff bristle 'churn brush' until the mortar is recessed by approx. 1mm behind face of adjacent stones.

Adverse weather & protection of mortars.

UNDER NO CIRCUMSTANCES re-point in natural hydraulic lime:sand mortars when the air temperature is at or below 5°C and falling or below 3°C and rising. Where it is anticipated that the temperature in the first few days might fall to 5°C, or lower, the structure should be protected with damp hessian to preserve the moisture and with sufficient cover, using bubble wrap or insulating material, to protect the structure itself and the mortar against frost. FROST RESISTANT ADDITIVES WILL NOT BE TOLERATED AS THEY CONTAIN SALTS WHICH WILL AFFECT THE MORTAR.

- Maintain temperature of the work above freezing until mortar has fully set.
- Protect re-pointed walls against rain and snow by covering when precipitation occurs and at all times when work is not proceeding.
- Prevent re-pointed walls from drying out too rapidly in both hot conditions and from the effects of the wind by covering with damp hessian as soon as possible to maintain moisture and then with additional cover to prevent the hessian drying out. For best results the moist conditions should be maintained, whilst allowing air movement over the mortar, for as long as is practicable.
- Rake out and replace mortar damaged by frost and where instructed, redo the repair

5.0 BAT BOXES

Conservation Bat Box

This Conservation Bat Box is designed for multi species of bat occupancy, it has an angled cut-away front with ladder style grooves and two vertical chambers for the bats to choose from. The bat chambers can be accessed for inspection by licensed bat handlers via the hinged roof which is secured by a removable screw (see images). The open design of this bat box reduces the need to clean, the rear panel has a recycled plastic hanger and a pre-drilled hole at the base of the bat box ladder for ease of installation.

Bat Box siting

Site 2.5 - 5m high on a building, mature trees or vegetation line (trees/tall hedge), or feeding/flight route in partial daytime sun. Face box preferably to get partial warmth from the sun South to SE, or N (cool). Ideally fit multiple boxes at a time for best results

Conservation Bat Box dimensions:

H450 x W330 x L140mm

Weight: 2.40kg

It is illegal to disturb any bat when it is roosting, or to handle a bat without a licence. However, you can monitor your bat box by looking for mouse-sized droppings beneath the bat box as a clue to occupation or observe from a distance at dusk to see if bats are exiting the box to hunt.



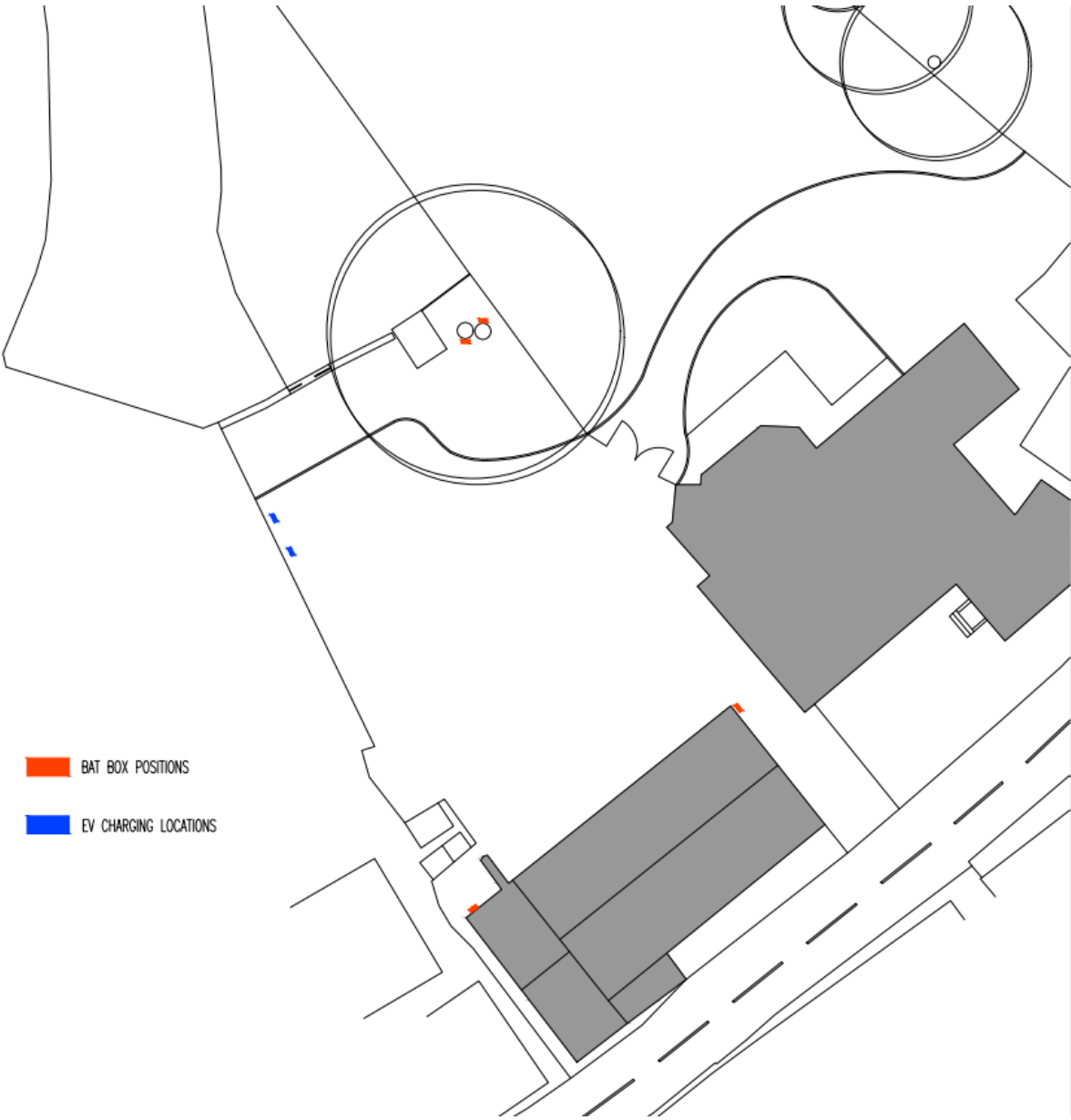

6.0 ELECTRIC VEHICLE CHARGING POINTS

Electric vehicle charging points will be installed to the manufacture's specifications and fitting instructions.

See above plan to show the locations for the 2 chargers.



7.0 SOILPIPE AND RAINWATER GOODS

Heritage aluminium 110mm soil pipes to be painted black. Pipes to be screwed back to stone face using noncorrosive screws and brackets.

New downpipes to be 68mm round aluminium painted black. Pipes to be screwed back to stone face using noncorrosive screws and brackets.

New guttering to be moulded aluminium painted black. Guttering to be mounted on raise and fall brackets to ensure adequate falls over the length of each property. Guttering to be supplied and fitted with stop ends, brackets, corner sections and outlets.

