



Drainage Strategy Report

Alston Dairy
Alston Lane
Preston
PR3 3BN

PN0259-PEL-DS-01

04.07.25

This document prepared by Pluviam Environmental Limited (PEL), its contents and any supporting information relating to this document should not be used for any purpose other than that for which it was prepared and provided. Should the document be forwarded to other parties for information, the whole of the report and any supporting information should be so copied, but no professional liability or warranty shall be extended to other parties by PEL in this connection without the explicit written agreement thereto by PEL.

Project No: PN0259

Date: July 2025

Revision	Purpose	Date
1.0	First Issue.	04.07.25

Produced By:



John Roberts CSSW
Director

Checked By:

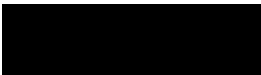

Rod Green MSc, BSc(Hons), IENG, FCIPHE, MSOPHE
Director

CONTENTS

1. Introduction	2
2. Drainage Design Proposals	3
Ground Conditions	3
Drainage Strategy Design Parameters	4
Discharge Review	5
Engineering Challenges	6
Stormwater Calculation Inputs	6
Contributing Areas	7
Attenuation	9
Pollution Removal	9
High Flow and Exceedance Events	10
Integration with the landscape	10
3. Overview of Drainage Proposals	11
Outline Design	11
4. Maintenance	13
Management Responsibilities	13
Managing SuDS	13
Routine maintenance	13
5. Conclusion	17

Appendices

Appendix A – Site Investigation – Borehole Extracts

Appendix B – Existing Drainage Investigation

Appendix C – United Utilities Sewer Record Map

Appendix D – GFFR Calculation

Appendix E – CIRIA SIA Tool - Pollution

Appendix F – InfoDrainage Model Results

Appendix G – Proposed Outline Drainage Layout and Details

1. INTRODUCTION

The following proposal outlines the foul and storm water drainage management system proposed for the Alston Dairy development. The site is located at National Grid Reference (NGR) 360190, 435510 and postcode PR3 3BN.

The site is situated approximately 1.7km south of Longridge and 8.5km northeast of Preston. The site is bound by Pinfold Lane to the north, Preston Rd (B6243) to the west, residential houses and Bolton Fold Farm to the south and a residential house and farmland to the east.

This planning application seeks planning permission for the construction of a dairy extension with an associated car park and delivery area.

Staff parking is to be extended with a dedicated staff car park and the internal driveway from Preston Road is to be widened.

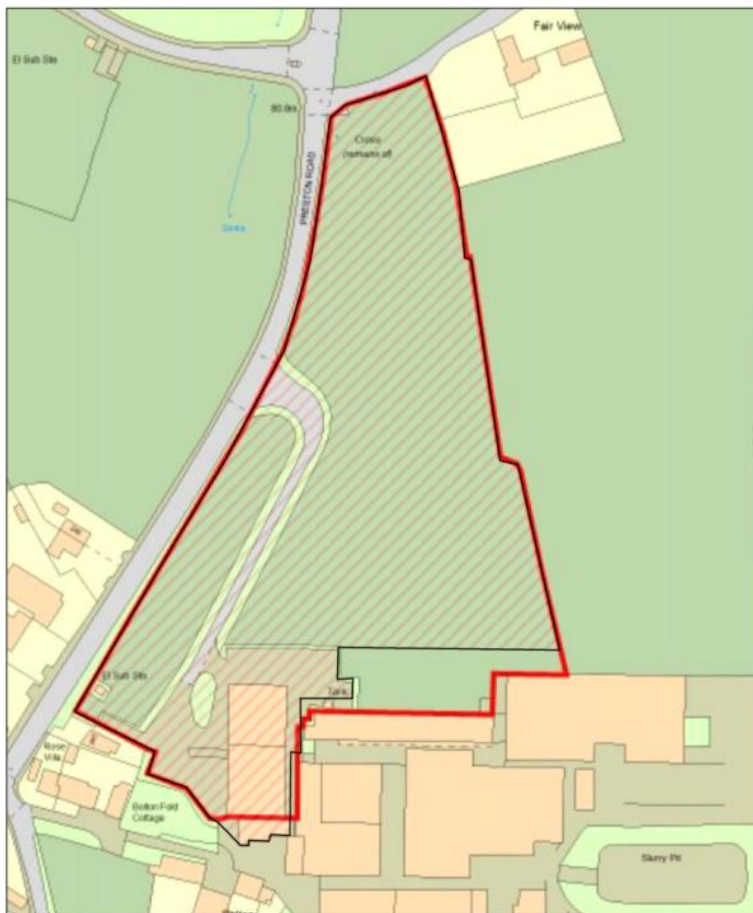

Figure 1.1. Site Location and Planning Boundary

2. DRAINAGE DESIGN PROPOSALS

Ground Conditions

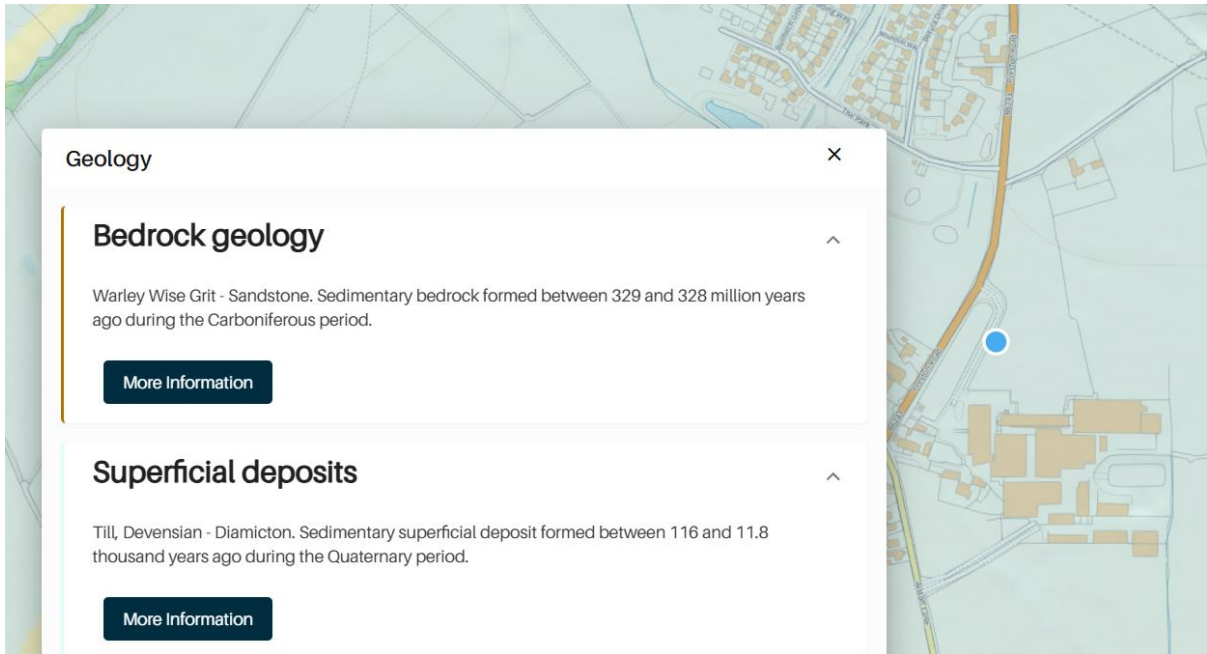

Figure 2.1 bedrock map (left) and superficial deposits map (right) with the location of the site outlined in blue.

The British Geological Society GeoIndex indicates that the site bedrock is Warley Wise Grit- Sandstone Formation. The superficial deposits are Till, Devensian Deposits – clay, and silt.

According to the classifications determined by the National Soil Resources Institute (Figure 2.2), the primary soil type on the site is ‘loamy and clayey soils with naturally impeded drainage’.

Borehole results can be found in Appendix A, which agree with the NSRI description and characteristics.

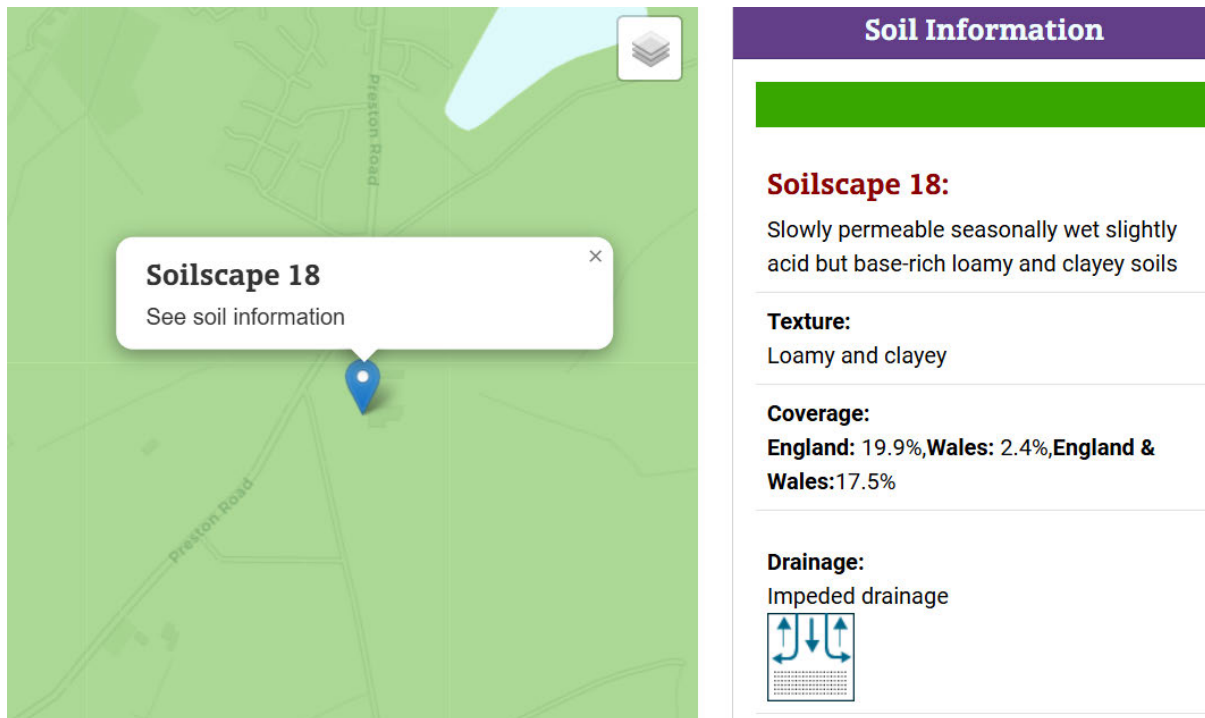

Figure 2.2 LandIS Soilscales map

Drainage Strategy Design Parameters

The drainage strategy is developed in line with the following documents:

National Planning Policy Framework (NPPF) requires that new developments should not increase flood risk both on the Site and in the area surrounding it. Therefore, surface water runoff should not exceed the peak volumes already generated on the Site and betterment should be provided where possible.

Environment Agency Climate Change Guidance provides peak rainfall intensity allowances to be applied during drainage design for each Management Catchment, using the upper end 2070s epoch allowances for surface water in developments with lifetimes beyond 2100. Refer to section **Error!**

Reference source not found..

DEFRA National Standards for Sustainable Drainage Systems provide statutory guidance on the peak flow and volume from a development as well as managing flood risk within the development. Notably relevant standards include:

1. Runoff destinations – Discharge must follow a clearly defined hierarchy, with evidence needed to justify use of lower priority routes. Rainwater reuse and infiltration are prioritised.
2. Interception of everyday rainfall – Requires that the first 5mm of most rainfall events (80% in summer, 50% in winter) is retained on site through source control measures.

3. Extreme rainfall and flood risk – Addresses 1:1 and 1:100 AEP events, urban creep, exceedance routes, and climate change allowances.
4. Water quality protection – Requires robust risk assessment and SuDS trains tailored to land use pollution risks.
5. Amenity benefits – SuDS should be multifunctional and enhance landscape character, health, education, and placemaking.
6. Biodiversity enhancement – Drainage systems must contribute to habitat creation, BNG, and LNRS goals.
7. Design for construction, operation and maintenance – Emphasises whole-life design, access, inspection, and resilience.

The updated discharge hierarchy notes the priority routes:

1. Collected for non-potable use;
2. Into the ground (infiltration);
3. To a surface water body;
4. To a surface water sewer, highway drain, or another drainage system; and
5. To a combined sewer.

Additionally, Pluviam Environmental Ltd has reviewed the information provided and considered an approach based on previous experience of similar sites and current SuDS guidance provided in:

- Sustainable Design and Construction - Supplementary Planning Guidance, April 2014.
- CIRIA report C753 (2016); The SUDS manual
- CIRIA Report C724 (2013) Creating water sensitive places-scoping the potential for water sensitive urban design in the UK.
- BS 8582:2013, Code of practice for surface water management for development sites

Discharge Review

Water Reuse – non-potable

Passive irrigation shall be used to utilise the incoming water to irrigate the raingardens. A rainfall depth far above the first 5mm will be captured within the 4 no. raingardens and vegetated swale sides. This will be utilised for irrigation of the planting and lost via evapotranspiration or captured within the void and held in surface tension.

Discharge via infiltration

Where possible, infiltration should be incorporated into the final design of the drainage. Infiltration should be the second consideration for drainage outfall.

However, boreholes adjacent to site show clay from surface level down to at least 5m below ground level. Therefore, it is unlikely that infiltration will be feasible. Soilscales notes impeded drainage and poor infiltration.

See Appendix A for borehole logs.

Discharge via a watercourse

Discharge shall be to the surface water culvert via an existing private connection. Investigation (dye testing) by Sleater Watson has shown that the culvert connects to the River Ribble via the Tun Brook. A private manhole and connection exists on site. The culvert is wholly within the client's (site owner) land and connection will be made on the clients site.

See existing drainage investigations in Appendix B.

Surface water and combined sewers

The United Utilities sewer record is available in Appendix C. There are no public sewers close to site which do not involve crossing third party land for connection. Therefore, no drainage will go to the public assets.

Engineering Challenges

The key engineering challenges for this site from a drainage design perspective are:

- Managing the 100 year storm event with 50% added to peak flows for climate change;
- Treatment of surface water runoff;
- Attenuation and discharge into the local combined sewer at 6.9 l/s, greenfield runoff rate.

Stormwater Calculation Inputs

The SuDS system is designed to store and attenuate below ground a 100yr return period storm event plus an additional 50% for climate change (see Figure 2.3 below).

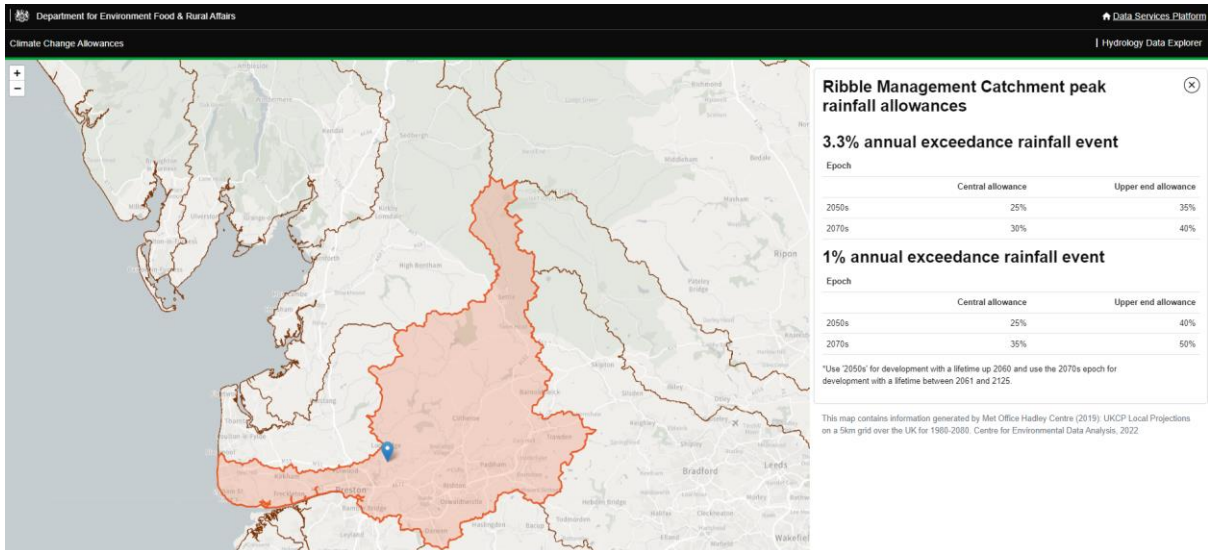

Figure 2.3 DEFRA climate change allowances for rainfall

Location:	Alston, Preston
FEH Data 2022	
Existing impermeable catchment area:	0.1 ha (existing road)
Proposed impermeable Catchment area:	0.565 ha
Storm Event:	100 years
Climate Change Factor:	50% Upper End
Greenfield Flow Rate QBar:	6.9 l/s (Appendix D)
Proposed design 1in100 + 50% storm event flow rate:	6.6 l/s
Urban creep is set at 0% as the whole of the development is agricultural in nature.	

Contributing Areas

The site has been divided into 16 drainage areas, as shown in Figure .4 **Error! Reference source not found.** lists the area in m² and outgoing connections for each drainage area. All contributing areas have a PIMP of 0.90 with 1 set for both summer and winter (Cv).

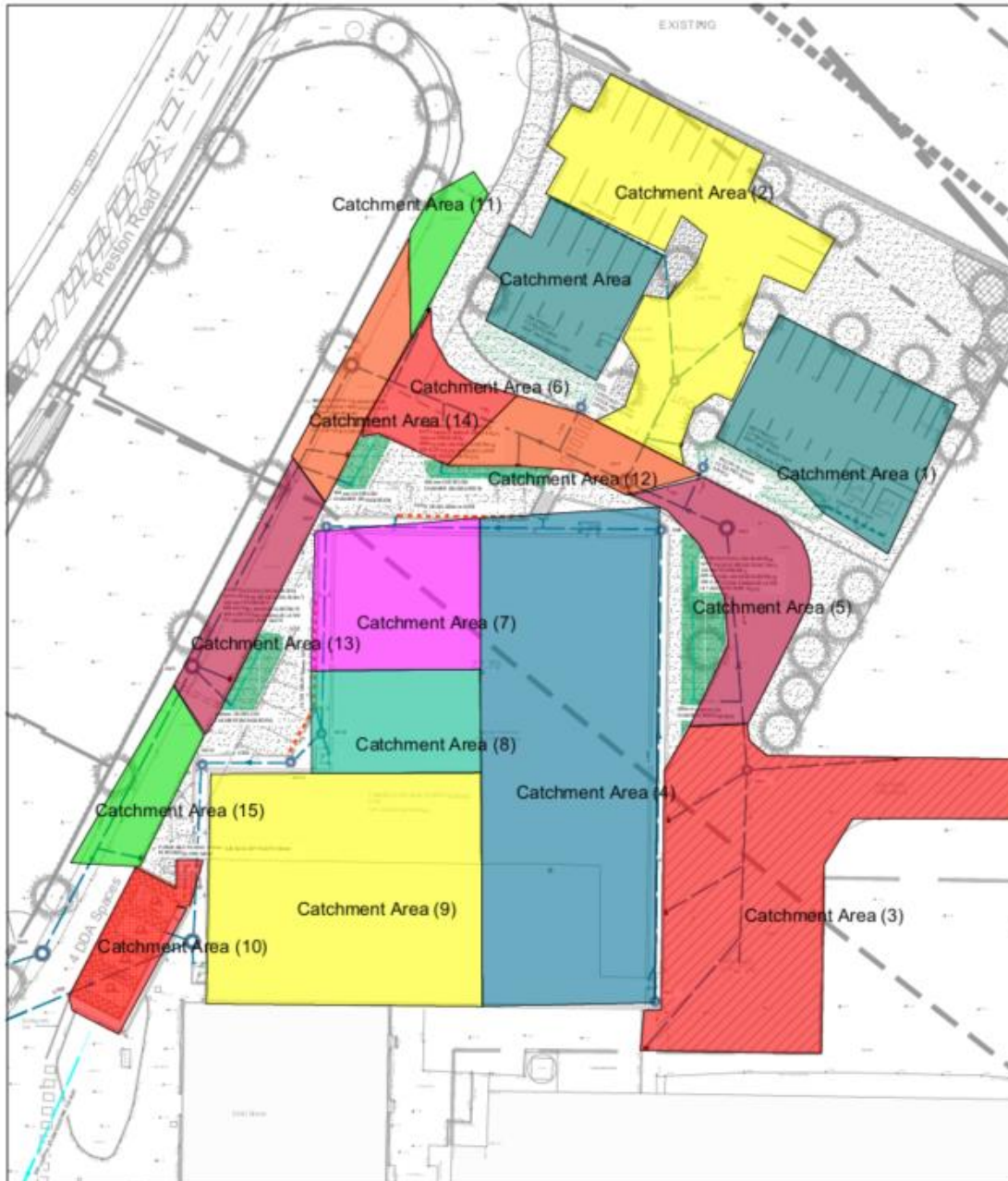

Figure 2.4 Contributing drainage areas

Table 2.1 (below) Contributing drainage areas

Name	Outgoing Item	Area
Catchment Area	Dry Swale 1	0.025
Catchment Area (1)	Dry Swale 2	0.04
Catchment Area (2)	SW3	0.063
Catchment Area (3)	SW1	0.084
Catchment Area (4)	SW8	0.103
Catchment Area (5)	Bioretention 1	0.026
Catchment Area (6)	SW4	0.014
Catchment Area (7)	SW9	0.027
Catchment Area (8)	SW10	0.02
Catchment Area (9)	SW13	0.082

Catchment Area (10)	Porous Paving	0.014
Catchment Area (11)	SW4	0.008
Catchment Area (12)	Bioretention 2	0.015
Catchment Area (13)	Bioretention 4	0.017
Catchment Area (14)	Bioretention 3	0.014
Catchment Area (15)	SW6	0.013
Total		0.565

The total impermeable (and actively drained) area on the site is 5,640 m².

Attenuation

To prevent flooding on the site in a 1 % AEP + 50 % climate change storm, the storage areas need the following capacity:

Table 2.2 Attenuation volumes

Name / location	Required volume (m³)	Indicative dimensions and porosity
Tank (cellular)	333	20.5m x 10m 1.6m deep (97% void)
Dry Swale 1	7.5	46 sq.m and 400mm deep with 100% void
Dry Swale 2	5.6	46 sq.m and 400mm deep with 100% void
Permeable Paving	6.7	300 mm deep, 30% void 4/20 stone
Bioretention 1 (Raingarden) with passive irrigation	11.1	150mm freeboard (100% void), 600mm substrate (25% void) and 200mm 4/20 stone (30% void)
Bioretention 2 (Raingarden) with passive irrigation	5.2	150mm freeboard (100% void), 600mm substrate (25% void) and 200mm 4/20 stone (30% void)
Bioretention 3 (Raingarden) with passive irrigation	4.5	150mm freeboard (100% void), 600mm substrate (25% void) and 200mm 4/20 stone (30% void)
Bioretention 4 (Raingarden) with passive irrigation	6.2	150mm freeboard (100% void), 600mm substrate (25% void) and 200mm 4/20 stone (30% void)

Pollution Removal

As per the CIRIA Simple Index approach, a delivery yard/car park is medium risk and needs mitigation indices that meet 0.8, 0.6 and 0.9 for total suspended solids (TSS), metals and

hydrocarbons respectively. This is met with a Bypass separator (SuDS also included but not considered in calculation). The calculations are shown in Appendix E using the CIRIA SIA tool.

High Flow and Exceedance Events

As per non-statutory technical standard S8, flooding is permitted on site in events exceeding 3.3 % AEP + climate change, so long as it does not flood buildings or critical infrastructure in a 1 % AEP + climate change event. For events in excess of 1 % AEP + climate change, S9 states that flows should be managed in exceedance routes that minimise the risks to people and property.

The InfoDrainage modelling presented in **Error! Reference source not found.** predicts that in the 1 % AEP + 50 % storm event, 0 m³ of flooding would occur.

Flooding beyond the extreme design storm event would follow the following pathway:

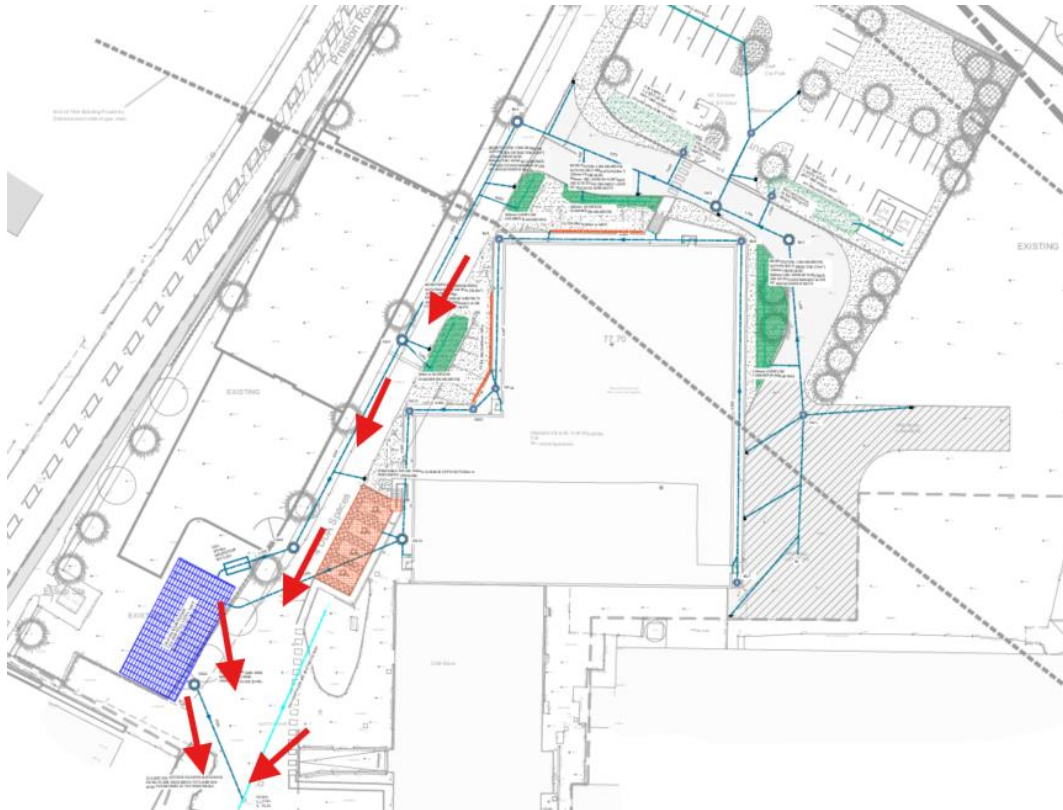

Figure 2.5 Exceedance routing

Integration with the landscape

Naturally planted swales and native species raingardens have been suggested by Pluviam Environmental to provide, biodiversity, amenity and treatment of any runoff passing through the devices.

3. OVERVIEW OF DRAINAGE PROPOSALS

Outline Design

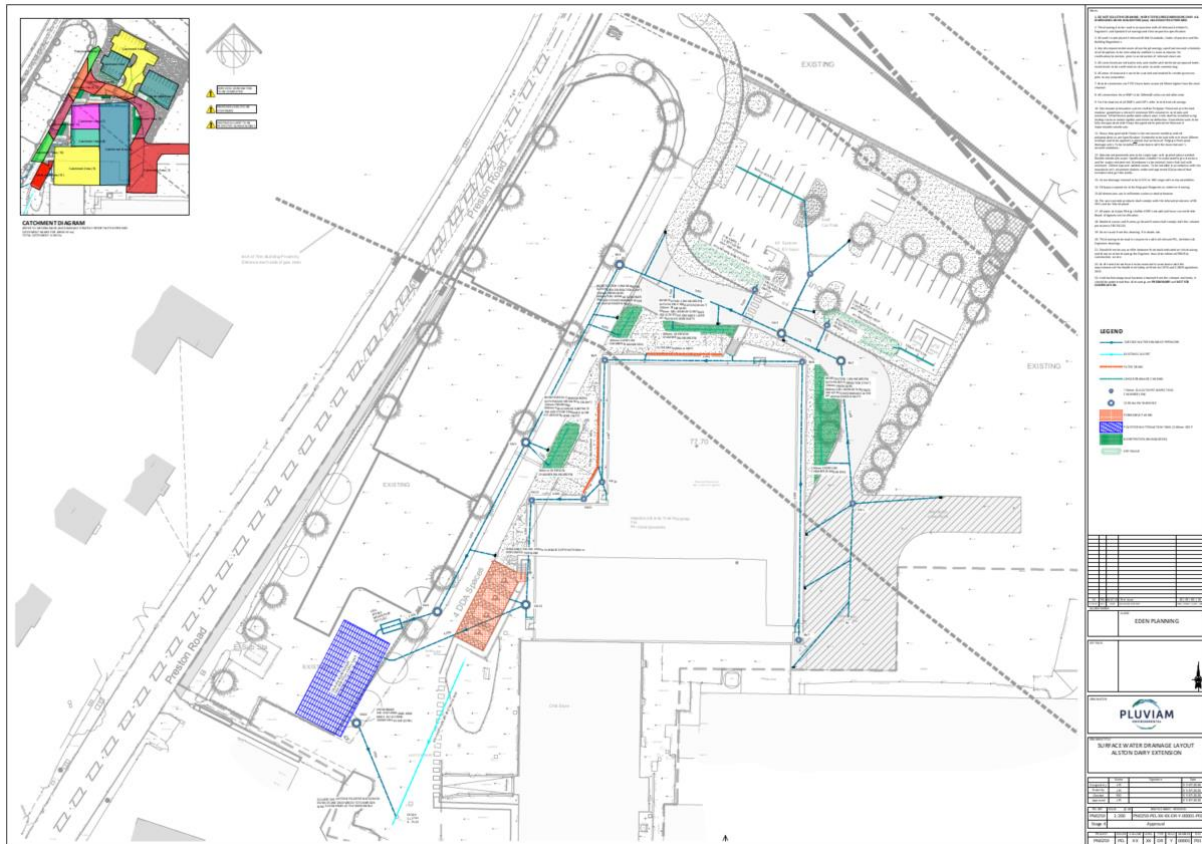

Figure 3.1 Outline drainage design and details (available full size in Appendix G)

The drainage design is based on achieving source control and treatment of the run-off from the proposed development.

The proposed drainage shall discharge to the existing onsite private connection to the culverted watercourse.

The hardstanding areas shall be collected primarily within raingardens and swales and supplemented with conventional gullies and channels where required. The hardstanding areas will pass through bypass separators for treatment prior to discharging into a geocellular attenuation tank. A small area adjacent to the proposed extension providing disabled spaces shall be collected within permeable paving (which will also provide treatment).

The building roofs shall discharge to respective network geocellular attenuation tanks via silt trap manholes.

The geocellular attenuation tank and Hydrobrake device are provided to limit the flows to Greenfield runoff rate. The Greenfield runoff rate 6.9 l/s. However, 6.6 l/s will be utilised as the design flow rate

during the 1in100+50% climate change storm event. The outline surface water calculations completed in InfoDrainage can be found in Appendix F.

Please refer to: PEL outline layout drawing PN0259-PEL-XX-XX-DR-Y-0001, Appendix G, for the proposed surface water drainage layout and PN0259-PEL-XX-XX-DR-Y-0002 for the proposed details.

4. MAINTENANCE

Management Responsibilities

The management, operation and maintenance of the soft SuDS features will be undertaken by Alston Dairy. The dairy operation has a robust maintenance regime currently in place. However, specific tasks based on the proposed design are note below. This document will be provided to the diary at handover.

Managing SuDS

The SuDS has been designed for easy maintenance and comprises:

- Regular care – litter collection, manage vegetation growth and checking inlets where water enters the raingardens/tree pits. Inspection after major storm events for signs of blockage and debris.
- Occasional tasks – checking the inlets, catchpits and pipework and removing any silt/debris that builds up in the SuDS feature.
- Remedial Work – repairing damage where necessary, manage vegetation growth all in accordance with the current CIRIA SUDS Manual.

Routine maintenance

The following routine maintenance procedures are recommended:

- Remove silt/debris from back inlet gullies and yard gullies as required.
- Remove silt/debris from inspection chambers as required.
- Remove silt/debris from linear drainage channels as required.
- Remove siltation from attenuation tank via low flow high volume pressure jetting.
- Records of inspections and maintenance undertaken should be kept by the client.

Management of maintenance to be undertaken by Alston Dairy.

Separators should follow the maintenance and management plan specified by the supplier. They are specialist units which require the manufacturers guidance to be adhered to.

Maintenance activities comprise:

General Requirements
<ul style="list-style-type: none"> • Regular maintenance • Occasional tasks • Remedial work
<p>General Litter - collect all litter or other debris and remove it from site at each visit. Landscaping and mowing.</p>

- Avoid use of weed-killers and pesticides to prevent chemical pollution
- Avoid de-icing agents wherever possible
- Protect all below ground drainage through careful selection and placement of hard and soft landscaping.

Specific Maintenance

Raingardens and Swales	
Regular maintenance	Frequency
Inspect and identify any areas that are not operating correctly. If required take remedial action.	Monthly for three months then annually
Remove debris from the catchment surface (where it may cause risks to performance)	Monthly
Remove sediment from pre-treatment inlet structures and inspection chambers.	Annually or as necessary
Maintain vegetation and prune any dead vegetation. Remove invasive plants and weeds regularly.	Annually or as necessary
Occasional maintenance	Frequency
Check topsoil levels are 20mm above edges of chambers to avoid mower damage.	As necessary or every three months
Remedial work	Frequency
Repair physical damage if necessary.	As required

Geocellular Tank	
Regular maintenance	Frequency
Inspect and identify any areas that are not operating correctly. If required take remedial action.	Monthly for 3 mths then annually
Remove debris from the catchment surface (where it may cause risks to performance)	Monthly
	Annually or as required

Remove sediment from pre-treatment inlet structures and inspection chambers. Maintain vegetation (grass, hedges and trees) to designed limits within the vicinity of below ground drainage pipes and tanks to avoid damage to system. Remove nuisance plants.	Monthly or as required
Remedial work	Frequency
Repair physical damage if necessary	As required
Monitoring	Frequency
Inspect all inlets, outlets and vents to ensure that they are in good condition and operating as designed Survey inside of tank and pipe runs for sediment build up and remove if necessary	Annually Every 5 years or as require

Chambers and Channels	
Regular maintenance	Frequency
Inlet Structures Inspect rainwater down pipes, channel drains, silt traps, inspection chambers and road gullies, removing obstructions and silt as necessary. Check there is no physical damage Strim vegetation 1m min surround to structures and keep area free from silt and debris	Monthly Monthly
Inspection Chambers and below ground control chambers Remove cover and inspect, ensuring that the water is flowing freely and that the exit route for water is unobstructed. Remove debris and silt.	Annually

Undertake inspection after leaf fall in autumn	
Occasional maintenance	Frequency
Check topsoil levels are 20mm above edges of chambers to avoid mower damage	As necessary
Remedial work	Frequency
Repair physical damage if necessary	As required

Waste Management

- **Litter** shall be disposed of offsite at an appropriate recycling facility.
- **Grass cuttings** shall be composted.
- **Sediment** arising from clearing silt traps, pipes, inspection chambers shall be disposed of according to EA guidance.

Any variance to the above shall follow the guidance of the CIRIA SuDS manual.

Spillage – Emergency Action

Spillages of oil or other COSHH substances should be removed where possible using soak mats as recommended by the Environment Agency.

In the event of a serious spillage, either by volume or of unknown or toxic compounds, then isolate the spillage with soil, turf or fabric and block outlet pipes from chamber(s) downstream of the spillage with a bung(s). (A bung for blocking pipes may be made by wrapping soil or turf in a plastic sheet or closely woven fabric).

Contact The Environment Agency immediately.

5. CONCLUSION

The proposed SuDS design meets the requirements of the CIRIA SuDS Manual C753.

The system is designed to collect, treat, and attenuate the rainwater runoff from the new impermeable areas and discharge into the existing surface water culvert.

The proposed surface water drainage system combines existing conventional drainage principles and products along with source control techniques and components.

Appendix A

Site Investigation – Borehole Extracts



LEONARD FAIRCLOUGH, LIMITED

SITE INVESTIGATION DIVISION

Chapel Street, Adlington, Lancashire PR7 4JP

Telephone: ADLINGTON 264 & 471 Telex: 67510

B.H. No. ~~22/10~~ No. 74/105

Location HOGHTON TO WHITTINGHAM PIPELINE

Client PRESTON AND DISTRICT WATER SUPPLY UNIT Scale 1:50

BOREHOLE LOG SHEET

SD 53 NE 19

[5934 3518]

Date 5-5-75

Rig 150mm PERCUSSION

Description	O.S.D.	Legend	Depth	Thickness	Sample	S.P.T. "N" Value	Water Levels
TOPSOIL			0.00	0.15			
Brown and Grey Sandy CLAY			0.15	1.05			
Firm to Stiff Brown Gravelly CLAY			1.20		○ 1.00		BOREHOLE DRY
					○ 2.00		
				3.80	○ 3.00		
					○ 4.00		
				5.00	○ 5.00		
							BOREHOLE COMPLETED

Undisturbed Sample

Disturbed Sample

Water Sample

Standard Penetration Test

510*

Appendix B

Existing Drainage Investigation

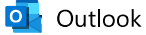

RE: Alston Dairy

From [Redacted]
Date [Redacted]
To [Redacted]

Hi Nicole,

The survey was carried out, due to the very dry weather the dye took a very long time to move downstream but we found the dye in Tun Brook which discharges into the River Ribble.

Regards

Michael Billington

For and on behalf of



Telephone: [Redacted]
Address: 26 West Cliff, Preston, Lancashire, PR1 8HU.
Website: www.sleaterwatson.co.uk

Follow us on LinkedIn



The information contained within this email and any attachments are intended solely for the use of the individual or organisation to whom it is addressed. It may contain privileged or confidential information and should under no circumstances be copied to a third party. If you are not the intended recipient, please notify the sender and remove it completely from your system. All emails and attachments are virus checked, however, Sleater & Watson LLP accepts no responsibility for loss or damage resulting from their use, including that from computer viruses.

Sleater & Watson LLP - Registered in England & Wales, Registered Number: OC311390, Registered Office: Chandler House, 7 Ferry Road Office Park, Riversway, Preston, PR2 2YH.

From [Redacted]
Sent [Redacted]
To: [Redacted]
Subject: RE: Alston Dairy

Good morning,

@Michael Billington did the survey happen as planned?

Kind regards

Nicole Roe
Director

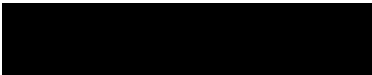

E: nicole@edenplanning.co.uk
1 Market Street . Altrincham . WA14 1QE
edenplanning.co.uk

E D E N

View our work: [Track Record](#)

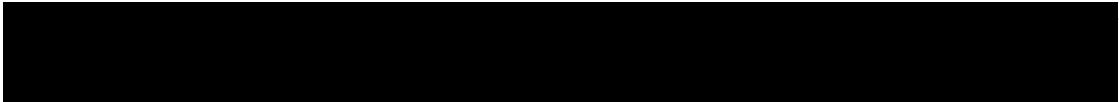

Subject: RE: Alston Dairy [Filed 16 May 2025 10:43]

Thank you for letting us know. @'John Roberts' how long do you envisage needing after this?

Appendix C

United Utilities Sewer Record Map

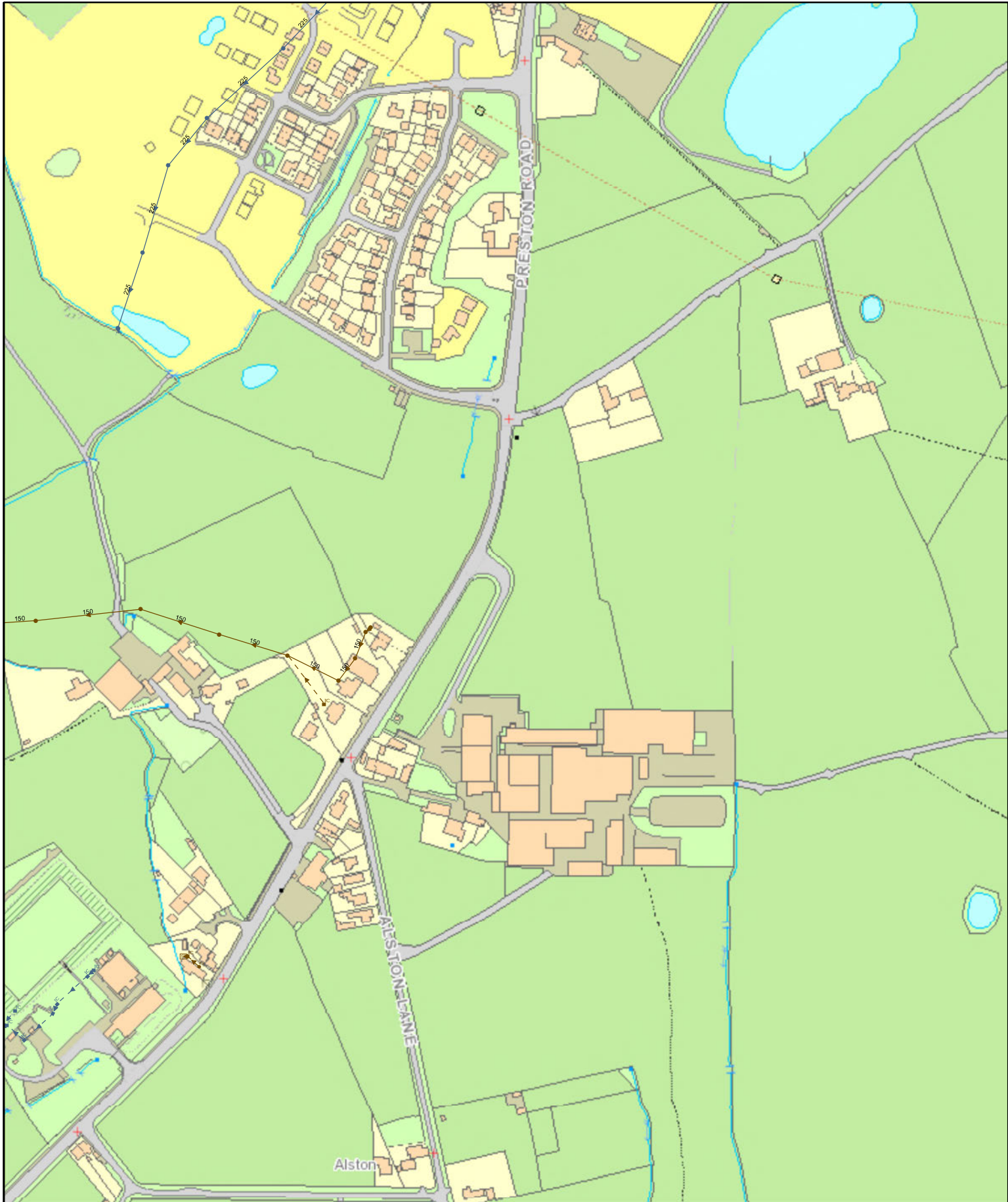

Date: 25/03/2022

Extract from Map of Public Sewers

Printed By:

Property Search and surrounding area Pinfold Lane & Preston Road Longridge Pl



The position of underground apparatus shown on this plan is approximate only and is given in accordance with the best information currently available. The actual positions may be different from those shown on the plan and private pipes, sewers or drains may not be recorded. United Utilities Water PLC will not accept any liability for any damage caused by the actual positions being different from those shown.

© United Utilities Water PLC 2017. The plan is based upon the Ordnance Survey Map with the sanction of the Controller of H.M. Stationery Office, Crown copyright 100022432 and United Utilities Water PLC copyrights are reserved. Unauthorised reproduction will infringe these copyrights.

Appendix D

GFFR Calculation

This is an estimation of the greenfield runoff rates that are used to meet normal best practice criteria in line with Environment Agency guidance “Rainfall runoff management for developments”, SC030219 (2013), the SuDS Manual C753 (CIRIA, 2015) and the non-statutory standards for SuDS (Defra, 2015). This information on greenfield runoff rates may be the basis for setting consents for the drainage of surface water runoff from sites.

Project details

Date	<input type="text" value="02/07/2025"/>
Calculated by	<input type="text" value="John Roberts"/>
Reference	<input type="text" value="AlstonD"/>
Model version	<input type="text" value="2.0.1"/>

Location

Site name	<input type="text" value="Alston"/>
Site location	<input type="text" value="Alston"/>

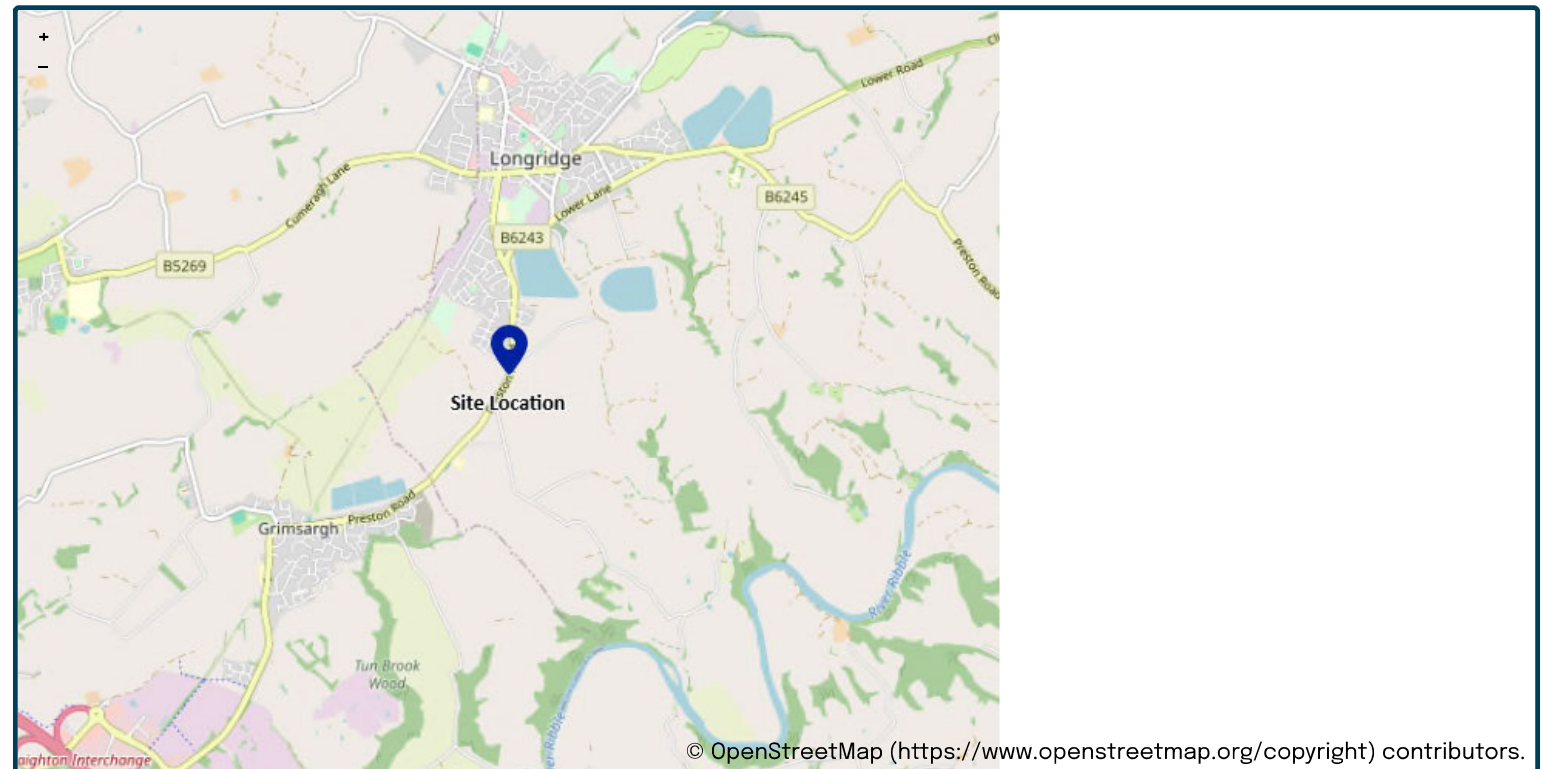

Site easting	<input type="text" value="360158"/>
Site northing	<input type="text" value="435418"/>

Site details

Total site area (ha)	<input type="text" value=".564"/>	ha
----------------------	-----------------------------------	----

Greenfield runoff

Method

Method

FEH statistical

	<u>My value</u>		<u>Map value</u>
SAAR (mm)	<input type="text" value="1094"/>	mm	<input type="text" value="1094"/>
BFIHOST	<input type="text" value=".351"/>		
QMed-QBar conversion	<input type="text" value="1.075"/>		<input type="text" value="1.075"/>
QMed (l/s)	<input type="text" value="6.41"/>	l/s	
QBar (FEH statistical) (l/s)	<input type="text" value="6.9"/>	l/s	

Growth curve factors

	<u>My value</u>		<u>Map value</u>
Hydrological region	<input type="text" value="10"/>		<input type="text" value="10"/>
1 year growth factor	<input type="text" value="0.87"/>		
2 year growth factor	<input type="text" value="0.93"/>		
10 year growth factor	<input type="text" value="1.38"/>		
30 year growth factor	<input type="text" value="1.7"/>		
100 year growth factor	<input type="text" value="2.08"/>		
200 year growth factor	<input type="text" value="2.37"/>		

Results

Method	<input type="text" value="FEH statistical"/>	
Flow rate 1 year (l/s)	<input type="text" value="6"/>	l/s
Flow rate 2 year (l/s)	<input type="text" value="6.4"/>	l/s
Flow rate 10 years (l/s)	<input type="text" value="9.5"/>	l/s
Flow rate 30 years (l/s)	<input type="text" value="11.7"/>	l/s
Flow rate 100 years (l/s)	<input type="text" value="14.3"/>	l/s
Flow rate 200 years (l/s)	<input type="text" value="16.3"/>	l/s

Disclaimer

This report was produced using the Greenfield runoff rate estimation tool (2.0.1) developed by HR Wallingford and available at uksuds.com (<https://www.uksuds.com/>).

The use of this tool is subject to the UK SuDS terms and conditions and licence agreement, which can both be found at [uksuds.com/terms-conditions](https://www.uksuds.com/terms-conditions) (<https://www.uksuds.com/terms-conditions>). The outputs from this tool have been used to estimate Greenfield runoff rates. The use of these results is the responsibility of the users of this tool. No liability will be accepted by HR Wallingford, the Environment Agency, Centre for Ecology and Hydrology, Wallingford

Hydrosolutions or any other organisation for the use of these data in the design or operational characteristics of any drainage scheme.

Appendix E

CIRIA SIA Tool - Pollution

SUMMARY TABLE		DESIGN CONDITIONS			
		1	2	3	4
Land Use Type	Standard commercial yard or delivery area				
Pollution Hazard Level	Medium	This classification is not appropriate for haulage yards, lorry parks, waste management areas, or chemical storage/handling zones			
Pollution Hazard Indices					
TSS	0.7				
Metals	0.6				
Hydrocarbons	0.7				
SuDS components proposed					
Component 1	Petrol interceptor (from SPEL) - Bypass	Detailed assessment of performance of designed component in reducing inflow concentrations of each pollutant type required as evidence of adopted indices. Enter indices approved by the environmental regulator in appropriate 'User Defined Indices' row below			
Component 2	None				
Component 3	None				
SuDS Pollution Mitigation Indices					
TSS		0.8			
Metals		0.6			
Hydrocarbons		0.9			
Groundwater protection type	None				
Groundwater protection Pollution Mitigation Indices					
TSS	0				
Metals	0				
Hydrocarbons	0				
Combined Pollution Mitigation Indices					
TSS		0.8			
Metals		0.6			
Hydrocarbons		0.9			
Acceptability of Pollution Mitigation		Reference to local planning documents should also be made to identify any additional protection required for sites due to habitat conservation (see Chapter 7 The SuDS design process). The implications of developments on or within close proximity to an area with an environmental designation, such as a Site of Special Scientific Interest (SSSI), should be considered via consultation with relevant conservation bodies such as Natural England			
TSS	Sufficient				
Metals	Sufficient				
Hydrocarbons	Sufficient				

Appendix F

InfoDrainage Model Results

Project: Alston Dairy	Date: 02/07/2025			
	Designed by: JR	Checked by: RG	Approved By: RG	
Report Details: Type: Inflows Storm Phase: Phase	Company Address: Pluviam Environmental			



Catchment Area

Type : Catchment Area

Area (ha)	0.025
-----------	-------

Dynamic Sizing

Runoff Method	Time of Concentration
Summer Volumetric Runoff	1.000
Winter Volumetric Runoff	1.000
Time of Concentration (mins)	5
Percentage Impervious (%)	90



Catchment Area (1)

Type : Catchment Area

Area (ha)	0.04
-----------	------

Dynamic Sizing

Runoff Method	Time of Concentration
Summer Volumetric Runoff	1.000
Winter Volumetric Runoff	1.000
Time of Concentration (mins)	5
Percentage Impervious (%)	90



Catchment Area (2)

Type : Catchment Area

Area (ha)	0.063
-----------	-------

Dynamic Sizing

Runoff Method	Time of Concentration
Summer Volumetric Runoff	1.000
Winter Volumetric Runoff	1.000
Time of Concentration (mins)	5
Percentage Impervious (%)	90



Catchment Area (3)

Type : Catchment Area

Area (ha)	0.084
-----------	-------

Dynamic Sizing

Runoff Method	Time of Concentration
Summer Volumetric Runoff	1.000
Winter Volumetric Runoff	1.000
Time of Concentration (mins)	5
Percentage Impervious (%)	90

Project: Alston Dairy	Date: 02/07/2025			
	Designed by: JR	Checked by: RG	Approved By: RG	
Report Details: Type: Inflows Storm Phase: Phase	Company Address: Pluviam Environmental			



Catchment Area (4)

Type : Catchment Area

Area (ha)	0.103
-----------	-------

Dynamic Sizing

Runoff Method	Time of Concentration
Summer Volumetric Runoff	1.000
Winter Volumetric Runoff	1.000
Time of Concentration (mins)	5
Percentage Impervious (%)	90



Catchment Area (5)

Type : Catchment Area

Area (ha)	0.026
-----------	-------

Dynamic Sizing

Runoff Method	Time of Concentration
Summer Volumetric Runoff	1.000
Winter Volumetric Runoff	1.000
Time of Concentration (mins)	5
Percentage Impervious (%)	90



Catchment Area (6)

Type : Catchment Area

Area (ha)	0.014
-----------	-------

Dynamic Sizing

Runoff Method	Time of Concentration
Summer Volumetric Runoff	1.000
Winter Volumetric Runoff	1.000
Time of Concentration (mins)	5
Percentage Impervious (%)	90



Catchment Area (7)

Type : Catchment Area

Area (ha)	0.027
-----------	-------

Dynamic Sizing

Runoff Method	Time of Concentration
Summer Volumetric Runoff	1.000
Winter Volumetric Runoff	1.000
Time of Concentration (mins)	5
Percentage Impervious (%)	90

Project: Alston Dairy	Date: 02/07/2025			
	Designed by: JR	Checked by: RG	Approved By: RG	
Report Details: Type: Inflows Storm Phase: Phase	Company Address: Pluviam Environmental			



Catchment Area (8)

Type : Catchment Area

Area (ha)	0.02
-----------	------

Dynamic Sizing

Runoff Method	Time of Concentration
Summer Volumetric Runoff	1.000
Winter Volumetric Runoff	1.000
Time of Concentration (mins)	5
Percentage Impervious (%)	90



Catchment Area (9)

Type : Catchment Area

Area (ha)	0.082
-----------	-------

Dynamic Sizing

Runoff Method	Time of Concentration
Summer Volumetric Runoff	1.000
Winter Volumetric Runoff	1.000
Time of Concentration (mins)	5
Percentage Impervious (%)	90



Catchment Area (10)

Type : Catchment Area

Area (ha)	0.014
-----------	-------

Dynamic Sizing

Runoff Method	Time of Concentration
Summer Volumetric Runoff	1.000
Winter Volumetric Runoff	1.000
Time of Concentration (mins)	5
Percentage Impervious (%)	90



Catchment Area (11)

Type : Catchment Area

Area (ha)	0.008
-----------	-------

Dynamic Sizing

Runoff Method	Time of Concentration
Summer Volumetric Runoff	1.000
Winter Volumetric Runoff	1.000
Time of Concentration (mins)	5
Percentage Impervious (%)	90

Project: Alston Dairy	Date: 02/07/2025			
	Designed by: JR	Checked by: RG	Approved By: RG	
Report Details: Type: Inflows Storm Phase: Phase	Company Address: Pluviam Environmental			



Catchment Area (12)

Type : Catchment Area

Area (ha)	0.015
-----------	-------

Dynamic Sizing

Runoff Method	Time of Concentration
Summer Volumetric Runoff	1.000
Winter Volumetric Runoff	1.000
Time of Concentration (mins)	5
Percentage Impervious (%)	90



Catchment Area (13)

Type : Catchment Area

Area (ha)	0.017
-----------	-------

Dynamic Sizing

Runoff Method	Time of Concentration
Summer Volumetric Runoff	1.000
Winter Volumetric Runoff	1.000
Time of Concentration (mins)	5
Percentage Impervious (%)	100



Catchment Area (14)

Type : Catchment Area

Area (ha)	0.014
-----------	-------

Dynamic Sizing

Runoff Method	Time of Concentration
Summer Volumetric Runoff	1.000
Winter Volumetric Runoff	1.000
Time of Concentration (mins)	5
Percentage Impervious (%)	90



Catchment Area (15)

Type : Catchment Area

Area (ha)	0.013
-----------	-------

Dynamic Sizing

Runoff Method	Time of Concentration
Summer Volumetric Runoff	1.000
Winter Volumetric Runoff	1.000
Time of Concentration (mins)	5
Percentage Impervious (%)	0.9

Project: Alston Dairy	Date: 02/07/2025		
	Designed by: JR	Checked by: RG	Approved By: RG
Report Details: Type: Junctions Storm Phase: Phase	Company Address: Pluviam Environmental		



Name	Junction Type	Easting (m)	Northing (m)	Cover Level (m)	Depth (m)	Invert Level (m)	Chamber Shape	Diameter (m)
SW8	Manhole	1915.827	-747.865	79.200	1.871	77.329	Circular	1.200
SW9	Manhole	1877.389	-747.689	78.913	1.755	77.158	Circular	1.200
SW10	Manhole	1876.840	-771.367	78.619	1.625	76.995	Circular	1.200
SW11	Manhole	1873.297	-774.611	78.478	1.525	76.953	Circular	1.200
SW12	Manhole	1863.265	-775.022	78.508	1.717	76.791	Circular	1.200
SW13	Manhole	1862.852	-795.561	77.950	1.251	76.699	Circular	1.200
SW1	Manhole	1925.683	-775.687	78.681	0.925	77.756	Circular	1.200
SW2	Manhole	1923.333	-747.785	79.235	1.604	77.632	Circular	1.200
SW3	Manhole	1911.975	-742.428	79.219	1.755	77.464	Circular	1.200
SW4	Manhole	1880.542	-729.045	79.021	1.709	77.312	Circular	1.200
SW5	Manhole	1860.318	-767.803	78.584	1.584	77.000	Circular	1.350
SW6	Manhole	1844.941	-796.822	78.714	1.859	76.854	Circular	1.350
SW14	Manhole	1843.328	-820.963	77.930	2.654	75.277	Circular	1.350
SW7	Manhole	1915.402	-802.482	78.566	0.850	77.716	Circular	1.200

Name	Lock
SW8	None
SW9	None
SW10	None
SW11	None
SW12	None
SW13	None
SW1	None
SW2	None
SW3	None
SW4	None
SW5	None
SW6	None
SW14	None
SW7	None

Project: Alston Dairy	Date: 02/07/2025		
	Designed by: JR	Checked by: RG	Approved By: RG
Report Details: Type: Junctions Storm Phase: Phase	Company Address: Pluviam Environmental		



Inlets

Junction	Inlet Name	Incoming Item(s)	Bypass Destination	Capacity Type
SW8	Inlet	Catchment Area (4)	(None)	No Restriction
	Inlet (1)	4.000	(None)	No Restriction
SW9	Inlet	Catchment Area (7) 4.001	(None)	No Restriction
SW10	Inlet	Catchment Area (8) 4.002	(None)	No Restriction
SW11	Inlet	4.003	(None)	No Restriction
SW12	Inlet	4.004	(None)	No Restriction
SW13	Inlet	Catchment Area (9) 4.005	(None)	No Restriction
SW1	Inlet	Catchment Area (3)	(None)	No Restriction
SW2	Inlet	1.000 2.000	(None)	No Restriction
	Inlet (1)	No Delay	(None)	No Restriction
SW3	Inlet	Catchment Area (2) 1.001 3.000	(None)	No Restriction
	Inlet (2)	5.000	(None)	No Restriction
SW4	Inlet	Catchment Area (6) 1.002	(None)	No Restriction
	Inlet (1)	Catchment Area (11)	(None)	No Restriction
	Inlet (2)	6.000	(None)	No Restriction
SW5	Inlet	1.003	(None)	No Restriction
	Inlet (2)	7.000	(None)	No Restriction
SW6	Inlet	1.004 Catchment Area (15)	(None)	No Restriction
SW14	Inlet	1.006	(None)	No Restriction

Outlets

Junction	Outlet Name	Outgoing Connection	Outlet Type
SW8	Outlet	4.001	Free Discharge
SW9	Outlet	4.002	Free Discharge
SW10	Outlet	4.003	Free Discharge
SW11	Outlet	4.004	Free Discharge
SW12	Outlet	4.005	Free Discharge
SW13	Outlet	4.006	Free Discharge
SW1	Outlet	1.000	Free Discharge
SW2	Outlet	1.001	Free Discharge
SW3	Outlet	1.002	Free Discharge
SW4	Outlet	1.003	Free Discharge
SW5	Outlet	1.004	Free Discharge
SW6	Outlet	1.005	Free Discharge
SW7	Outlet	4.000	Free Discharge

Project: Alston Dairy	Date: 02/07/2025			
	Designed by: JR	Checked by: RG	Approved By: RG	
Report Details: Type: Stormwater Controls Storm Phase: Phase	Company Address: Pluviam Environmental			



Bioretention 1

Type : Bioretention

Ponding Area

Exceedance Level (m)	78.829
Depth (m)	0.150
Base Level (m)	78.679
Top Area (m ²)	79.41
Side Slope (1:X)	2.00
Base Area (m ²)	64.83
Freeboard (mm)	150
Porosity (%)	100
Length (m)	24.298
Long. Slope (1:X)	1000.00
Filtration Rate (m/hr)	5.0
Friction Scheme	Manning's n
n	0.03
Total Volume (m ³)	13.748

Filter Area

Base Level (m)	77.879
----------------	--------

Under Drain

Height Above Base (m)	0.050
Diameter (mm)	100
No. of Barrels	1
Friction Scheme	Manning's n
n	0.015
Release Height (m)	0.000

Filtration Layers

Use	Name	Filtration Layer Depth (mm)	Porosity (%)	Conductivity (m/hr)	Soil Type
<input checked="" type="checkbox"/>	Soil	600	25	0.3	Soil Type
	Storage	200	30	5.0	

Inlets

Inlet

Inlet Type	Lateral Inflow
Incoming Item(s)	Catchment Area (5)
Bypass Destination	(None)
Inlet Destination	Ponding Area
Capacity Type	No Restriction

Outlets

Outlet

Outgoing Connection	No Delay
Outlet Type	Under Drain

Project: Alston Dairy	Date: 02/07/2025			
	Designed by: JR	Checked by: RG	Approved By: RG	
Report Details: Type: Stormwater Controls Storm Phase: Phase	Company Address: Pluviam Environmental			

Advanced

Ponding Area

Base Perimeter (m)	53.932
Top Perimeter (m)	55.132



Bioretention 2

Type : Bioretention

Ponding Area

Exceedance Level (m)	79.021
Depth (m)	0.150
Base Level (m)	78.871
Top Area (m ²)	28.00
Side Slope (1:X)	2.00
Base Area (m ²)	18.004
Freeboard (mm)	150
Porosity (%)	100
Length (m)	16.660
Long. Slope (1:X)	1000.00
Filtration Rate (m/hr)	5.0
Friction Scheme	Manning's n
n	0.03
Total Volume (m ³)	3.872

Filter Area

Base Level (m)	78.071
----------------	--------

Under Drain

Height Above Base (m)	0.050
Diameter (mm)	100
No. of Barrels	1
Friction Scheme	Manning's n
n	0.015
Release Height (m)	0.000

Filtration Layers

Use	Name	Filtration Layer Depth (mm)	Porosity (%)	Conductivity (m/hr)	Soil Type
<input checked="" type="checkbox"/>	Soil	600	25	0.3	Soil Type
	Storage	200	30	5.0	

Inlets

Inlet

Inlet Type	Lateral Inflow
Incoming Item(s)	Catchment Area (12)
Bypass Destination	(None)
Inlet Destination	Ponding Area
Capacity Type	No Restriction

Project: Alston Dairy	Date: 02/07/2025			
	Designed by: JR	Checked by: RG	Approved By: RG	
Report Details: Type: Stormwater Controls Storm Phase: Phase	Company Address: Pluviam Environmental			

Outlets

Outlet

Outgoing Connection	5.000
Outlet Type	Under Drain

Advanced

Ponding Area

Base Perimeter (m)	35.481
Top Perimeter (m)	36.681



Bioretention 3

Type : Bioretention

Ponding Area

Exceedance Level (m)	78.942
Depth (m)	0.150
Base Level (m)	78.792
Top Area (m ²)	20.93
Side Slope (1:X)	2.00
Base Area (m ²)	16.27
Freeboard (mm)	150
Porosity (%)	100
Length (m)	7.763
Long. Slope (1:X)	1000.00
Filtration Rate (m/hr)	5.0
Friction Scheme	Manning's n
n	0.03
Total Volume (m ³)	3.459

Filter Area

Base Level (m)	77.992
----------------	--------

Under Drain

Height Above Base (m)	0.050
Diameter (mm)	100
No. of Barrels	1
Friction Scheme	Manning's n
n	0.015
Release Height (m)	0.000

Filtration Layers

Use	Name	Filtration Layer Depth (mm)	Porosity (%)	Conductivity (m/hr)	Soil Type
<input checked="" type="checkbox"/>	Soil	600	25	0.3	Soil Type
	Storage	200	30	5.0	

Project: Alston Dairy	Date: 02/07/2025			
	Designed by: JR	Checked by: RG	Approved By: RG	
Report Details: Type: Stormwater Controls Storm Phase: Phase	Company Address: Pluviam Environmental			

Inlets

Inlet

Inlet Type	Lateral Inflow
Incoming Item(s)	Catchment Area (14)
Bypass Destination	(None)
Inlet Destination	Ponding Area
Capacity Type	No Restriction

Outlets

Outlet

Outgoing Connection	6.000
Outlet Type	Under Drain

Advanced

Ponding Area

Base Perimeter (m)	19.718
Top Perimeter (m)	20.918



Bioretention 4

Type : Bioretention

Project: Alston Dairy	Date: 02/07/2025		
	Designed by: JR	Checked by: RG	Approved By: RG
Report Details: Type: Stormwater Controls Storm Phase: Phase	Company Address: Pluviam Environmental		



Ponding Area

Exceedance Level (m)	78.518
Depth (m)	0.150
Base Level (m)	78.368
Top Area (m ²)	37.08
Side Slope (1:X)	2.00
Base Area (m ²)	29.33
Freeboard (mm)	150
Porosity (%)	100
Length (m)	12.910
Long. Slope (1:X)	1000.00
Filtration Rate (m/hr)	5.0
Friction Scheme	Manning's n
n	0.03
Total Volume (m ³)	6.230

Filter Area

Base Level (m)	77.568
----------------	--------

Under Drain

Height Above Base (m)	0.050
Diameter (mm)	100
No. of Barrels	1
Friction Scheme	Manning's n
n	0.015
Release Height (m)	0.000

Filtration Layers

Use	Name	Filtration Layer Depth (mm)	Porosity (%)	Conductivity (m/hr)	Soil Type
<input checked="" type="checkbox"/>	Soil	600	25	0.3	Soil Type
	Storage	200	30	5.0	

Inlets

Inlet

Inlet Type	Lateral Inflow
Incoming Item(s)	Catchment Area (13)
Bypass Destination	(None)
Inlet Destination	Ponding Area
Capacity Type	No Restriction

Outlets

Outlet

Outgoing Connection	7.000
Outlet Type	Under Drain

Advanced

Ponding Area

Base Perimeter (m)	30.364
Top Perimeter (m)	31.564

Project: Alston Dairy	Date: 02/07/2025		
	Designed by: JR	Checked by: RG	Approved By: RG
Report Details: Type: Stormwater Controls Storm Phase: Phase	Company Address: Pluviam Environmental		



Tank

Type : Tank

Dimensions

Exceedance Level (m)	77.885
Depth (m)	2.485
Base Level (m)	75.400
Freeboard (mm)	900
Initial Depth (m)	0.000
Porosity (%)	97
Average Slope (1:X)	0.00
Total Volume (m³)	322.830

Depth (m)	Area (m²)	Volume (m³)
0.000	210.00	0.000
1.680	210.00	342.216

Inlets

Inlet

Inlet Type	Point Inflow
Incoming Item(s)	1.005
Bypass Destination	(None)
Capacity Type	No Restriction

Inlet (1)

Inlet Type	Point Inflow
Incoming Item(s)	4.006
Bypass Destination	No Delay (1)
Capacity Type	(None)
	No Restriction

Project: Alston Dairy	Date: 02/07/2025		
	Designed by: JR	Checked by: RG	Approved By: RG
Report Details: Type: Stormwater Controls Storm Phase: Phase	Company Address: Pluviam Environmental		



Outlets

Outlet

Outgoing Connection	1.006
Outlet Type	Hydro-Brake®
Invert Level (m)	75.400
Design Depth (m)	1.680
Design Flow (L/s)	6.9
Objective	Minimise Upstream Storage Requirements
Application	Surface Water Only
Sump Available	<input checked="" type="checkbox"/>

Unit Reference	SHE-0113-6900-1680-6900
----------------	-------------------------

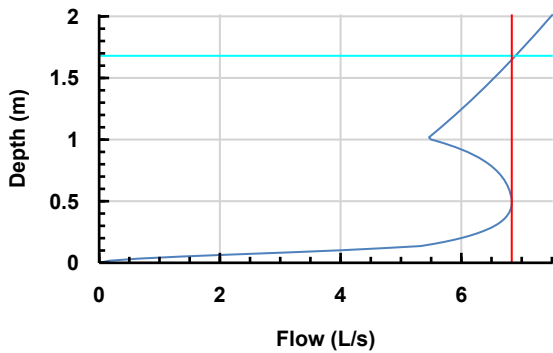

Advanced

Perimeter	Circular
Length (m)	6.031

Project: Alston Dairy	Date: 02/07/2025			
	Designed by: JR	Checked by: RG	Approved By: RG	
Report Details: Type: Stormwater Controls Storm Phase: Phase	Company Address: Pluviam Environmental			



Porous Paving

Type : Porous Paving

Dimensions

Exceedance Level (m)	78.187
Depth (m)	0.500
Base Level (m)	77.687
Paving Layer Depth (mm)	130
Membrane Percolation (m/hr)	100.0
Porosity (%)	30
Length (m)	6.642
Long. Slope (1:X)	1000.00
Width (m)	16.605
Total Volume (m³)	12.242

Inlets

Inlet

Inlet Type	Lateral Inflow
Incoming Item(s)	Catchment Area (10)
Bypass Destination	(None)
Capacity Type	No Restriction

Outlets

Outlet

Outgoing Connection	No Delay (1)
Outlet Type	Orifice
Diameter (m)	0.060
Coefficient of Discharge	0.600
Invert Level (m)	77.687

Advanced

Conductivity (m/hr)	5.0
---------------------	-----

Project: Alston Dairy	Date: 02/07/2025		
	Designed by: JR	Checked by: RG	Approved By: RG
Report Details: Type: Stormwater Controls Storm Phase: Phase	Company Address: Pluviam Environmental		



Dry Swale 1

Type : Swale

Swale

Exceedance Level (m)	78.955
Depth (m)	0.400
Base Level (m)	78.555
Top Width (m)	2.871
Side Slope (1:X)	3.00
Base Width (m)	0.471
Freeboard (mm)	400
Length (m)	16.027
Long. Slope (1:X)	1000.00
Filtration Rate (m/hr)	0.0
Friction Scheme	Manning's n
n	0.03
Total Volume (m³)	0.000

Inlets

Inlet

Inlet Type	Lateral Inflow
Incoming Item(s)	Catchment Area
Bypass Destination	(None)
Inlet Destination	Ponding Area
Capacity Type	No Restriction

Outlets

Outlet

Outgoing Connection	3.000
Outlet Type	Orifice
Diameter (m)	0.050
Coefficient of Discharge	0.600
Invert Level (m)	78.555

Advanced

Swale

Porosity (%)	100
--------------	-----

Project: Alston Dairy	Date: 02/07/2025			
	Designed by: JR	Checked by: RG	Approved By: RG	
Report Details: Type: Stormwater Controls Storm Phase: Phase	Company Address: Pluviam Environmental			



Dry Swale 2

Type : Swale

Swale

Exceedance Level (m)	79.253
Depth (m)	0.400
Base Level (m)	78.853
Top Width (m)	2.903
Side Slope (1:X)	3.00
Base Width (m)	0.503
Freeboard (mm)	400
Length (m)	16.230
Long. Slope (1:X)	200.00
Filtration Rate (m/hr)	5.0
Friction Scheme	Manning's n
n	0.03
Total Volume (m³)	0.000

Inlets

Inlet

Inlet Type	Point Inflow
Incoming Item(s)	Catchment Area (1)
Bypass Destination	(None)
Inlet Destination	Ponding Area
Capacity Type	No Restriction

Outlets

Outlet

Outgoing Connection	2.000
Outlet Type	Orifice
Diameter (m)	0.100
Coefficient of Discharge	0.600
Invert Level (m)	78.853

Advanced

Swale

Porosity (%)	100
--------------	-----

Project: Alston Dairy	Date: 02/07/2025		
	Designed by: JR	Checked by: RG	Approved By: RG
Report Details: Type: Connections Storm Phase: Phase	Company Address: Pluviam Environmental		



Name	Length (m)	Connection Type	Slope (1:X)	Manning's n	Colebrook-White Roughness (mm)	Diameter / Base Width (mm)	Upstream	Upstream Invert Level (m)
4.001	38.438	Pipe	225.000		0.6	225	79.200	77.329
4.002	23.685	Pipe	145.000		0.6	225	78.913	77.158
4.003	4.804	Pipe	115.000		0.6	225	78.619	76.995
4.004	10.040	Pipe	115.000		0.6	225	78.478	76.953
4.005	20.544	Pipe	225.000		0.6	300	78.508	76.791
1.000	28.001	Pipe	225.000		0.6	225	78.681	77.756
1.001	12.558	Pipe	74.739		0.6	225	79.235	77.632
1.002	34.164	Pipe	225.000		0.6	300	79.219	77.464
1.003	43.718	Pipe	140.430		0.6	300	79.021	77.312
1.004	32.841	Pipe	225.000		0.6	375	78.584	77.000
1.005	5.243	Pipe	3.605		0.6	375	78.714	76.854
2.000	5.623	No Delay						
3.000	10.919	No Delay						
1.006	18.486	Pipe	150.000		0.6	150	78.651	75.400
4.006	23.923	Pipe	225.000		0.6	300	77.950	76.699
4.000	54.619	Pipe	150.000		0.6	150	78.566	77.716
No Delay	13.911	No Delay						
No Delay (1)	15.978	No Delay						
5.000	9.899	No Delay						
6.000	11.237	No Delay						
7.000	8.092	No Delay						

Name	Downstream Cover Level (m)	Downstream Invert Level (m)	Part Family	Lock	Flow Restriction (L/s)	Culvert Type	Culvert Entrance
4.001	78.913	77.158		None		(None)	(None)
4.002	78.619	76.995		None		(None)	(None)
4.003	78.478	76.953		None		(None)	(None)
4.004	78.508	76.866		None		(None)	(None)
4.005	77.950	76.699		None		(None)	(None)
1.000	79.235	77.632		None		(None)	(None)
1.001	79.219	77.464		None		(None)	(None)
1.002	79.021	77.312		None		(None)	(None)
1.003	78.584	77.000		None		(None)	(None)
1.004	78.714	76.854		None		(None)	(None)
1.005	78.674	75.400		None		(None)	(None)
2.000							
3.000							
1.006	77.930	75.277		All	6.7	(None)	(None)
4.006	78.648	76.593		Levels		(None)	(None)
4.000	79.200	77.352		None		(None)	(None)
No Delay							
No Delay (1)							
5.000							
6.000							
7.000							

Project: Alston Dairy	Date: 02/07/2025		
	Designed by: JR	Checked by: RG	Approved By: RG
Report Details: Type: Manhole Schedule Storm Phase: Phase	Company Address: Pluviam Environmental		



Name	Cover Level (m) Invert Level (m)	Manhole Size (m)	Connection Details				Type
Coordinates (m)	Depth (m)		Incoming Connections	Connection Type	Connection Invert (m)	Connection Size (mm)	Junction Type Cover
SW8	79.200 77.329	Diameter / Length: 1.200	{1} 4.000	Pipe	77.352	Diam/Width:150	Manhole
E:1915.827 N:-747.865	1.871		{a} 4.001	Pipe	77.329	Diam/Width:225	Not Applicable
SW9	78.913 77.158	Diameter / Length: 1.200	{1} 4.001	Pipe	77.158	Diam/Width:225	Manhole
E:1877.389 N:-747.689	1.755		{a} 4.002	Pipe	77.158	Diam/Width:225	Not Applicable
SW10	78.619 76.995	Diameter / Length: 1.200	{1} 4.002	Pipe	76.995	Diam/Width:225	Manhole
E:1876.840 N:-771.367	1.625		{a} 4.003	Pipe	76.995	Diam/Width:225	Not Applicable
SW11	78.478 76.953	Diameter / Length: 1.200	{1} 4.003	Pipe	76.953	Diam/Width:225	Manhole
E:1873.297 N:-774.611	1.525		{a} 4.004	Pipe	76.953	Diam/Width:225	Not Applicable
SW12	78.508 76.791	Diameter / Length: 1.200	{1} 4.004	Pipe	76.866	Diam/Width:225	Manhole
E:1863.265 N:-775.022	1.717		{a} 4.005	Pipe	76.791	Diam/Width:300	Not Applicable
SW13	77.950 76.699	Diameter / Length: 1.200	{1} 4.005	Pipe	76.699	Diam/Width:300	Manhole
E:1862.852 N:-795.561	1.251		{a} 4.006	Pipe	76.699	Diam/Width:300	Not Applicable

Project: Alston Dairy	Date: 02/07/2025			
	Designed by: JR	Checked by: RG	Approved By: RG	
Report Details: Type: Manhole Schedule Storm Phase: Phase	Company Address: Pluviam Environmental			

Name	Cover Level (m) Invert Level (m)	Manhole Size (m)	Connection Details				Type
			Incoming Connections	Connection Type	Connection Invert (m)	Connection Size (mm)	Junction Type
Coordinates (m)	Depth (m)		Outgoing Connections				Cover
SW1	78.681 77.756	Diameter / Length: 1.200					Manhole
E:1925.683 N:-775.687	0.925		{a} 1.000	Pipe	77.756	Diam/Width:225	Not Applicable
SW2	79.235 77.632	Diameter / Length: 1.200	{1} 1.000	Pipe	77.632	Diam/Width:225	Manhole
E:1923.333 N:-747.785	1.604		{2} 2.000	No Delay	Not Applicable	Not Applicable	
			{3} No Delay	No Delay	Not Applicable		
			{a} 1.001	Pipe	77.632	Diam/Width:225	Not Applicable
SW3	79.219 77.464	Diameter / Length: 1.200	{1} 1.001	Pipe	77.464	Diam/Width:225	Manhole
E:1911.975 N:-742.428	1.755		{2} 3.000	No Delay	Not Applicable	Not Applicable	
			{3} 5.000	No Delay	Not Applicable		
			{a} 1.002	Pipe	77.464	Diam/Width:300	Not Applicable
SW4	79.021 77.312	Diameter / Length: 1.200	{1} 1.002	Pipe	77.312	Diam/Width:300	Manhole
E:1880.542 N:-729.045	1.709		{2} 6.000	No Delay	Not Applicable		
			{a} 1.003	Pipe	77.312	Diam/Width:300	Not Applicable

Project: Alston Dairy	Date: 02/07/2025		
	Designed by: JR	Checked by: RG	Approved By: RG
Report Details: Type: Manhole Schedule Storm Phase: Phase	Company Address: Pluviam Environmental		



Name	Cover Level (m) Invert Level (m)	Manhole Size (m)	Connection Details				Type
Coordinates (m)	Depth (m)		Incoming Connections	Connection Type	Connection Invert (m)	Connection Size (mm)	Junction Type Cover
SW5	78.584 77.000	Diameter / Length: 1.350	{1} 1.003	Pipe	77.000	Diam/Width:300	Manhole
E:1860.318 N:-767.803	1.584		{2} 7.000	No Delay	Not Applicable	Not Applicable	
			{a} 1.004	Pipe	77.000	Diam/Width:375	Not Applicable
SW6	78.714 76.854	Diameter / Length: 1.350	{1} 1.004	Pipe	76.854	Diam/Width:375	Manhole
E:1844.941 N:-796.822	1.859		{a} 1.005	Pipe	76.854	Diam/Width:375	Not Applicable
SW14	77.930 75.277	Diameter / Length: 1.350	{1} 1.006	Pipe	75.277	Diam/Width:150	Manhole
E:1843.328 N:-820.963	2.654						Not Applicable
SW7	78.566 77.716	Diameter / Length: 1.200					Manhole
E:1915.402 N:-802.482	0.850		{a} 4.000	Pipe	77.716	Diam/Width:150	Not Applicable

Project: Alston Dairy	Date: 02/07/2025		
	Designed by: JR	Checked by: RG	Approved By: RG
Report Details: Type: Inflow Summary Storm Phase: Phase	Company Address: Pluviam Environmental		



Inflow Label	Connected To	Flow (L/s)	Runoff Method	Area (ha)	Percentage Impervious (%)	Urban Creep (%)	Adjusted Percentage Impervious (%)	Area Analysed (ha)
Catchment Area	Dry Swale 1		Time of Concentration	0.025	90.0	0	90.0	0.023
Catchment Area (1)	Dry Swale 2		Time of Concentration	0.040	90.0	0	90.0	0.036
Catchment Area (2)	SW3		Time of Concentration	0.063	90.0	0	90.0	0.057
Catchment Area (3)	SW1		Time of Concentration	0.084	90.0	0	90.0	0.076
Catchment Area (4)	SW8		Time of Concentration	0.103	90.0	0	90.0	0.092
Catchment Area (5)	Bioretention 1		Time of Concentration	0.026	90.0	0	90.0	0.023
Catchment Area (6)	SW4		Time of Concentration	0.014	90.0	0	90.0	0.012
Catchment Area (7)	SW9		Time of Concentration	0.027	90.0	0	90.0	0.024
Catchment Area (8)	SW10		Time of Concentration	0.020	90.0	0	90.0	0.018
Catchment Area (9)	SW13		Time of Concentration	0.082	90.0	0	90.0	0.073
Catchment Area (10)	Porous Paving		Time of Concentration	0.014	90.0	0	90.0	0.012
Catchment Area (11)	SW4		Time of Concentration	0.008	90.0	0	90.0	0.007
Catchment Area (12)	Bioretention 2		Time of Concentration	0.015	90.0	0	90.0	0.014
Catchment Area (13)	Bioretention 4		Time of Concentration	0.017	100.0	0	100.0	0.017
Catchment Area (14)	Bioretention 3		Time of Concentration	0.014	90.0	0	90.0	0.013
Catchment Area (15)	SW6		Time of Concentration	0.013	0.9	0	0.9	0.000
TOTAL		0.0		0.563				0.496

Project: Alston Dairy	Date: 02/07/2025		
	Designed by: JR	Checked by: RG	Approved By: RG
Report Details: Type: Network Design Criteria Storm Phase: Phase	Company Address: Pluviam Environmental		



Flow Options

Peak Flow Calculation	(UK) Modified Rational Method
Min. Time of Entry (mins)	5
Max. Travel Time (mins)	30

FEH

Type: FEH

Site Location	GB 360163 435444 SD 60163 35444
Return Period (years)	30.0
Rainfall Version	2022

Pipe Options

Lock Slope Options	None
Design Options	Minimise Excavation
Design Level	Level Soffits
Min. Cover Depth (m)	0.700
Min. Slope (1:X)	225.00
Max. Slope (1:X)	40.00
Min. Backdrop (m)	0.300
Max. Backdrop (m)	2.000
Min. Velocity (m/s)	0.75
Max. Velocity (m/s)	3.0
Use Flow Restriction	<input type="checkbox"/>
Reduce Channel Depths	<input type="checkbox"/>

Pipe Size Library

Default

Add. Increment (mm)	75
Max. Diameter (mm)	0

Diameter (mm)	Min. Slope (1:X)	Max. Slope (1:X)
100	0.00	0.00
150	0.00	0.00

Project: Alston Dairy	Date: 02/07/2025		
	Designed by: JR	Checked by: RG	Approved By: RG
Report Details: Type: Network Design Criteria Storm Phase: Phase	Company Address: Pluviam Environmental		



Manhole Options

Apply Offset

Manhole Size Library

Default

Diameter / Width

Connection (mm)	Diameter / Length (m)	Width (m)
0	1.200	0.000
375	1.350	0.000
500	1.500	0.000
750	1.800	0.000

Additional Sizing

Connection (mm)	900
Diameter / Length (m)	0.900
Width (m)	0.000

Depth

Depth (m)	Diameter / Length (m)	Width (m)
0.000	1.050	0.000
1.500	1.200	0.000

Access

Depth (m)	Ladder Protrusion (mm)
0.000	130
3.000	230

Benching Requirements

Landing Width (mm)	500
Benching Width (mm)	225

Project: Alston Dairy	Date: 02/07/2025			
	Designed by: JR	Checked by: RG	Approved By: RG	
Report Details: Type: Outfall Details Storm Phase: Phase	Company Address: Pluviam Environmental			

Outfalls

Outfall	Outfall Type	Gated	Fixed Surcharged Level (m)	Level Curve
SW14	Free Discharge			

Project: Alston Dairy	Date: 02/07/2025			
	Designed by: JR	Checked by: RG	Approved By: RG	
Report Title: Rainfall Analysis Criteria	Company Address: Pluviam Environmental			

Runoff Type	Dynamic
Output Interval (mins)	5
Time Step	Default
Urban Creep	Apply Global Value
Urban Creep Global Value (%)	0
Junction Flood Risk Margin (mm)	300
Perform No Discharge Analysis	<input type="checkbox"/>

Project: Alston Dairy	Date: 02/07/2025		
	Designed by: JR	Checked by: RG	Approved By: RG
Report Details: Type: Junctions Summary Storm Phase: Phase	Company Address: Pluviam Environmental		



FEH: 2 years: Increase Rainfall (%): +0: Critical Storm Per Item: Rank By: Max. Flooded Volume

Junction	Storm Event	Cover Level (m)	Invert Level (m)	Max. Level (m)	Max. Depth (m)	Max. Inflow (L/s)	Max. Resident Volume (m³)	Max. Flooded Volume (m³)	Max. Outflow (L/s)	Total Discharge Volume (m³)	Status
SW8	FEH: 2 years: +0 %: 15 mins: Summer	79.20 0	77.32 9	77.439	0.110	17.1	0.124	0.000	15.4	7.430	OK
SW9	FEH: 2 years: +0 %: 15 mins: Summer	78.91 3	77.15 8	77.267	0.109	19.8	0.123	0.000	18.2	9.336	OK
SW10	FEH: 2 years: +0 %: 15 mins: Summer	78.61 9	76.99 5	77.113	0.118	21.4	0.134	0.000	20.3	10.738	OK
SW11	FEH: 2 years: +0 %: 15 mins: Summer	78.47 8	76.95 3	77.062	0.109	20.3	0.123	0.000	19.4	10.722	OK
SW12	FEH: 2 years: +0 %: 15 mins: Summer	78.50 8	76.79 1	76.897	0.107	19.4	0.121	0.000	18.4	10.696	OK
SW13	FEH: 2 years: +0 %: 15 mins: Summer	77.95 0	76.69 9	76.839	0.139	32.1	0.158	0.000	28.6	16.569	OK
SW1	FEH: 2 years: +0 %: 15 mins: Summer	78.68 1	77.75 6	77.858	0.102	14.1	0.115	0.000	13.4	6.107	OK
SW2	FEH: 2 years: +0 %: 15 mins: Summer	79.23 5	77.63 2	77.719	0.087	17.6	0.099	0.000	16.7	8.945	OK
SW3	FEH: 2 years: +0 %: 15 mins: Summer	79.21 9	77.46 4	77.595	0.131	28.3	0.148	0.000	26.6	15.203	OK
SW4	FEH: 2 years: +0 %: 15 mins: Summer	79.02 1	77.31 2	77.428	0.116	30.2	0.131	0.000	27.4	16.906	OK
SW5	FEH: 2 years: +0 %: 15 mins: Summer	78.58 4	77.00 0	77.117	0.116	27.4	0.166	0.000	24.4	16.784	OK
SW6	FEH: 2 years: +0 %: 15 mins: Summer	78.71 4	76.85 4	76.896	0.042	24.4	0.060	0.000	24.0	16.763	OK
SW14	FEH: 2 years: +0 %: 15 mins: Summer	77.93 0	75.27 7	75.328	0.051	3.6	0.000	0.000	3.6	3.453	OK
SW7	FEH: 2 years: +0 %: 15 mins: Summer	78.56 6	77.71 6	77.716	0.000	0.0	0.000	0.000	0.0	0.000	OK

Project: Alston Dairy	Date: 02/07/2025		
	Designed by: JR	Checked by: RG	Approved By: RG
Report Details: Type: Junctions Summary Storm Phase: Phase	Company Address: Pluviam Environmental		



FEH: 30 years: Increase Rainfall (%): +0: Critical Storm Per Item: Rank By: Max. Flooded Volume

Junction	Storm Event	Cover Level (m)	Invert Level (m)	Max. Level (m)	Max. Depth (m)	Max. Inflow (L/s)	Max. Resident Volume (m³)	Max. Flooded Volume (m³)	Max. Outflow (L/s)	Total Discharge Volume (m³)	Status
SW8	FEH: 30 years: +0 %: 15 mins: Summer	79.20 0	77.32 9	77.521	0.192	36.9	0.217	0.000	33.3	15.990	OK
SW9	FEH: 30 years: +0 %: 15 mins: Summer	78.91 3	77.15 8	77.350	0.192	42.9	0.217	0.000	38.9	20.137	OK
SW10	FEH: 30 years: +0 %: 15 mins: Summer	78.61 9	76.99 5	77.212	0.217	45.9	0.245	0.000	43.9	23.170	OK
SW11	FEH: 30 years: +0 %: 15 mins: Summer	78.47 8	76.95 3	77.139	0.186	43.9	0.211	0.000	42.2	23.153	OK
SW12	FEH: 30 years: +0 %: 15 mins: Summer	78.50 8	76.79 1	76.976	0.186	42.2	0.210	0.000	40.2	23.122	OK
SW13	FEH: 30 years: +0 %: 15 mins: Summer	77.95 0	76.69 9	76.934	0.235	69.6	0.265	0.000	63.7	35.821	OK
SW1	FEH: 30 years: +0 %: 15 mins: Summer	78.68 1	77.75 6	77.924	0.168	30.3	0.190	0.000	28.8	13.156	OK
SW2	FEH: 30 years: +0 %: 15 mins: Summer	79.23 5	77.63 2	77.770	0.138	35.6	0.156	0.000	34.1	19.635	OK
SW3	FEH: 30 years: +0 %: 15 mins: Summer	79.21 9	77.46 4	77.673	0.210	58.4	0.237	0.000	55.5	32.715	OK
SW4	FEH: 30 years: +0 %: 15 mins: Summer	79.02 1	77.31 2	77.496	0.185	63.2	0.209	0.000	58.6	36.736	OK
SW5	FEH: 30 years: +0 %: 15 mins: Summer	78.58 4	77.00 0	77.174	0.174	58.6	0.248	0.000	54.5	37.129	OK
SW6	FEH: 30 years: +0 %: 15 mins: Summer	78.71 4	76.85 4	76.914	0.060	54.6	0.086	0.000	54.0	37.090	OK
SW14	FEH: 30 years: +0 %: 15 mins: Summer	77.93 0	75.27 7	75.345	0.068	6.2	0.000	0.000	6.2	6.807	OK
SW7	FEH: 30 years: +0 %: 15 mins: Summer	78.56 6	77.71 6	77.716	0.000	0.0	0.000	0.000	0.0	0.000	OK

Project: Alston Dairy	Date: 02/07/2025		
	Designed by: JR	Checked by: RG	Approved By: RG
Report Details: Type: Junctions Summary Storm Phase: Phase	Company Address: Pluviam Environmental		



FEH: 30 years: Increase Rainfall (%): +40: Critical Storm Per Item: Rank By: Max. Flooded Volume

Junction	Storm Event	Cover Level (m)	Invert Level (m)	Max. Level (m)	Max. Depth (m)	Max. Inflow (L/s)	Max. Resident Volume (m³)	Max. Flooded Volume (m³)	Max. Outflow (L/s)	Total Discharge Volume (m³)	Status
SW8	FEH: 30 years: +40 %: 15 mins: Summer	79.20 0	77.32 9	77.885	0.557	51.6	0.629	0.000	42.0	22.930	Surcharged
SW9	FEH: 30 years: +40 %: 15 mins: Summer	78.91 3	77.15 8	77.611	0.453	55.4	0.512	0.000	50.4	28.210	Surcharged
SW10	FEH: 30 years: +40 %: 15 mins: Summer	78.61 9	76.99 5	77.343	0.348	60.3	0.394	0.000	56.7	32.468	Surcharged
SW11	FEH: 30 years: +40 %: 15 mins: Summer	78.47 8	76.95 3	77.237	0.284	56.7	0.321	0.000	54.0	32.449	Surcharged
SW12	FEH: 30 years: +40 %: 15 mins: Summer	78.50 8	76.79 1	77.049	0.258	54.0	0.292	0.000	48.8	32.431	OK
SW13	FEH: 30 years: +40 %: 15 mins: Summer	77.95 0	76.69 9	77.010	0.310	89.9	0.351	0.000	83.6	50.212	Surcharged
SW1	FEH: 30 years: +40 %: 15 mins: Summer	78.68 1	77.75 6	78.004	0.248	42.4	0.280	0.000	39.3	18.389	Surcharged
SW2	FEH: 30 years: +40 %: 15 mins: Summer	79.23 5	77.63 2	77.833	0.202	47.2	0.228	0.000	41.7	27.740	OK
SW3	FEH: 30 years: +40 %: 15 mins: Summer	79.21 9	77.46 4	77.731	0.268	75.3	0.303	0.000	73.3	45.163	OK
SW4	FEH: 30 years: +40 %: 15 mins: Summer	79.02 1	77.31 2	77.543	0.231	84.3	0.261	0.000	79.6	50.483	OK
SW5	FEH: 30 years: +40 %: 15 mins: Summer	78.58 4	77.00 0	77.206	0.206	79.6	0.294	0.000	75.3	50.944	OK
SW6	FEH: 30 years: +40 %: 15 mins: Summer	78.71 4	76.85 4	76.925	0.071	75.4	0.101	0.000	74.7	50.901	OK
SW14	FEH: 30 years: +40 %: 15 mins: Summer	77.93 0	75.27 7	75.347	0.070	6.6	0.000	0.000	6.6	7.641	OK
SW7	FEH: 30 years: +40 %: 15 mins: Summer	78.56 6	77.71 6	77.744	0.028	5.3	0.032	0.000	0.6	0.625	OK

Project: Alston Dairy	Date: 02/07/2025		
	Designed by: JR	Checked by: RG	Approved By: RG
Report Details: Type: Junctions Summary Storm Phase: Phase	Company Address: Pluviam Environmental		



FEH: 100 years: Increase Rainfall (%): +0: Critical Storm Per Item: Rank By: Max. Flooded Volume

Junction	Storm Event	Cover Level (m)	Invert Level (m)	Max. Level (m)	Max. Depth (m)	Max. Inflow (L/s)	Max. Resident Volume (m³)	Max. Flooded Volume (m³)	Max. Outflow (L/s)	Total Discharge Volume (m³)	Status
SW8	FEH: 100 years: +0 %: 15 mins: Summer	79.20 0	77.32 9	77.694	0.365	46.2	0.413	0.000	36.4	20.241	Surcharged
SW9	FEH: 100 years: +0 %: 15 mins: Summer	78.91 3	77.15 8	77.467	0.309	48.5	0.349	0.000	43.8	25.246	Surcharged
SW10	FEH: 100 years: +0 %: 15 mins: Summer	78.61 9	76.99 5	77.268	0.273	52.6	0.309	0.000	51.1	29.053	Surcharged
SW11	FEH: 100 years: +0 %: 15 mins: Summer	78.47 8	76.95 3	77.181	0.228	51.1	0.258	0.000	48.3	29.034	Surcharged
SW12	FEH: 100 years: +0 %: 15 mins: Summer	78.50 8	76.79 1	77.012	0.222	48.3	0.251	0.000	45.5	29.008	OK
SW13	FEH: 100 years: +0 %: 15 mins: Summer	77.95 0	76.69 9	76.977	0.278	82.3	0.314	0.000	77.2	44.925	OK
SW1	FEH: 100 years: +0 %: 15 mins: Summer	78.68 1	77.75 6	77.964	0.208	38.0	0.235	0.000	35.9	16.479	OK
SW2	FEH: 100 years: +0 %: 15 mins: Summer	79.23 5	77.63 2	77.798	0.166	43.4	0.188	0.000	41.0	24.786	OK
SW3	FEH: 100 years: +0 %: 15 mins: Summer	79.21 9	77.46 4	77.712	0.248	71.2	0.281	0.000	67.9	40.638	OK
SW4	FEH: 100 years: +0 %: 15 mins: Summer	79.02 1	77.31 2	77.526	0.214	77.6	0.243	0.000	72.4	45.480	OK
SW5	FEH: 100 years: +0 %: 15 mins: Summer	78.58 4	77.00 0	77.195	0.195	72.4	0.279	0.000	68.0	45.955	OK
SW6	FEH: 100 years: +0 %: 15 mins: Summer	78.71 4	76.85 4	76.921	0.067	68.0	0.096	0.000	67.3	45.913	OK
SW14	FEH: 100 years: +0 %: 15 mins: Summer	77.93 0	75.27 7	75.346	0.070	6.5	0.000	0.000	6.5	7.400	OK
SW7	FEH: 100 years: +0 %: 15 mins: Summer	78.56 6	77.71 6	77.728	0.012	0.0	0.014	0.000	0.2	0.247	OK

Project: Alston Dairy	Date: 02/07/2025		
	Designed by: JR	Checked by: RG	Approved By: RG
Report Details: Type: Junctions Summary Storm Phase: Phase	Company Address: Pluviam Environmental		



FEH: 100 years: Increase Rainfall (%): +50: Critical Storm Per Item: Rank By: Max. Flooded Volume

Junction	Storm Event	Cover Level (m)	Invert Level (m)	Max. Level (m)	Max. Depth (m)	Max. Inflow (L/s)	Max. Resident Volume (m³)	Max. Flooded Volume (m³)	Max. Outflow (L/s)	Total Discharge Volume (m³)	Status
SW8	FEH: 100 years: +50 %: 15 mins: Summer	79.20 0	77.32 9	78.377	1.048	69.3	1.186	0.000	49.3	31.683	Surcharged
SW9	FEH: 100 years: +50 %: 15 mins: Summer	78.91 3	77.15 8	78.004	0.846	67.3	0.957	0.000	59.9	37.901	Surcharged
SW10	FEH: 100 years: +50 %: 15 mins: Summer	78.61 9	76.99 5	77.641	0.646	73.2	0.731	0.000	68.2	43.623	Surcharged
SW11	FEH: 100 years: +50 %: 15 mins: Summer	78.47 8	76.95 3	77.488	0.535	68.2	0.605	0.000	64.2	43.604	Surcharged
SW12	FEH: 100 years: +50 %: 15 mins: Summer	78.50 8	76.79 1	77.270	0.479	64.2	0.542	0.000	61.3	43.600	Surcharged
SW13	FEH: 100 years: +50 %: 15 mins: Summer	77.95 0	76.69 9	77.185	0.486	116.5	0.549	0.000	113.4	67.482	Surcharged
SW1	FEH: 100 years: +50 %: 15 mins: Summer	78.68 1	77.75 6	78.416	0.660	56.9	0.747	0.000	50.4	24.671	Flood Risk
SW2	FEH: 100 years: +50 %: 15 mins: Summer	79.23 5	77.63 2	78.110	0.478	59.5	0.541	0.000	54.9	37.129	Surcharged
SW3	FEH: 100 years: +50 %: 15 mins: Summer	79.21 9	77.46 4	77.921	0.458	99.6	0.518	0.000	94.8	59.560	Surcharged
SW4	FEH: 100 years: +50 %: 15 mins: Summer	79.02 1	77.31 2	77.634	0.322	109.5	0.364	0.000	98.8	66.389	Surcharged
SW5	FEH: 100 years: +50 %: 15 mins: Summer	78.58 4	77.00 0	77.233	0.233	98.9	0.333	0.000	94.5	66.719	OK
SW6	FEH: 100 years: +50 %: 15 mins: Summer	78.71 4	76.85 4	76.934	0.080	94.6	0.114	0.000	93.9	66.668	OK
SW14	FEH: 100 years: +50 %: 15 mins: Summer	77.93 0	75.27 7	75.347	0.071	6.6	0.000	0.000	6.6	8.101	OK
SW7	FEH: 100 years: +50 %: 15 mins: Summer	78.56 6	77.71 6	78.215	0.499	10.0	0.565	0.000	9.2	1.757	Surcharged

Project: Alston Dairy	Date: 02/07/2025		
	Designed by: JR	Checked by: RG	Approved By: RG
Report Details: Type: Stormwater Controls Summary Storm Phase: Phase	Company Address: Pluviam Environmental		



FEH: 2 years: Increase Rainfall (%): +0: Critical Storm Per Item: Rank By: Max. Outflow

Stormwater Control	Storm Event	Max. US Depth (m)	Max. DS	Max. Inflow (L/s)	Max. Residant	Max. Flooded Volume (m³)	Max. Outflow (L/s)	Total Discharge Volume (m³)	Percentage Available (%)	Status
Dry Swale 1	FEH: 2 years: +0 %: 30 mins: Summer	0.085	0.101	2.8	1.121	0.000	1.4	2.406	0.000	Flood Risk
Dry Swale 2	FEH: 2 years: +0 %: 30 mins: Summer	0.034	0.094	4.5	0.711	0.000	4.3	3.861	0.000	Flood Risk
Bioretention 1	FEH: 2 years: +0 %: 480 mins: Summer	0.200	0.200	1.0	5.312	0.000	0.5	5.011	61.365	OK
Porous Paving	FEH: 2 years: +0 %: 240 mins: Summer	0.095	0.046	0.8	2.044	0.000	0.2	1.587	83.307	OK
Tank	FEH: 2 years: +0 %: 480 mins: Summer	0.382	0.382	20.4	77.711	0.000	6.4	148.417	75.928	OK
Bioretention 2	FEH: 2 years: +0 %: 120 mins: Summer	0.243	0.201	1.2	1.625	0.000	0.7	1.904	58.027	OK
Bioretention 3	FEH: 2 years: +0 %: 120 mins: Summer	0.201	0.201	1.2	1.390	0.000	0.8	1.803	59.809	OK
Bioretention 4	FEH: 2 years: +0 %: 240 mins: Summer	0.200	0.200	1.1	2.573	0.000	0.7	3.272	58.705	OK

Project: Alston Dairy	Date: 02/07/2025		
	Designed by: JR	Checked by: RG	Approved By: RG
Report Details: Type: Stormwater Controls Summary Storm Phase: Phase	Company Address: Pluviam Environmental		



FEH: 30 years: Increase Rainfall (%): +0: Critical Storm Per Item: Rank By: Max. Outflow

Stormwater Control	Storm Event	Max. US Depth (m)	Max. DS	Max. Inflow (L/s)	Max. Residant	Max. Flooded Volume (m³)	Max. Outflow (L/s)	Total Discharge Volume (m³)	Percentage Available (%)	Status
Dry Swale 1	FEH: 30 years: +0 %: 60 mins: Summer	0.183	0.199	5.6	3.191	0.000	2.2	6.990	0.000	Flood Risk
Dry Swale 2	FEH: 30 years: +0 %: 15 mins: Summer	0.094	0.176	14.3	2.056	0.000	7.4	6.176	0.000	Flood Risk
Bioretention 1	FEH: 30 years: +0 %: 60 mins: Summer	0.321	0.209	5.7	6.667	0.000	1.1	2.547	51.506	OK
Porous Paving	FEH: 30 years: +0 %: 120 mins: Summer	0.141	0.082	2.2	3.363	0.000	0.4	2.197	72.533	OK
Tank	FEH: 30 years: +0 %: 960 mins: Summer	0.661	0.661	21.1	134.691	0.000	6.6	313.407	58.278	OK
Bioretention 2	FEH: 30 years: +0 %: 15 mins: Winter	0.494	0.495	5.1	2.362	0.000	1.0	0.831	39.014	OK
Bioretention 3	FEH: 30 years: +0 %: 15 mins: Winter	0.512	0.512	4.8	2.157	0.000	1.1	0.945	37.654	OK
Bioretention 4	FEH: 30 years: +0 %: 30 mins: Summer	0.472	0.397	4.7	3.772	0.000	1.2	1.883	39.460	OK

Project: Alston Dairy	Date: 02/07/2025		
	Designed by: JR	Checked by: RG	Approved By: RG
Report Details: Type: Stormwater Controls Summary Storm Phase: Phase	Company Address: Pluviam Environmental		



FEH: 30 years: Increase Rainfall (%): +40: Critical Storm Per Item: Rank By: Max. Outflow

Stormwater Control	Storm Event	Max. US Depth (m)	Max. DS	Max. Inflow (L/s)	Max. Residant	Max. Flooded Volume (m³)	Max. Outflow (L/s)	Total Discharge Volume (m³)	Percentage Available (%)	Status
Dry Swale 1	FEH: 30	0.243	0.259	7.8	4.920	0.000	2.5	9.774	0.000	Flood Risk
Dry Swale 2	FEH: 30	0.155	0.237	20.0	3.533	0.000	9.0	8.641	0.000	Flood Risk
Bioretention 1	FEH: 30	0.675	0.211	5.8	9.525	0.000	1.3	7.890	30.719	OK
Porous Paving	FEH: 30	0.197	0.116	3.1	4.749	0.000	0.5	3.151	61.205	OK
Tank	FEH: 30	1.204	1.204	46.7	245.347	0.000	6.6	299.919	24.001	OK
Bioretention 2	FEH: 30	0.836	0.853	4.7	4.535	0.000	1.2	4.904	-17.099	Flood Risk
Bioretention 3	FEH: 30	0.828	0.836	3.5	3.823	0.000	1.3	4.802	-10.532	Flood Risk
Bioretention 4	FEH: 30	0.807	0.660	6.0	5.907	0.000	1.4	5.417	5.190	Flood Risk

Project: Alston Dairy	Date: 02/07/2025		
	Designed by: JR	Checked by: RG	Approved By: RG
Report Details: Type: Stormwater Controls Summary Storm Phase: Phase	Company Address: Pluviam Environmental		



FEH: 100 years: Increase Rainfall (%): +0: Critical Storm Per Item: Rank By: Max. Outflow

Stormwater Control	Storm Event	Max. US Depth (m)	Max. DS	Max. Inflow (L/s)	Max. Residant	Max. Flooded Volume (m³)	Max. Outflow (L/s)	Total Discharge Volume (m³)	Percentage Available (%)	Status
Dry Swale 1	FEH: 100 years: +0 %: 60 mins: Summer	0.225	0.241	7.2	4.368	0.000	2.4	8.940	0.000	Flood Risk
Dry Swale 2	FEH: 100 years: +0 %: 15 mins: Summer	0.134	0.216	17.9	2.970	0.000	8.5	7.743	0.000	Flood Risk
Bioretention 1	FEH: 100 years: +0 %: 60 mins: Winter	0.481	0.214	5.9	8.287	0.000	1.3	4.047	39.723	OK
Porous Paving	FEH: 100 years: +0 %: 60 mins: Summer	0.149	0.103	4.0	4.018	0.000	0.5	1.908	67.179	OK
Tank	FEH: 100 years: +0 %: 1440 mins: Winter	0.656	0.656	12.5	133.655	0.000	6.6	426.515	58.599	OK
Bioretention 2	FEH: 100 years: +0 %: 60 mins: Summer	0.816	0.832	4.3	4.094	0.000	1.2	4.442	-5.730	Flood Risk
Bioretention 3	FEH: 100 years: +0 %: 60 mins: Winter	0.809	0.813	3.2	3.415	0.000	1.3	4.327	1.262	Flood Risk
Bioretention 4	FEH: 100 years: +0 %: 60 mins: Summer	0.807	0.531	5.5	5.353	0.000	1.2	4.938	14.083	Flood Risk

Project: Alston Dairy	Date: 02/07/2025		
	Designed by: JR	Checked by: RG	Approved By: RG
Report Details: Type: Stormwater Controls Summary Storm Phase: Phase	Company Address: Pluviam Environmental		



FEH: 100 years: Increase Rainfall (%): +50: Critical Storm Per Item: Rank By: Max. Outflow

Stormwater Control	Storm Event	Max. US Depth (m)	Max. DS	Max. Inflow (L/s)	Max. Residant	Max. Flooded Volume (m³)	Max. Outflow (L/s)	Total Discharge Volume (m³)	Percentage Available (%)	Status
Dry Swale 1	FEH: 100	0.315	0.331	10.7	7.461	0.000	2.9	13.269	0.000	Flood Risk
Dry Swale 2	FEH: 100	0.222	0.304	18.5	5.569	0.000	10.5	16.025	0.000	Flood Risk
Bioretention 1	FEH: 100	0.806	0.352	5.0	12.610	0.000	1.5	16.476	8.275	Flood Risk
Porous Paving	FEH: 100	0.224	0.158	6.0	6.136	0.000	0.6	2.824	49.877	OK
Tank	FEH: 100	1.506	1.506	28.4	306.722	0.000	6.6	642.374	4.989	OK
Bioretention 2	FEH: 100	0.914	0.931	5.2	6.346	0.000	1.3	6.063	-63.864	Flood Risk
Bioretention 3	FEH: 100	0.902	0.910	4.3	5.193	0.000	1.3	8.334	-50.111	Flood Risk
Bioretention 4	FEH: 100	0.854	0.866	4.2	7.892	0.000	1.4	10.874	-26.673	Flood Risk

Project: Alston Dairy	Date: 02/07/2025		
	Designed by: JR	Checked by: RG	Approved By: RG
Report Details: Type: Phase Management Storm Phase: Phase	Company Address: Pluviam Environmental		



Phase
FEH: 2 years: Increase Rainfall (%): +0: 480 mins: Summer

Tables

Name	Max. Inflow (L/s)	Total Inflow Volume (m³)	Max. Outflow (L/s)	Total Outflow Volume (m³)
SW14			6.4	148.403
TOTAL	22.0	161.876	6.4	148.403

Graphs

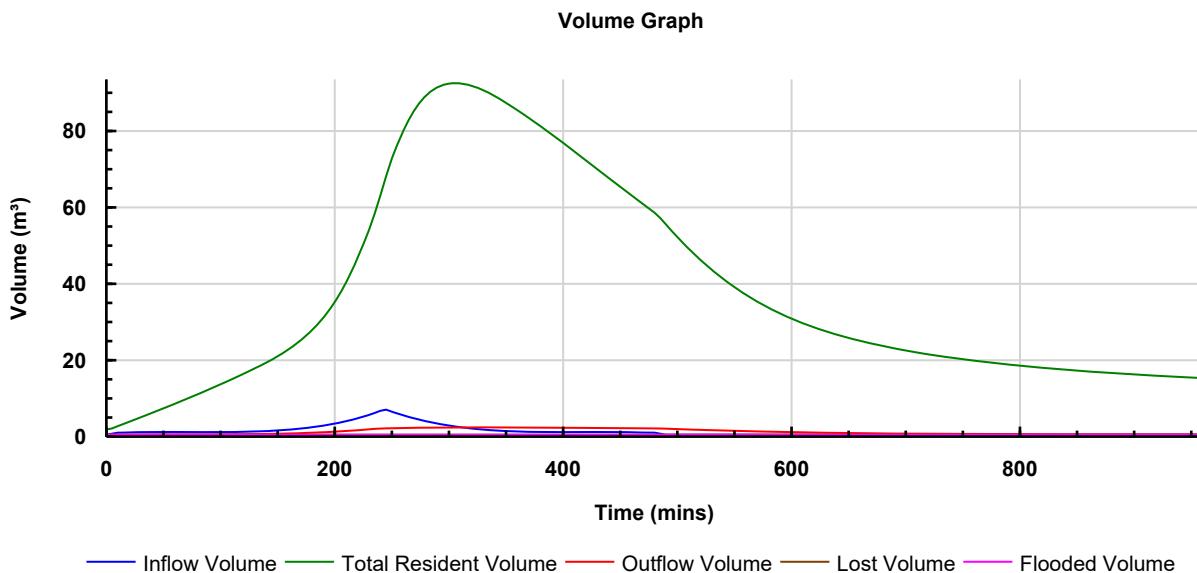
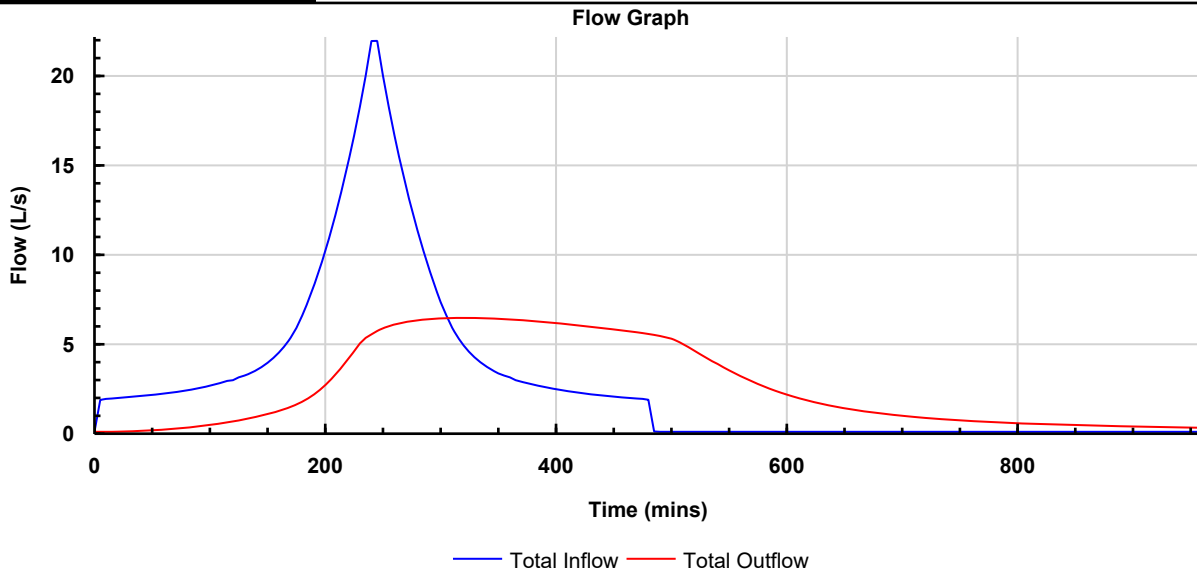

Project: Alston Dairy	Date: 02/07/2025		
	Designed by: JR	Checked by: RG	Approved By: RG
Report Details: Type: Phase Management Storm Phase: Phase	Company Address: Pluviam Environmental		



Phase
FEH: 30 years: Increase Rainfall (%): +0: 480 mins: Summer

Tables

Name	Max. Inflow (L/s)	Total Inflow Volume (m³)	Max. Outflow (L/s)	Total Outflow Volume (m³)
SW14			6.6	253.485
TOTAL	37.1	273.719	6.6	253.485

Graphs

Flow Graph

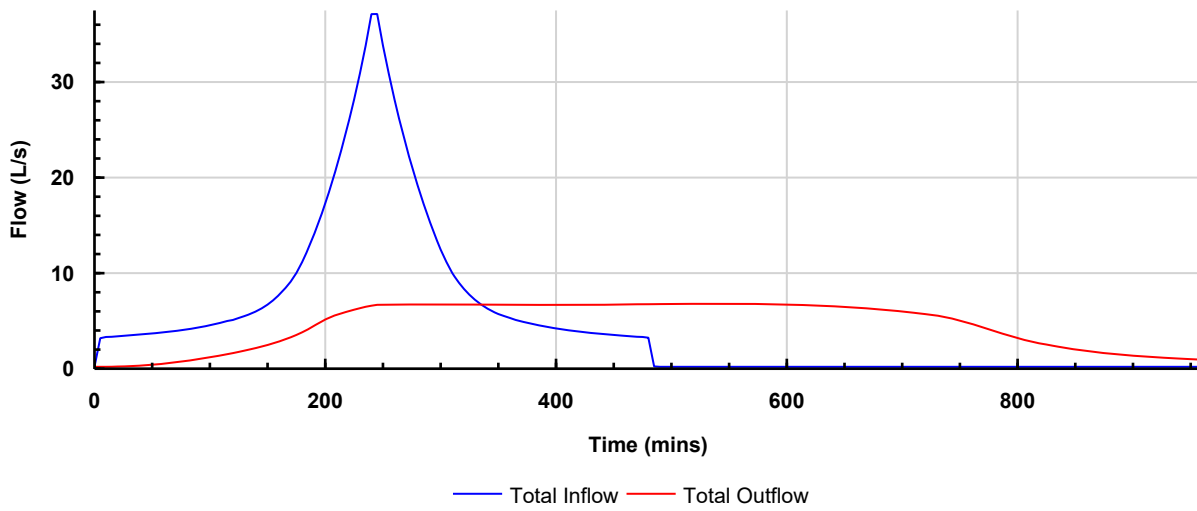

Volume Graph

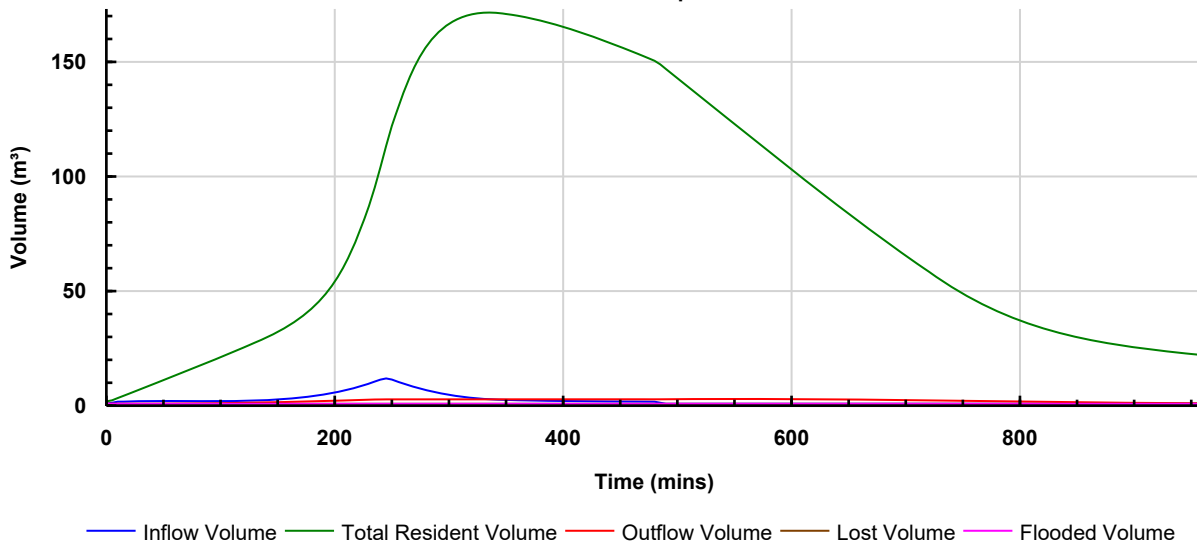

Project: Alston Dairy	Date: 02/07/2025		
	Designed by: JR	Checked by: RG	Approved By: RG
Report Details: Type: Phase Management Storm Phase: Phase	Company Address: Pluviam Environmental		



Phase
FEH: 30 years: Increase Rainfall (%): +40: 480 mins: Summer

Tables

Name	Max. Inflow (L/s)	Total Inflow Volume (m³)	Max. Outflow (L/s)	Total Outflow Volume (m³)
SW14			6.6	299.827
TOTAL	52.0	383.203	6.6	299.827

Graphs

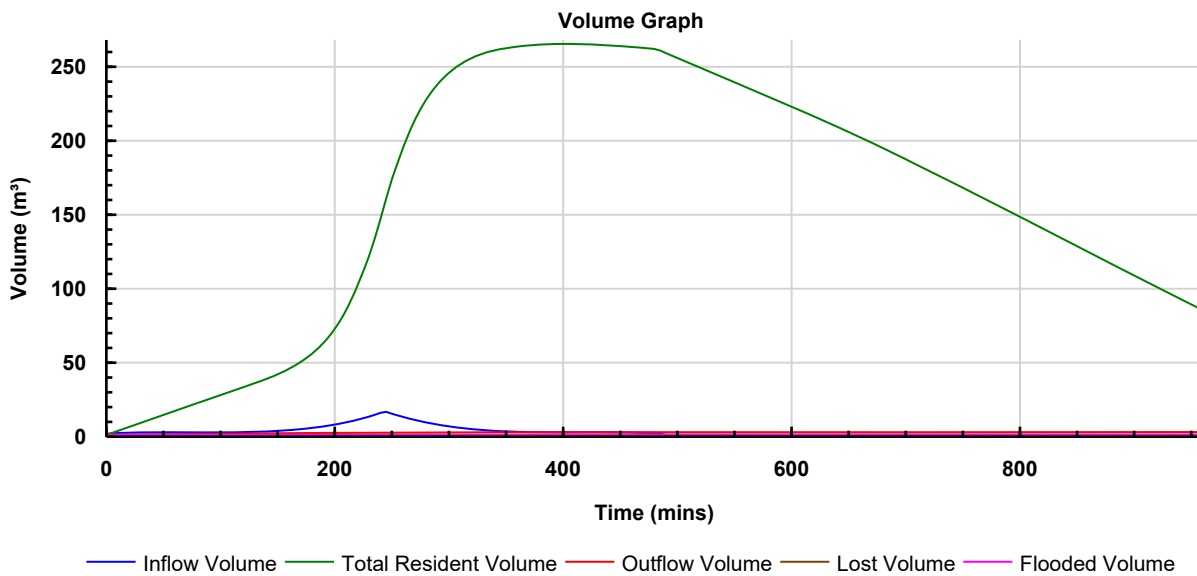
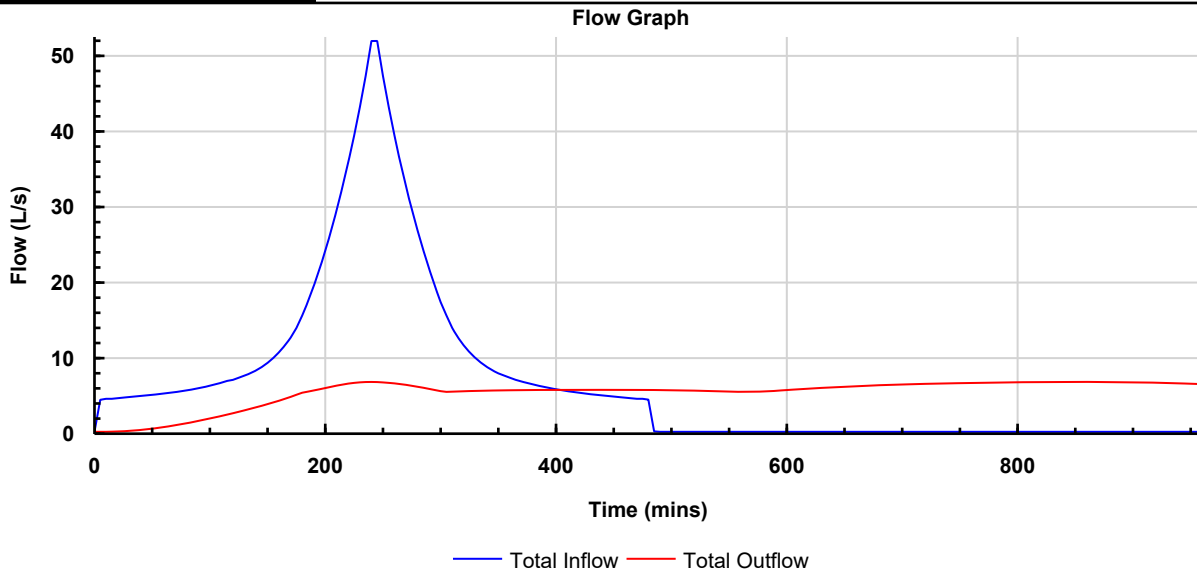

Project: Alston Dairy	Date: 02/07/2025		
	Designed by: JR	Checked by: RG	Approved By: RG
Report Details: Type: Phase Management Storm Phase: Phase	Company Address: Pluviam Environmental		



Phase
FEH: 100 years: Increase Rainfall (%): +0: 30 mins: Winter

Tables

Name	Max. Inflow (L/s)	Total Inflow Volume (m³)	Max. Outflow (L/s)	Total Outflow Volume (m³)
SW14			6.6	17.622
TOTAL	161.1	148.635	6.6	17.622

Graphs

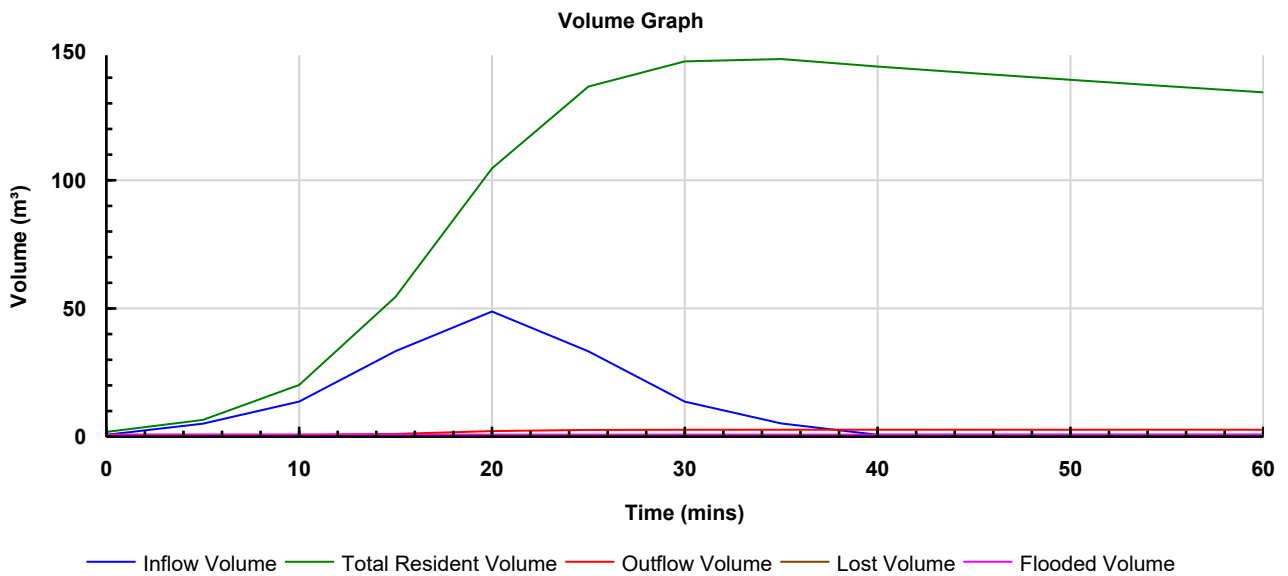
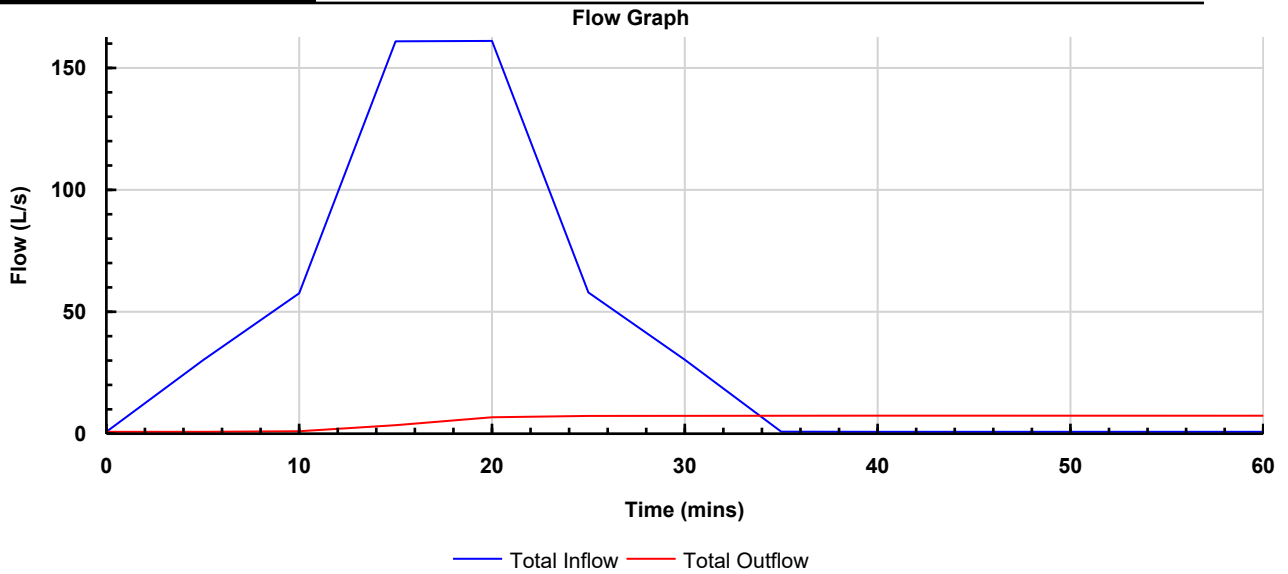

Project: Alston Dairy	Date: 02/07/2025		
	Designed by: JR	Checked by: RG	Approved By: RG
Report Details: Type: Phase Management Storm Phase: Phase	Company Address: Pluviam Environmental		



Phase
FEH: 100 years: Increase Rainfall (%): +50: 1440 mins: Summer

Tables

Name	Max. Inflow (L/s)	Total Inflow Volume (m³)	Max. Outflow (L/s)	Total Outflow Volume (m³)
SW14			6.6	642.365
TOTAL	29.7	654.087	6.6	642.365

Graphs

Flow Graph

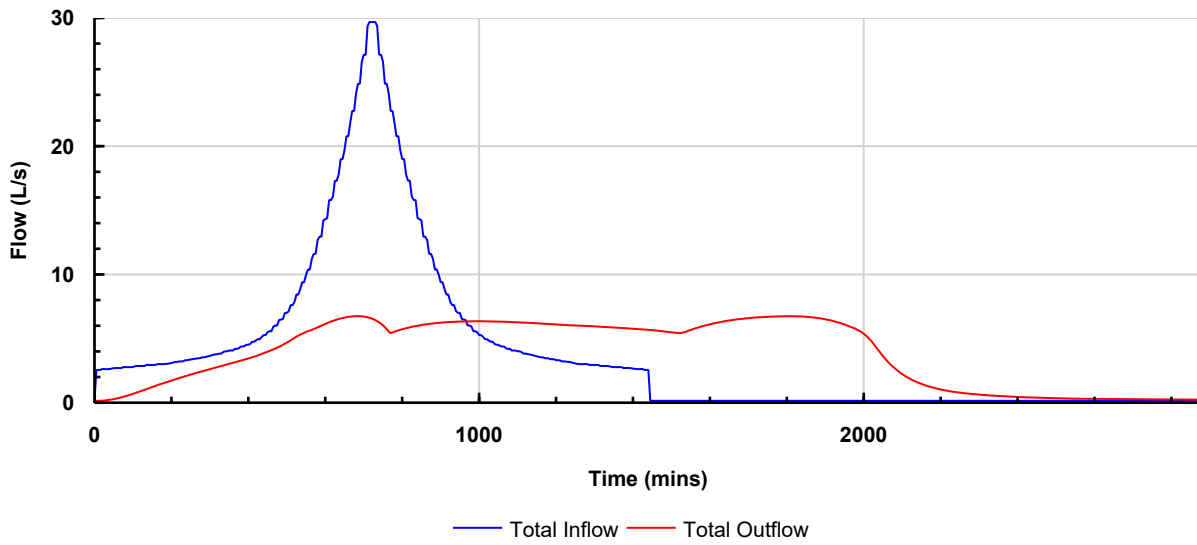

Volume Graph

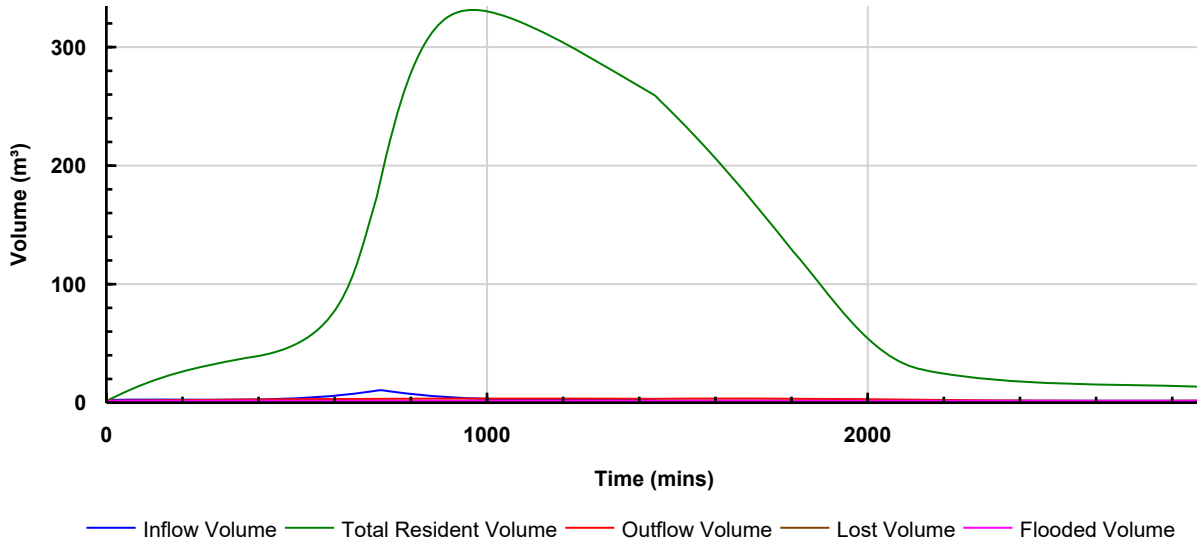

Appendix G

Proposed Outline Drainage Layout and Details

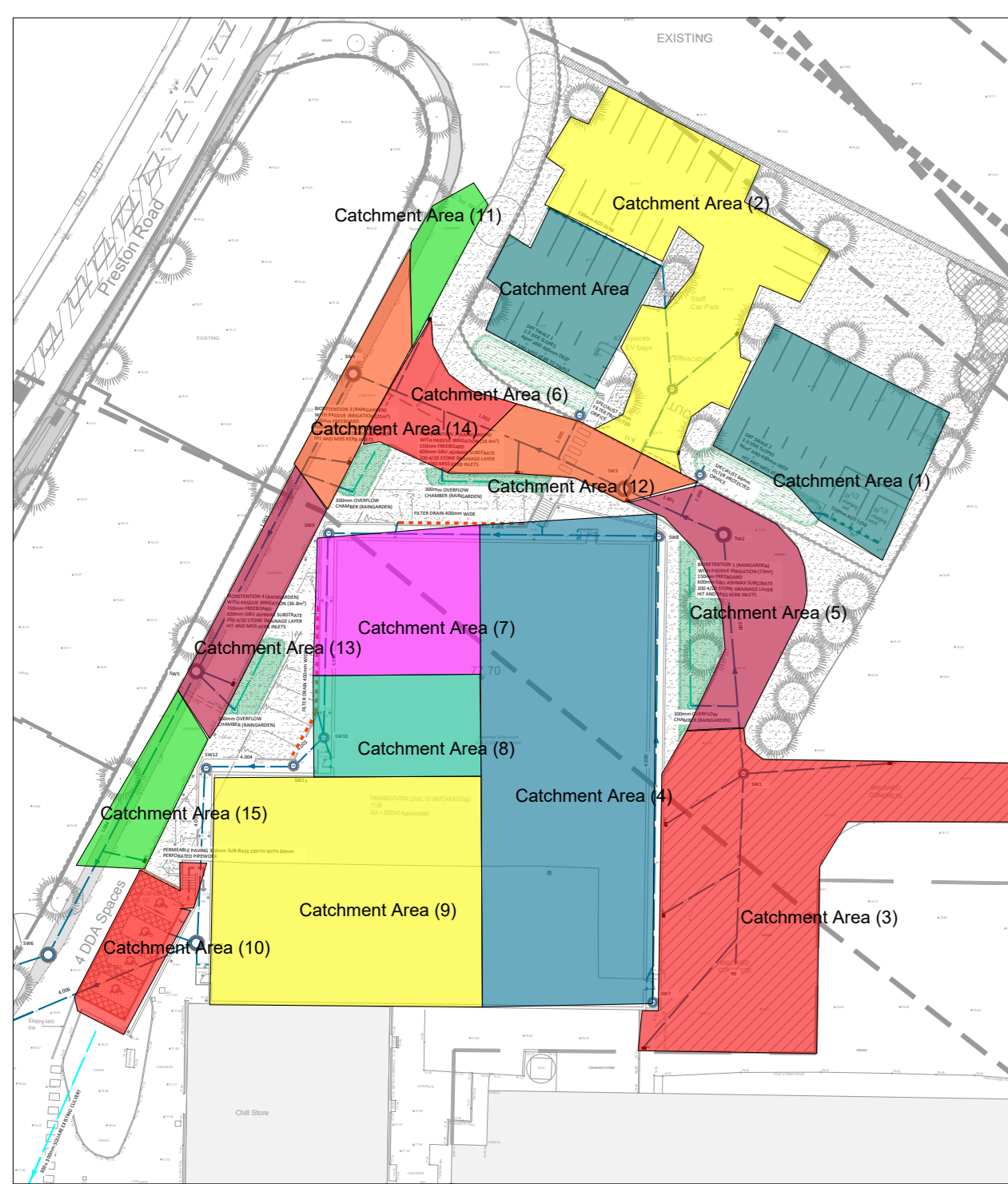

CATCHMENT DIAGRAM
 (REFER TO INFORAINAGE AND DRAINAGE STRATEGY REPORT WITH REFERENCE
 CATCHMENT NAMES FOR AREAS IN HA)
 TOTAL CATCHMENT: 0.565 ha

- SERVICES COORDINATION TO BE COMPLETED
- PROPOSED LEVELS TO BE CONFIRMED
- EXISTING COVERT TO BE PROTECTED DURING WORKS

limit of 76m Building Proximity
 Distance each side of gas main



1. DO NOT SCALE THIS DRAWING. WORK TO FIGURED DIMENSIONS ONLY. ALL DIMENSIONS ARE IN MILLIMETERS (MM) UNLESS NOTED OTHERWISE.
2. This drawing is to be read in conjunction with all relevant Architect's, Engineer's and Specialist's drawings and their respective specification.
3. All work to comply with relevant British Standards, Codes of practice and the Building Regulations.
4. Any discrepancies between all working drawings, specifications and schedules of all disciplines to be immediately notified to main contractor for clarification (corrected prior to construction of relevant structure).
5. All cover levels are indicative only and shall match Architects proposed levels. Invert levels to be confirmed on site prior to work commencing.
6. All areas of excavation are to be scanned and marked for existing services prior to any excavation.
7. Branch connections to PPI's have been assumed 50mm higher than the main channel.
8. All connections from RWP to be 150mm unless noted otherwise.
9. For the location of all RWP's and SWP's refer to Architects drawings.
10. Stormwater attenuation system shall be Polypropylene pre-formed modular geocellular units with minimum 84% volumetric void ratio and minimum 5% effective perforated surface area. Units shall be installed using locking ties to maintain rigidity and minimise deflection. Geocellular units to be fully encapsulated with Heavy duty geotextile protection fleece and impermeable membrane.
11. Heavy duty geotextile fleece to be non-woven needle-punched polypropylene as per Specification. Geotextile to be laid with minimum 300mm overlaps and to be applied to all external surfaces of Polypropylene Permeable drainage units. To be installed in accordance with the manufacturer's recommendations.
12. Waterproof geomembrane to be single layer cold applied robust welded flexible membrane as per Specification suitable for waterproofing to structure and for water containment. Membrane to be nominal 1mm thick laid with minimum 150mm laps and welded seams. To be installed in accordance with the manufacturer's recommendations under and approved CDA protocol that includes testing of the welds.
13. Linear drainage channel to be ACO S or MO range with sump assemblies.
14. Oil bypass separators to be Kingspan Klargester as noted on drawing.
15. All dimensions are in millimeters unless noted otherwise.
16. Pre-cast concrete products shall comply with the relevant provisions of BS 5911 and be '100 Mark'.
17. All pipes and pipe fittings shall be HDPE twinwall and have current British Board of Agreement Certification.
18. Manhole covers and frames, grids and frames shall comply with the relevant provisions of BS EN 124.
19. Do not scale from this drawing. If in doubt ask.
20. This drawing to be read in conjunction with all relevant P.E.L. Architects & Engineers drawings.
21. Should there be any conflict between the details indicated on this drawing and those on other drawings the Engineer should be informed PRIOR to construction on site.
22. At all times the works are to be executed in accordance with the requirements of the Health And Safety at Work Act 1974 and CDM Regulations 2015.
23. Until technical approval has been obtained from the relevant Authority, it should be understood that all drawings are PRELIMINARY and NOT FOR CONSTRUCTION.

LEGEND

- SURFACE WATER DRAINAGE PIPEWORK
- EXISTING CULVERT
- FILTER DRAIN
- LINEAR DRAINAGE CHANNEL
- 750mm DIA CATCHPIT INSPECTION CHAMBER (SW)
- 1200 dia SW MANHOLE
- PERMEABLE PAVING
- POLYSTYRENE ATTENUATION TANK 1200mm DEEP
- BIORETENTION (RAINGARDEN)
- DRY SWALE

53	P01	04.07.25	First Issue	JR	JR	RG	JR
STATUS REV DATE REVISION HISTORY				DSE DRW CHK APP			
ALL REVISIONS							

CLIENT	EDEN PLANNING
--------	---------------

KEY PLAN	
----------	--



DRAWING TITLE
**SURFACE WATER DRAINAGE LAYOUT
 ALSTON DAIRY EXTENSION**

Designed by	JR	Signature		Date	01/07/2025
Drawn by	JR	Signature		Date	01/07/2025
Checked	RG	Signature		Date	01/07/2025
Approved	JR	Signature		Date	01/07/2025

PER REF	SCALE	@ AD	BIM FILE NAME - REVISION				
PNO259	1:200		PNO259-PEL-XX-DR-Y-00001-P01				
Stage 4			Approval				
PROJECT	ISSUE	VOLUME	LEVEL	TYPE	ROLE	NUMBER	REV
PNO259	PEL	XX	XX	DR	Y	00001	P01

TYPICAL DETAILS FOR BIORETENTION (RAIN GARDEN)

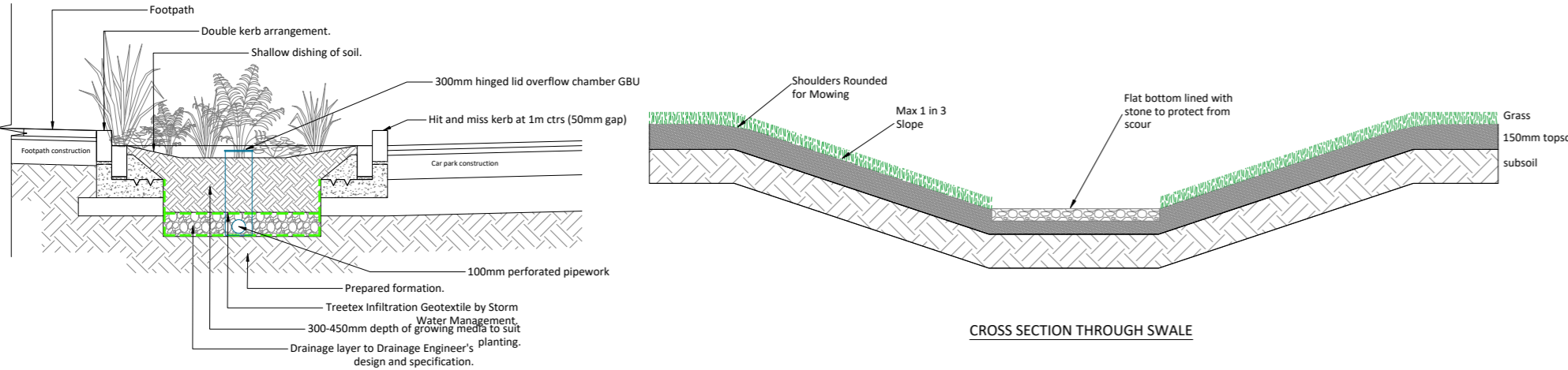

CROSS SECTION THROUGH SWALE

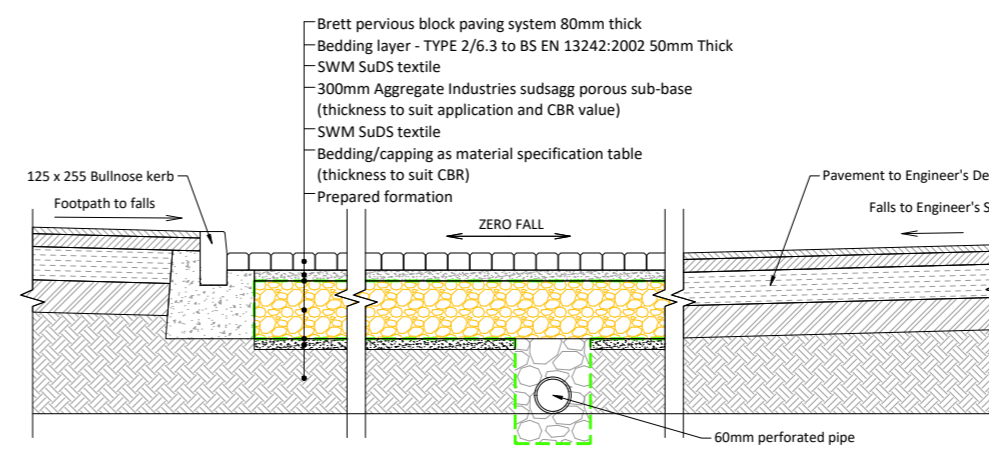

TYPICAL SECTION THROUGH PAVEMENT WITH OPEN GRADED SUB-BASE AND COLLECTOR DRAIN

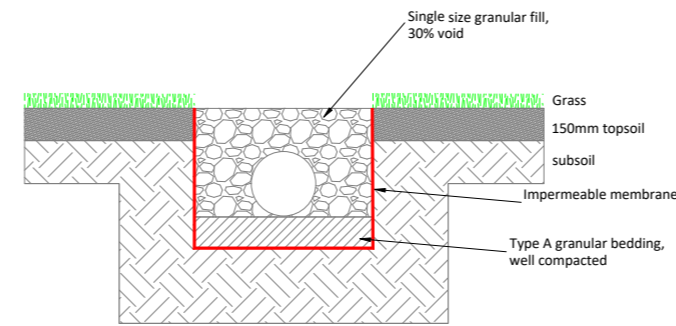

CROSS SECTION THROUGH FILTER DRAIN (1:10)

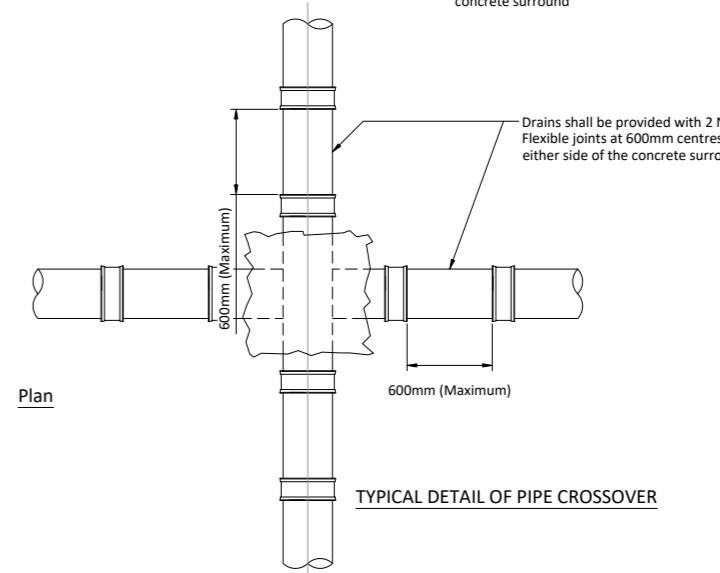
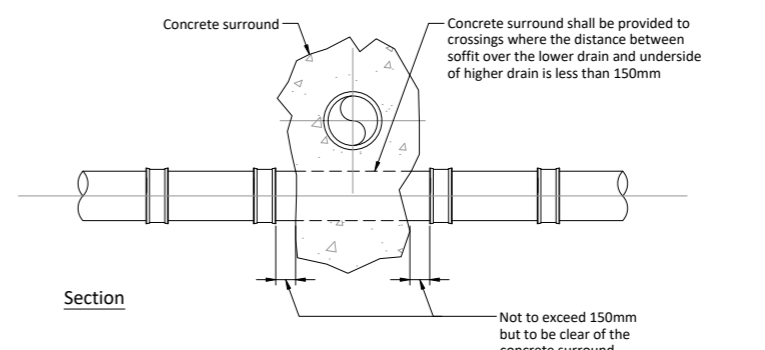

TYPICAL DETAIL OF PIPE CROSSOVER

Table of aggregate sizes for pipe bedding
For rigid pipe materials only

Pipe diameter	Alternative aggregate sizes		Aggregate material
	Single size	Graded	
100Ø	10mm	Not suitable	Natural aggregate
150Ø	10mm or 14mm	14mm - 5	To BS 882
225Ø - 450Ø	10mm or 14mm or 20mm	14mm - 5 or 20mm - 5	Either crushed or as dug
500Ø and above	14mm or 20mm	14mm - 5 or 20mm - 5 or 40 - 5	Must be crushed stone

Table 1
Capping layer & sub base thickness

CBR (%)	Sub-base thickness
< 2%	610mm
2%	420mm
2.5%	370mm
3%	310mm
4%	300mm (Minimum)

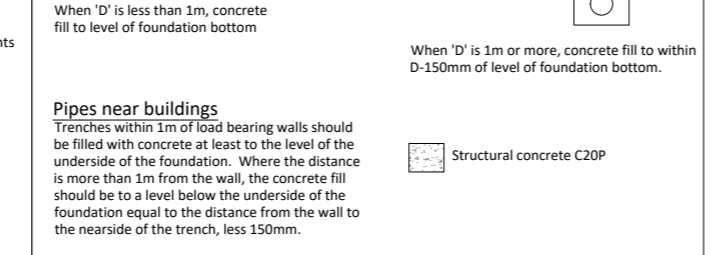
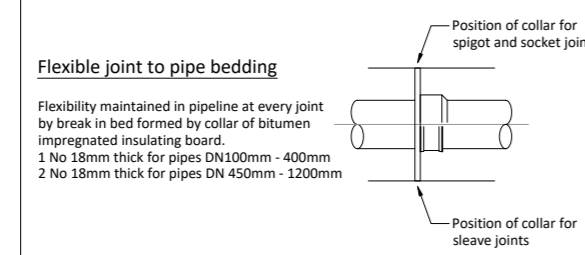

Pipe bedding details
Class A bedding shall be used on all pipelines with less than 1.2m depth to soffit in adoptable highways and other vehicular areas, and all other areas where depth to soffit is less than 0.9m

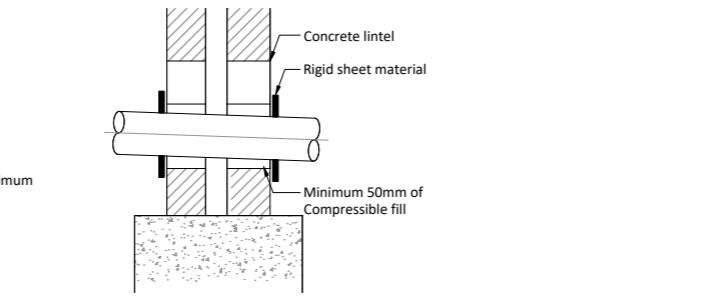
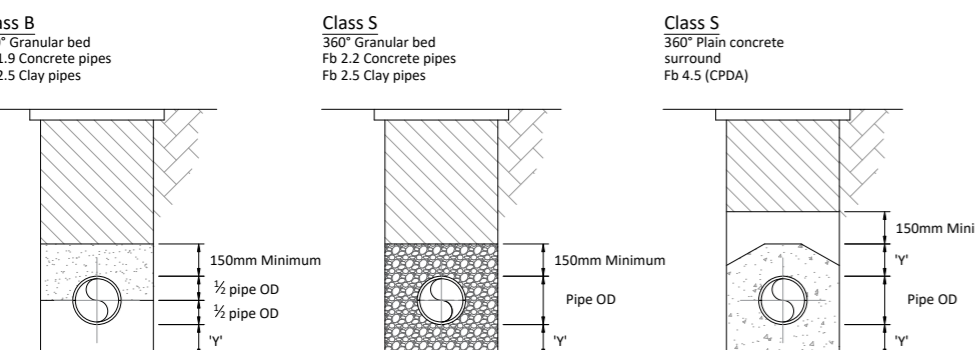

DRAIN PENETRATING THROUGH WALLS

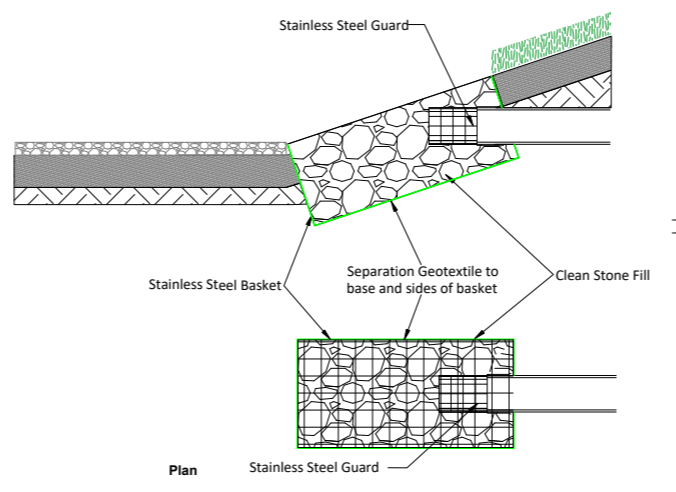

BASKETED DIFFUSER OUTLET DETAIL - SWALE

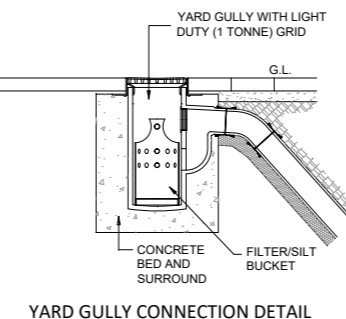

YARD GULLY CONNECTION DETAIL

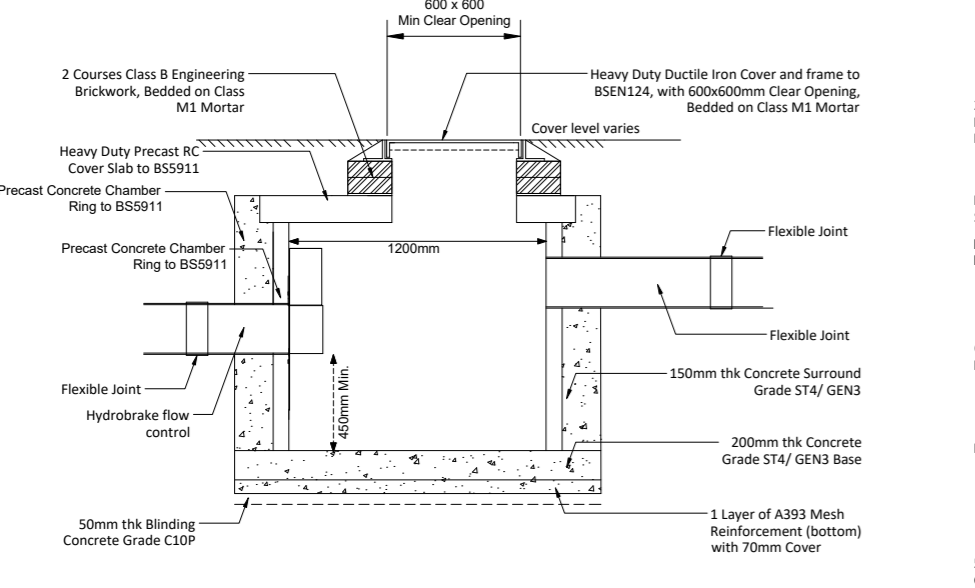

TYPICAL 1200mm FLOW CONTROL CATCHPIT

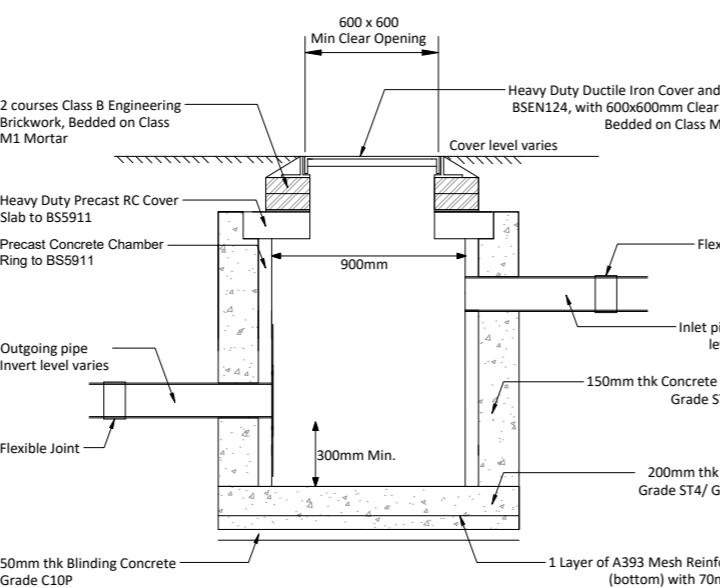

900Ø CATCHPIT INSPECTION CHAMBER (750Ø Similar) SUMP REQUIRED ON SURFACE WATER NETWORK ONLY

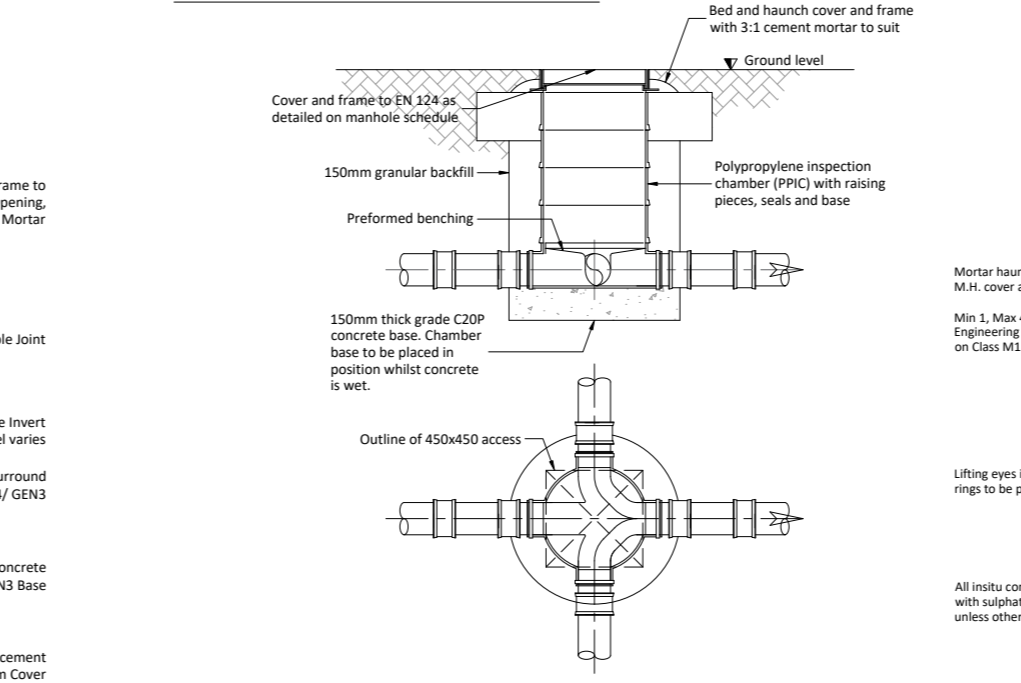

DETAIL OF 500mm/600mm POLYPROPYLENE INSPECTION CHAMBER MAXIMUM DEPTH TO SOFFIT 1.20m MANHOLE TYPE A

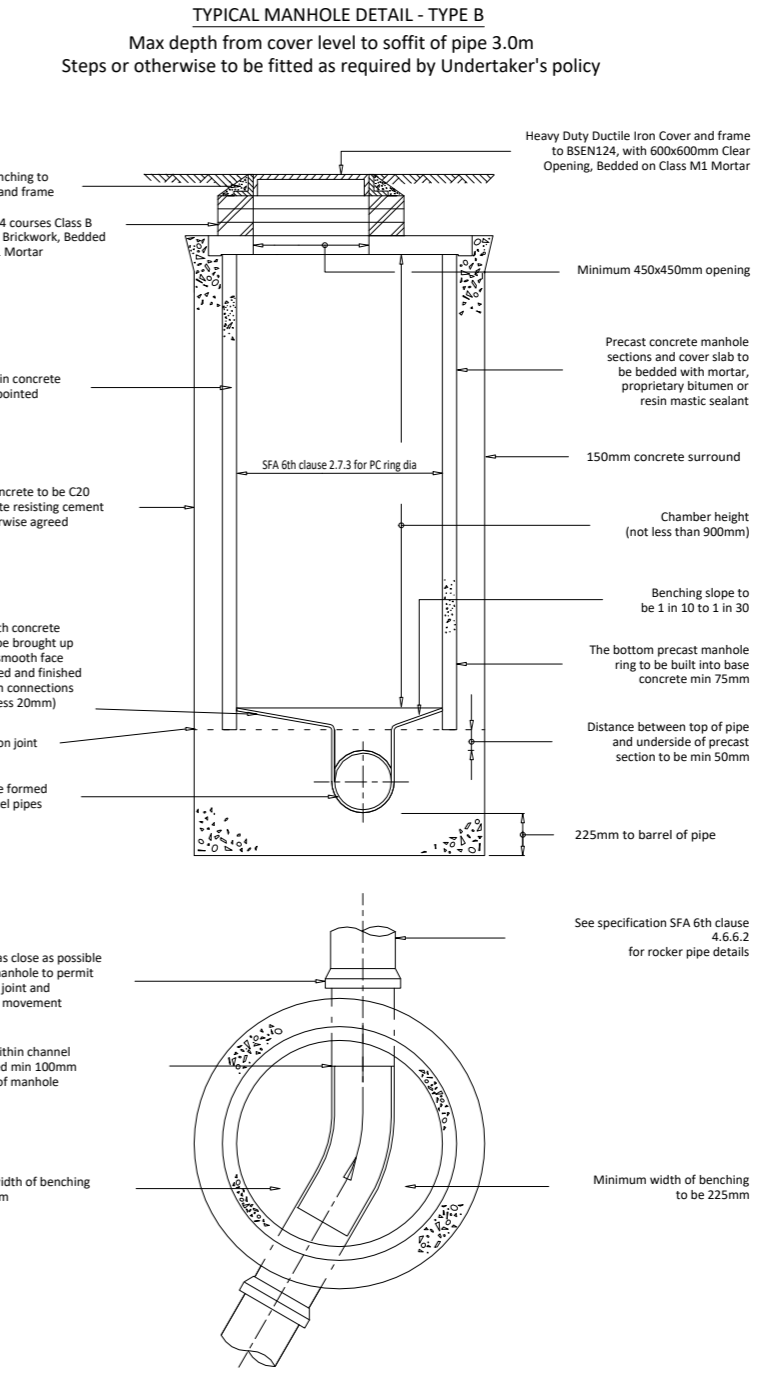

TYPICAL MANHOLE DETAIL - TYPE B
Max depth from cover level to soffit of pipe 3.0m
Steps or otherwise to be fitted as required by Undertaker's policy

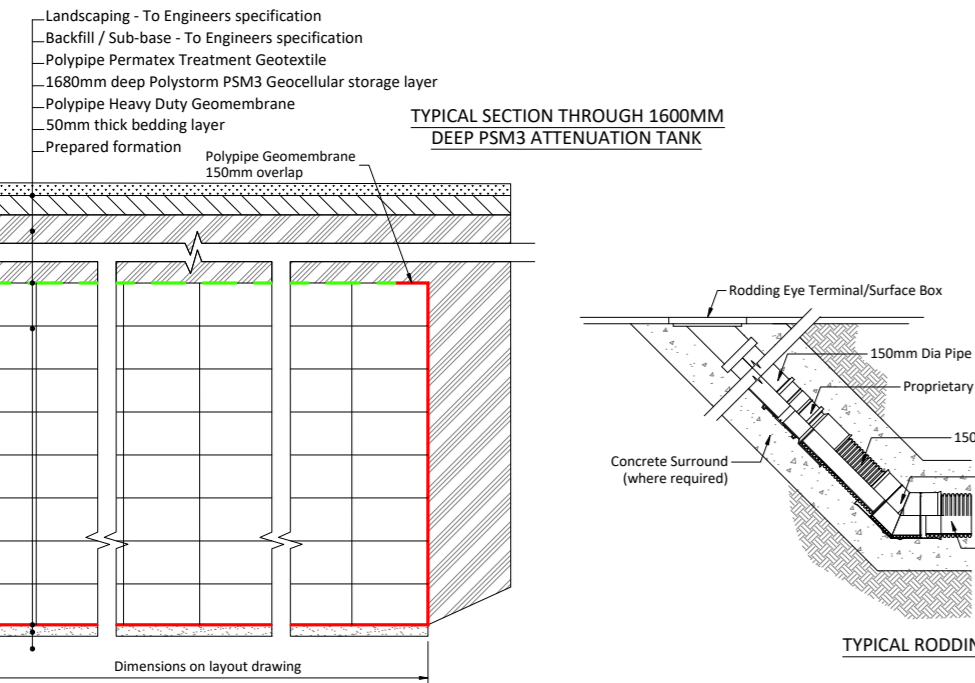

TYPICAL SECTION THROUGH 1600MM DEEP PSM3 ATTENUATION TANK

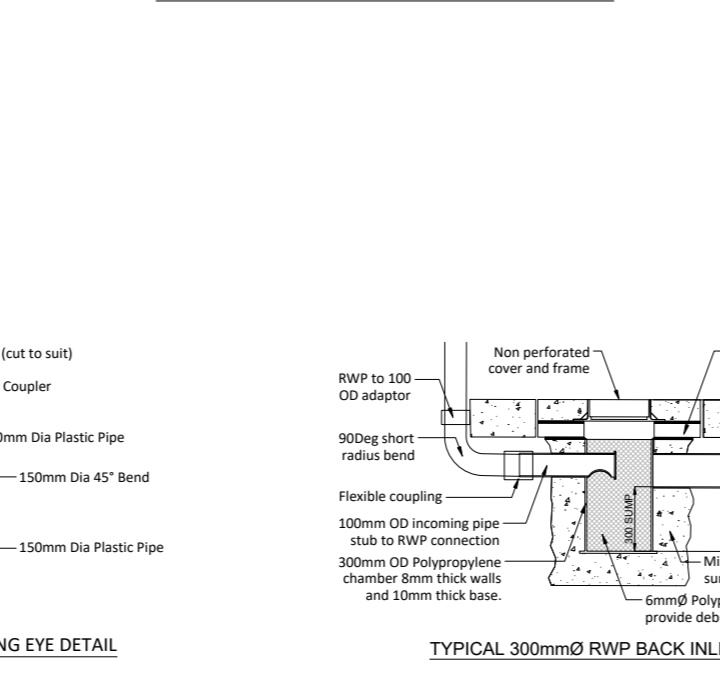

TYPICAL 300mmØ RWP BACK INLET GULLY

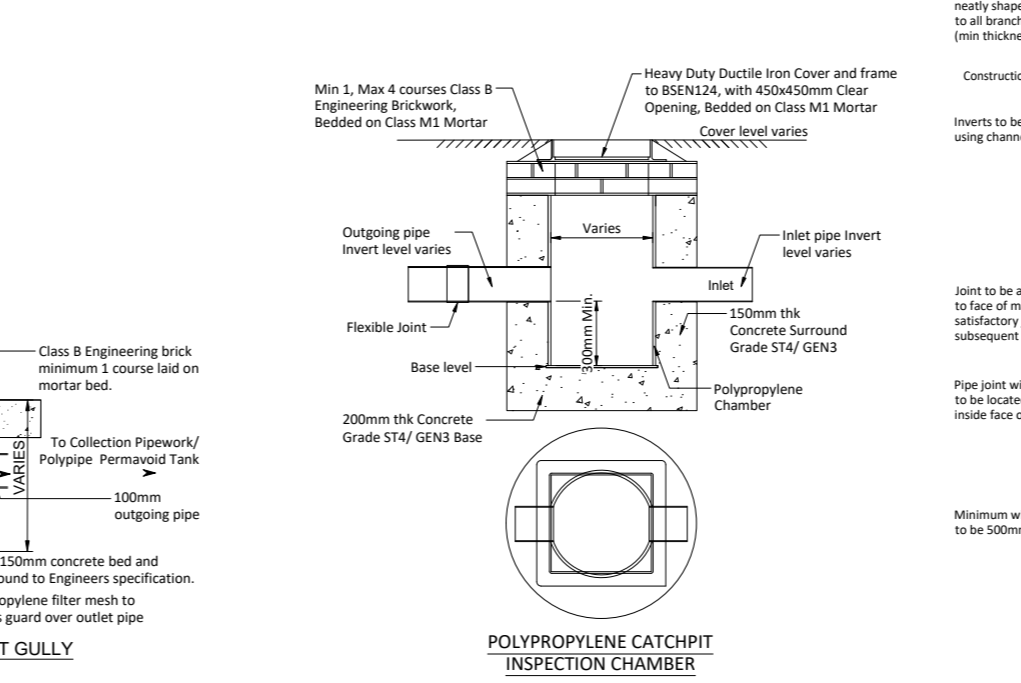

POLYPROPYLENE CATCHPIT INSPECTION CHAMBER

- Notes:**
- DO NOT SCALE THIS DRAWING. WORK TO FIGURED DIMENSIONS ONLY. ALL DIMENSIONS ARE IN MILLIMETERS (mm) UNLESS NOTED OTHERWISE.
 - This drawing is to be read in conjunction with all relevant Architect's, Engineer's and Specialist's drawings and their respective specification.
 - All work to comply with relevant British Standards, Codes of practice and the Building Regulations.
 - Any discrepancies between all working drawings, specifications and schedules of all disciplines to be immediately notified to main contractor for clarification/correction prior to construction of relevant structure.
 - All cover levels are indicative only and shall match Architects proposed levels. Invert levels to be confirmed on site prior to work commencing.
 - All areas of excavation are to be scanned and marked for existing services prior to any excavation.
 - Branch connections to PPIC's have been assumed 50mm higher than the main channel.
 - All connections from RWP to be 160mmØ unless noted otherwise.
 - For the location of all RWP's and SVP's refer to Architects drawings.
 - Stormwater attenuation system shall be Polypropylene pre-formed modular geocellular units with minimum 94% volumetric void ratio and minimum 52% effective perforated surface area. Units shall be installed using locking ties to maintain rigidity and minimise deflection. Geocellular units to be fully encapsulated with Heavy duty geotextile protection fleece and impermeable membrane.
 - Heavy duty geotextile fleece to be non-woven needle-punched polypropylene as per Specification. Geotextile to be laid with minimum 300mm overlaps and to be applied to all external surfaces of Polypropylene-Permavoid drainage units. To be installed in accordance with the manufacturer's recommendations.
 - Waterproof geomembrane to be single layer cold applied robust welded flexible membrane as per Specification suitable for waterproofing to structure and for water containment. Membrane to be nominal 1mm thick laid with minimum 150mm laps and welded seams. To be installed in accordance with the manufacturer's recommendations under and approved CQA protocol that includes testing of the welds.
 - Linear drainage channel to be ACO S or MD range with sump assemblies.
 - Oil bypass separators to be Kingspan Klargester as noted on drawing.
 - All dimensions are in millimeters unless noted otherwise.
 - Pre-cast concrete products shall comply with the relevant provisions of BS 5911 and be 'Kite Marked'.
 - All pipes and pipe fittings shall be HDPE twinwall and have current British Board of Agreement Certification.
 - Manhole covers and frames, grids and frames shall comply with the relevant provisions of BS EN 124.
 - Do not scale from this drawing. If in doubt ask.
 - This drawing to be read in conjunction with all relevant PEL, Architects & Engineers drawings.
 - Should there be any conflict between the details indicated on this drawing and those on other drawings the Engineer should be informed PRIOR to construction on site.
 - At all times the works are to be executed in accordance with the requirements of the Health and Safety at Work Act 1974 and CDM Regulations 2015.
 - Until technical approval has been obtained from the relevant Authority, It should be understood that all drawings are **PRELIMINARY** and **NOT FOR CONSTRUCTION**.

NO	REV	DATE	REVISION HISTORY	DESIGNED	CHECKED	APPROVED
53	PO1	04.07.25	First Issue	JR	JR	JR

CLIENT
EDEN PLANNING

KEY PLAN

ORIGINATOR
PLUVIAM ENVIRONMENTAL

DRAWING TITLE
SURFACE WATER DRAINAGE DETAILS
ALSTON DAIRY EXTENSION

Name	Signature	Date
Designed by	JR	01/07/2025
Drawn by	JR	01/07/2025
Checked	RG	01/07/2025
Approved	JR	01/07/2025

PEL REF	SCALE	@ A1	BIM FILE NAME - REVISION
PN0259	1:25		PN0259-PEL-XX-XX-DR-Y-0002-PO1
Stage 4			Approval

PROJECT	ISSUER	VOLUME	LEVEL	TYPE	ROLE	NUMBER	REV
PN0259		XX	XX	DR	Y	00002	PO1