

Vehicle Used in the Swept Path Analysis

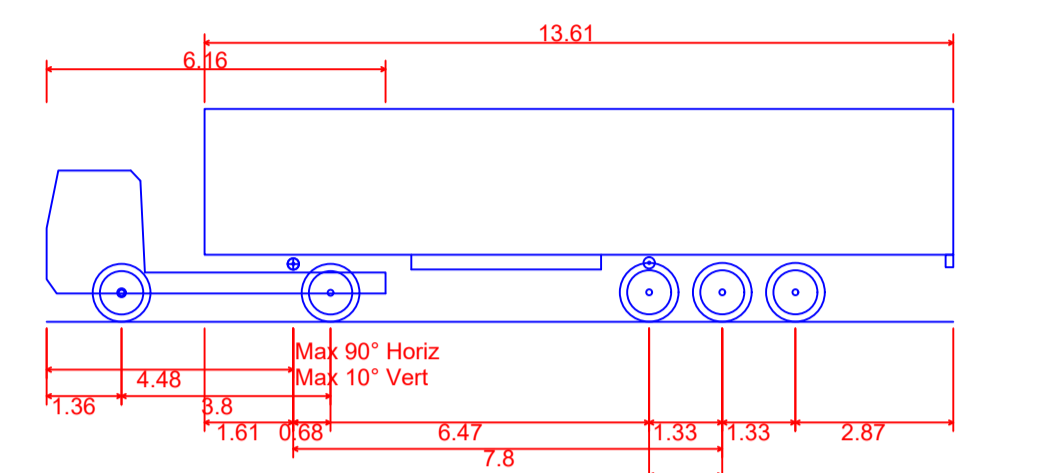

FTA Design Articulated Vehicle (2016)	
Overall Length	16.480m
Overall Width	2.550m
Overall Body Height	3.870m
Min Body Ground Clearance	0.515m
Max Track Width	2.470m
Lock to lock time	3.00s
Kerb to Kerb Turning Radius	6.600m

- Notes**
1. Give Way to oncoming vehicles proposed on the approach into the yard.
 2. Give way markings proposed on the approach into the yard.

Revisions



Client
Mr Forshaw



Scheme
Bolton Fold Farm

Title
Forward Visibility from The Yard

Drawn	Checked	Date
N.Peet	M.Peet	28.11.2024

Project	Drawing No	Scale
590-24	590-24-1	1:200 @ A1

