

Asbuilt Drawings - as this is a drawing of an existing building there will be variations on site to wall thicknesses and angles that are not depicted in this drawing. Unless stated inaccessible areas such as roofs have been visually observed unless otherwise stated this is not a topographic survey and ground levels and features have been estimated. This drawing is the property of Plans and Planning and should not be reproduced without written permission.

| Revision Number | Revision Date | Revision Description |
|-----------------|---------------|----------------------|
| | | |

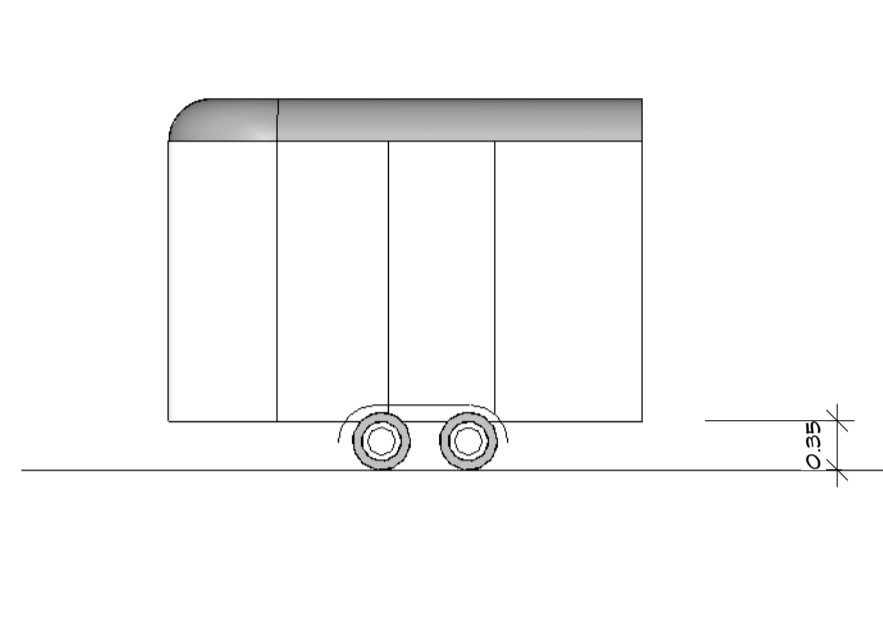

1 Cabin East Elevation
1:50

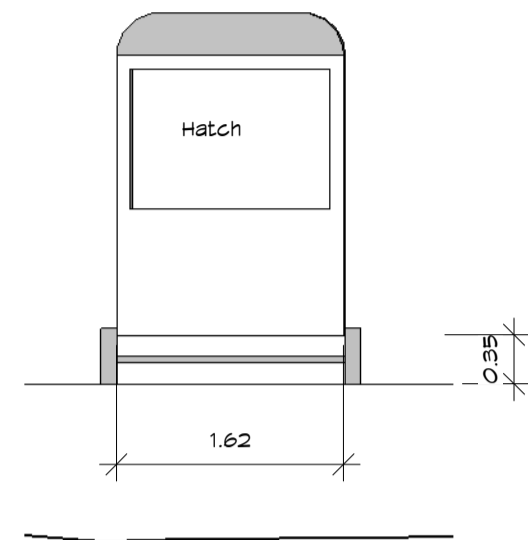

2 Cabin North
1:50

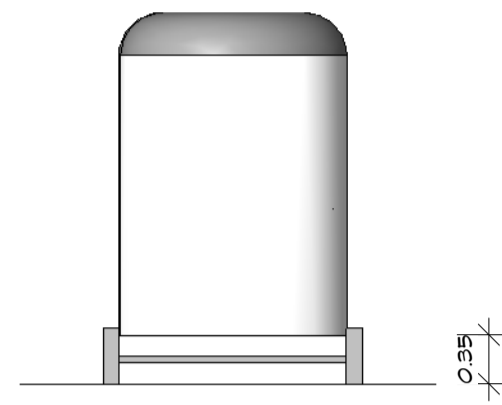

3 Cabin South
1:50

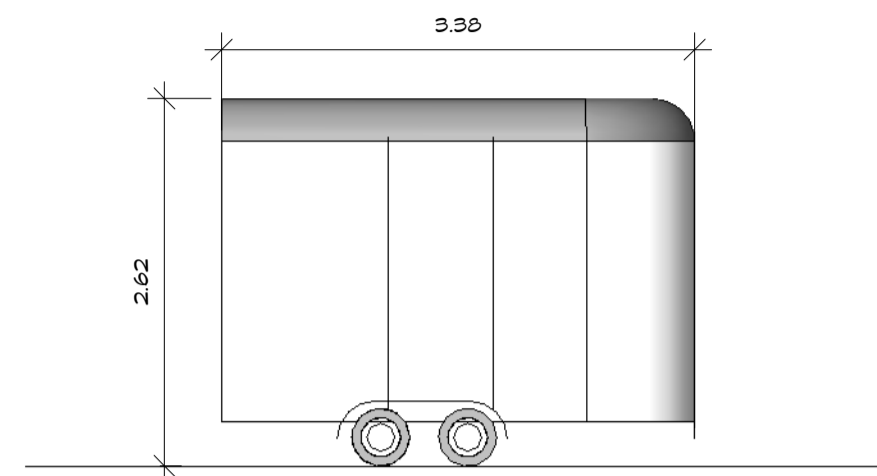

4 Cabin West Elevation1
1:50



Image A - Tea Cabin



Image B - Tea Cabin

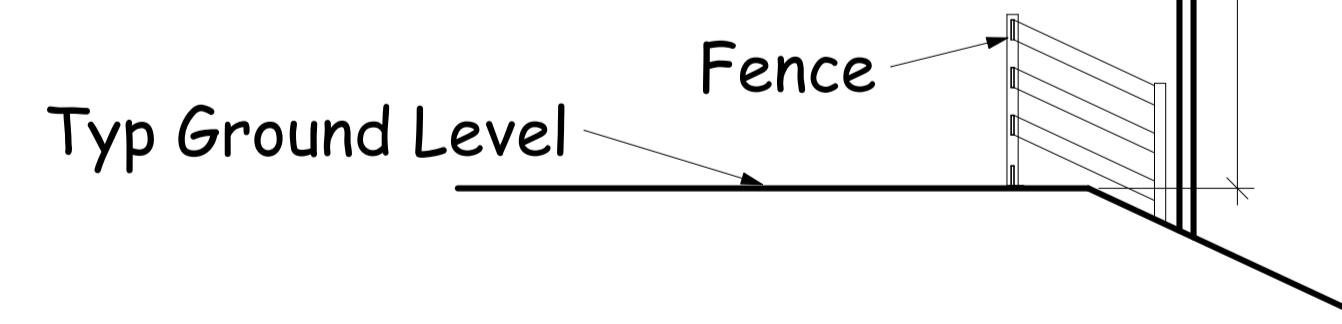
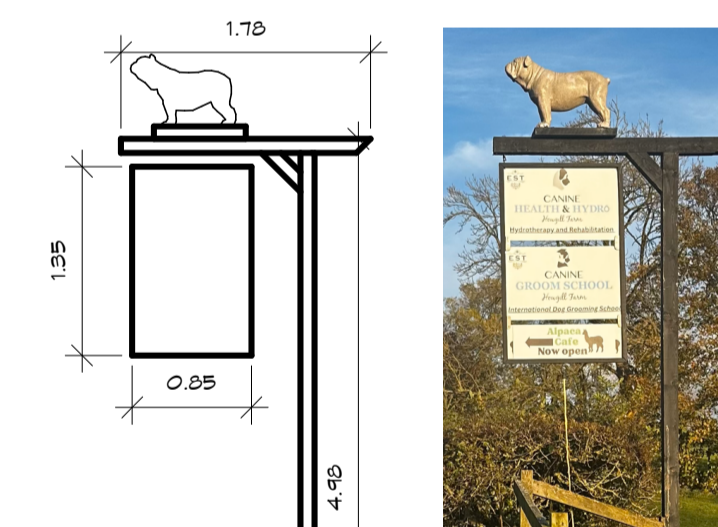
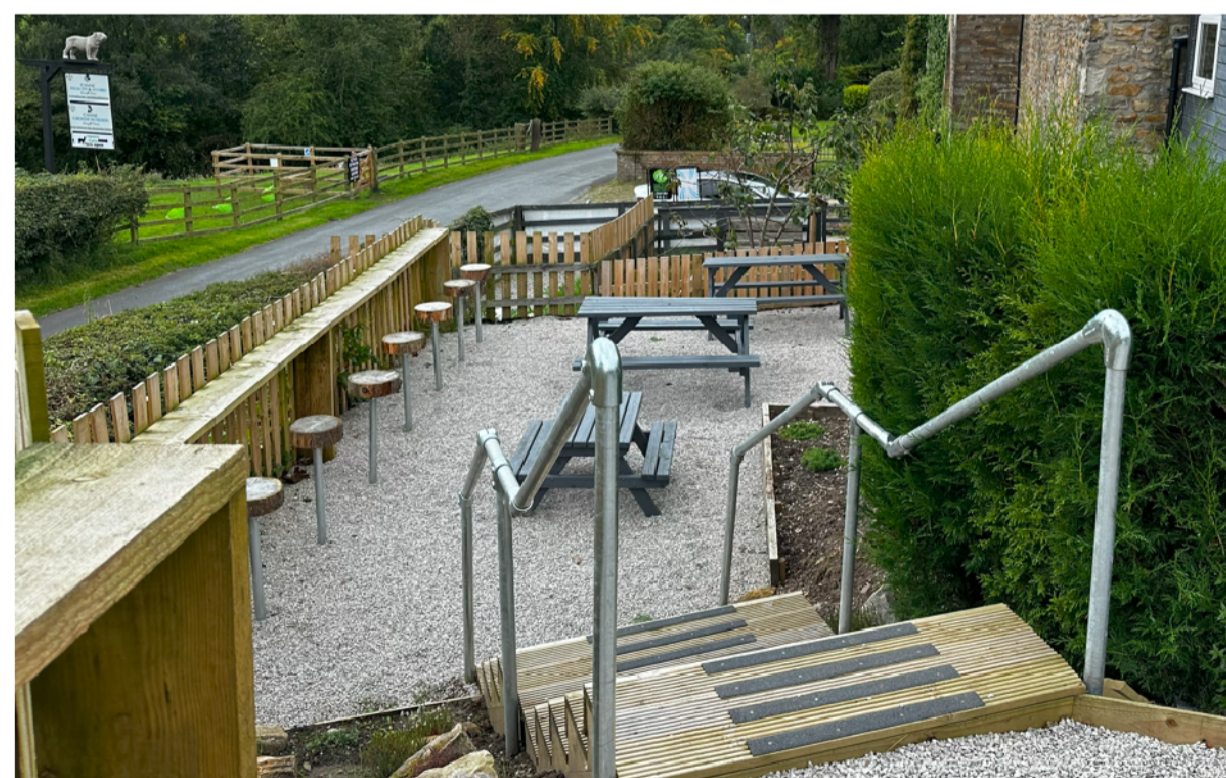

5 Sign
1:50

These are Planning drawings and should not be used for construction. All structural elements are illustrative and dimensions are estimates - no calculations have been completed or specification for building regulations.

| Date | Revision |
|------|----------|
| | |
| | |
| | |

Client: Canine Health and Hydro Ltd

Job No: Maney-Canine

Site: Howgill Farm
Howgill Lane
Rimington
Clitheroe BB7 4EF

Project: Car Park, Access, Seating, Cabin and signage

Status: Planning B

plans and planning

Apartment 2
Rimington House
Rimington Lane
Rimington BB7 4DS

Email - pfkirk@gmail.com Tel - 07710 020611
www.plansandplanning.co.uk

Drawing No: P102 - 18/03/25

Drawing: Cabin Elevations and Sign

Print to Scale on A1 17/03/2025 16:56:31