

### THE BIKE STORE COMPANY - AMAZON ECO CYCLE SHELTER 1:50

- Standard dimensions: 3345mm x 2200mm x 1200mm
- Open fronted sliding gate
- Black Powder coated frame
- Variety of locking options
- Timber clad finish - Fire Treated
- Profile roof sheeting
- Underground or overground fix

100 thick C20 grade concrete slab, reinforced with a393 mes. Local thickening to raised end identified on drawing above.

Site with 50mm sand blinding on 100mm crush sub-base material. Subject to BCO approval.

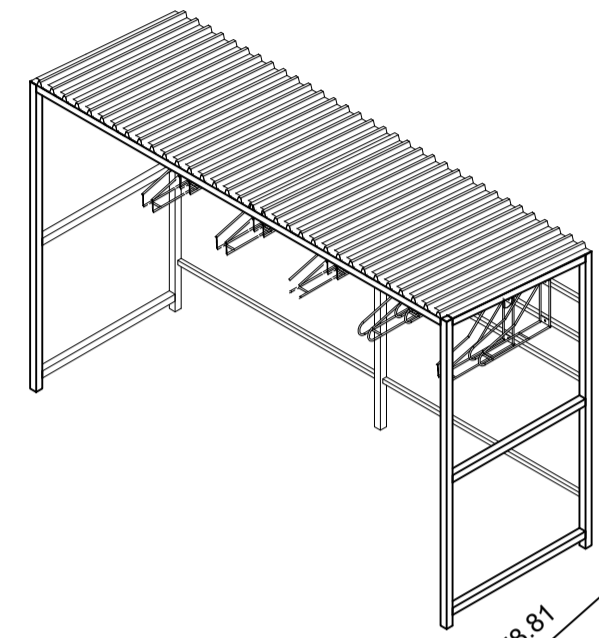

79.04



### SITE PLAN AND RAISED KERB 1:50

The scheme for the site access and off-site works of highway mitigation, which includes the proposed alteration of the existing Traffic Regulation Order along the site frontage and formation of a crossover at the redundant site access

### NEW ENTRANCE GATES 1:20

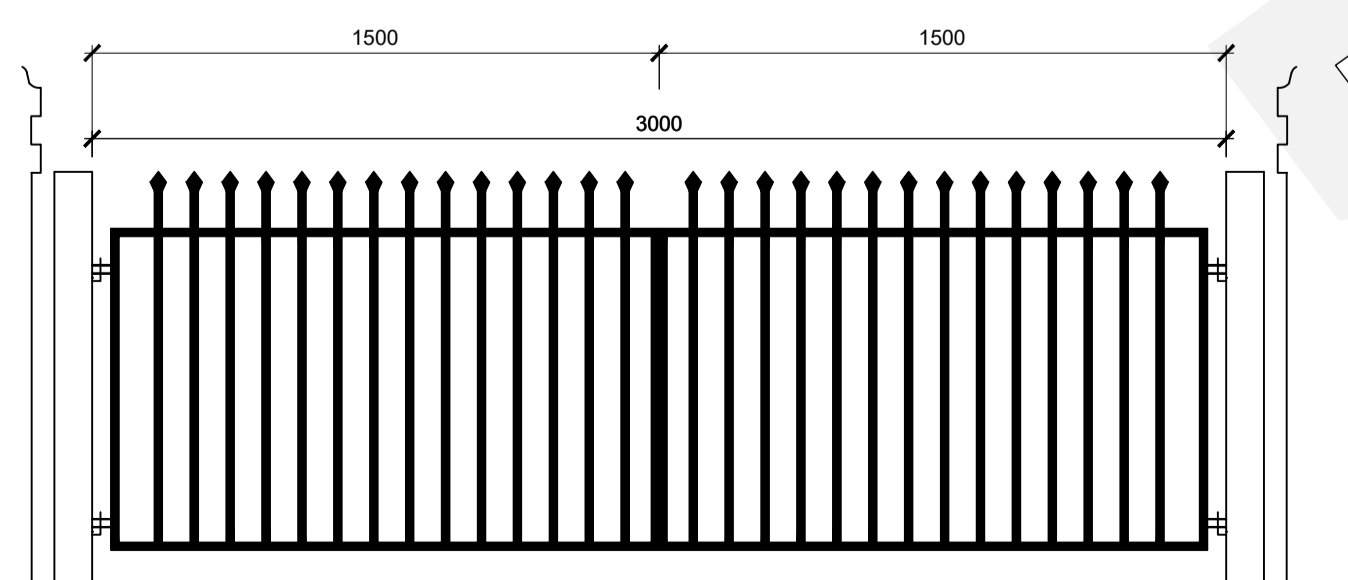

1100mm railing : <https://www.gardenoasis.co.uk/gates-and-railings/manor-flat-top-double-gates>  
Or similar

### NOTES AND AMENDMENTS

This drawing is copyright ©. Figured dimensions are to be followed in preference to scaled dimensions and particulars are to be taken from the actual work where possible. Any discrepancy must be reported to the architect immediately and before proceeding.

### REVISIONS

Rev	Description	Drawn	Date
A	Client Landscaping changes	AJB	18.09.24
B	Flat 4 Patio enlarged	AJB	18.10.24
C	Site revisions	AJB	01.11.24
D	Site revisions	AJB	21.11.24
E	Gates	AJB	04.12.24
F	Gates and Railings	AJB	19.02.25

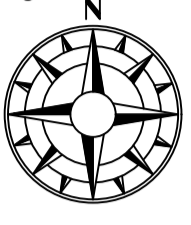

### Key

- 600 x 600mm concrete slabs to bin store
- Paving flags to match existing footway
- Crossing
- New Kerb stones
- Demolished
- Paving flags to new patio

2222 Rosendale House, Clitheroe					
External works areas					
Item	Ex. Total	Lost	Gained	Difference	Total units
Grass	81.8	24.5	41.8	17.3	99.1 m2
Hedge	33.6	4.6	3.5	-1.1	32.5 m
Patio	31.5	18.2	82.4	64.2	95.7 m2

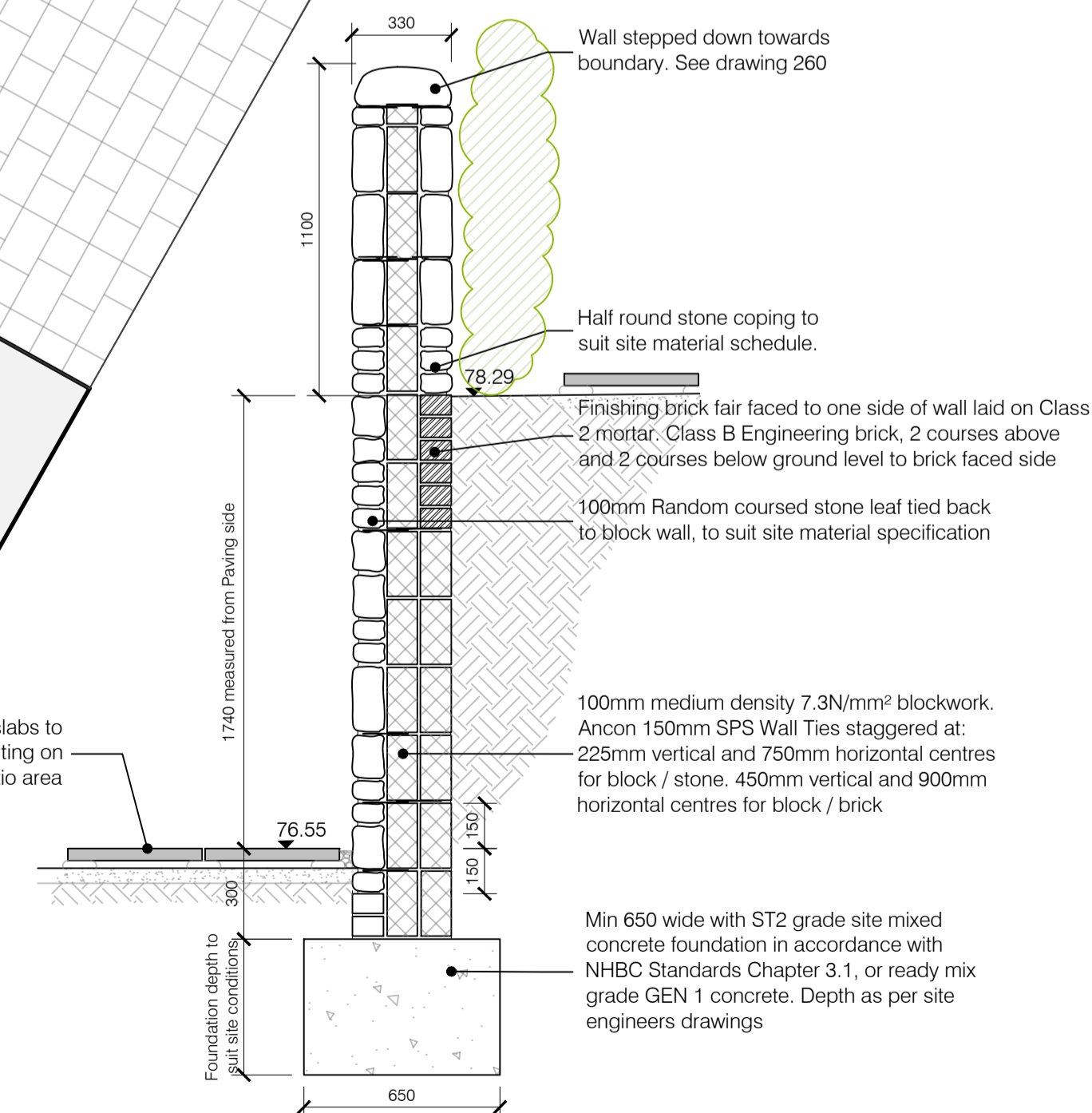

RETAINING WALL 1:20

## ASHWOOD DESIGN ASSOCIATES LTD

Unit Gb, Clifford Court  
Cooper Way  
Carlisle  
CA3 0JG

t 01228 510616  
e admin@ashwooddesign.co.uk  
w www.ashwooddesign.co.uk

### PURPOSE: PLANNING

Client:  
CJP North West

Project:  
Rosendale House  
Conversion to flats

Title:  
Proposed Site Plan

Scale	Sheet Size	Drawn	Date
1/50	A3	AJB	06-24
Project No.	Drawing No.	Revision:	
2222	80	F	