

5.1

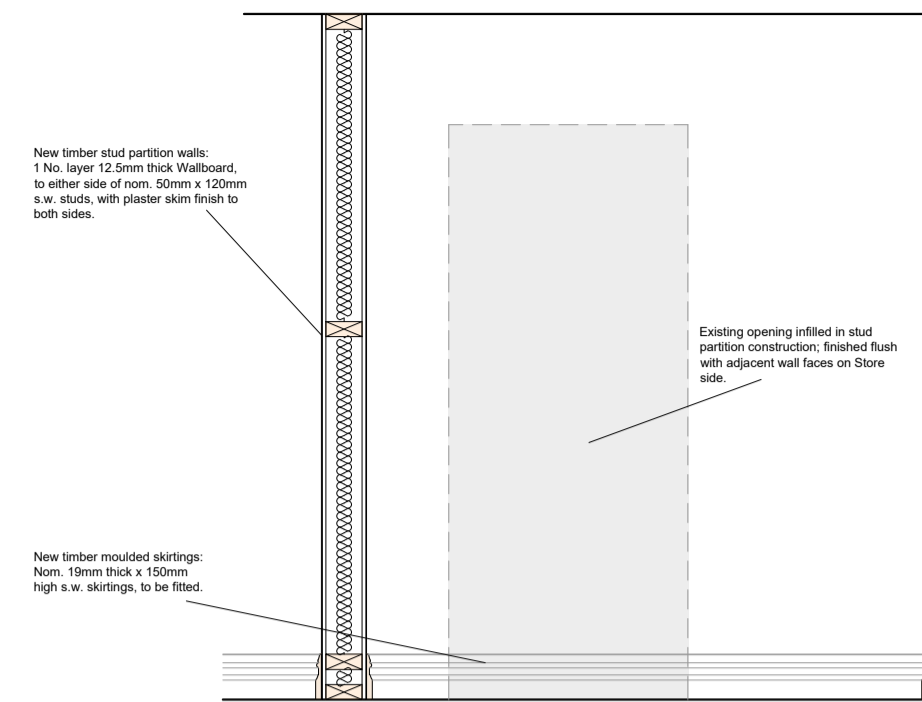

Store (Adjacent to Pantry).
Scale 1:25

5.1

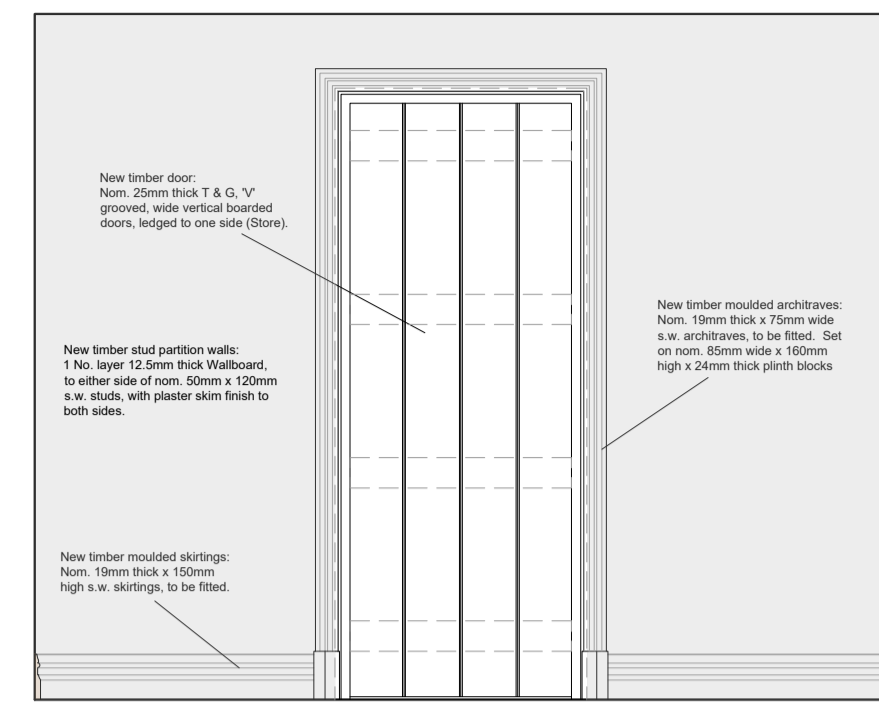

Pantry (Looking Towards Store).
Scale 1:25

5.1

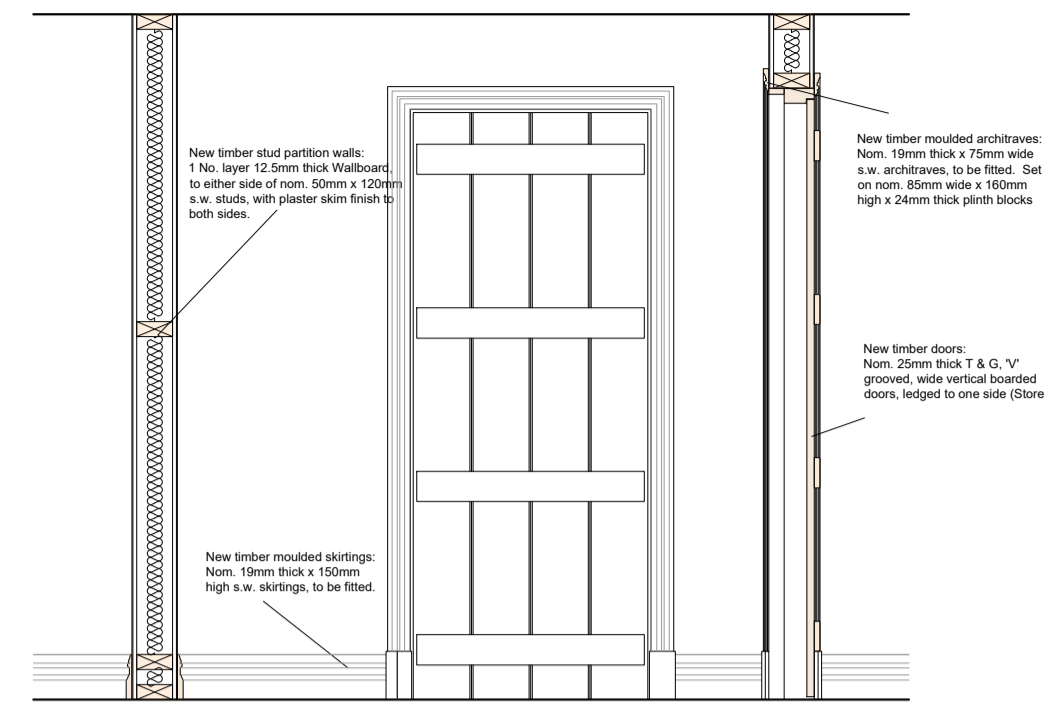

Section Through Pantry (Looking Towards Kitchen).
Scale 1:25

5.6

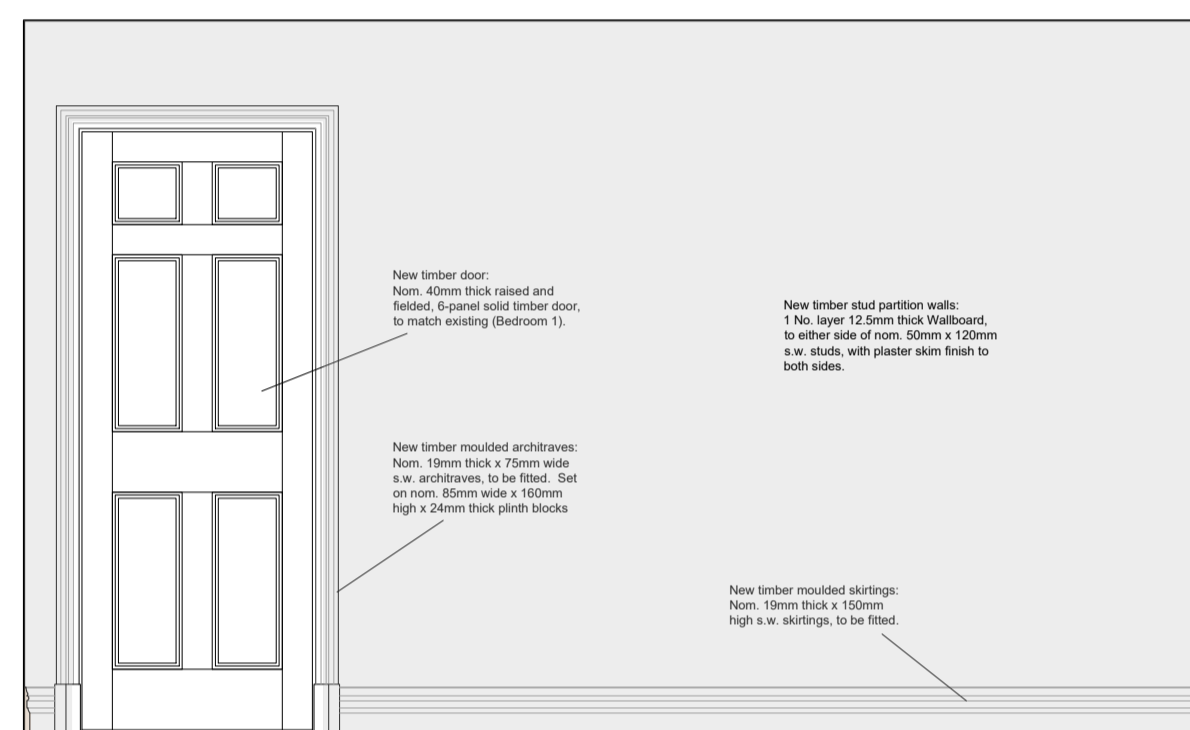

Bedroom 1 (Looking Towards FF Landing).
Scale 1:25

5.11

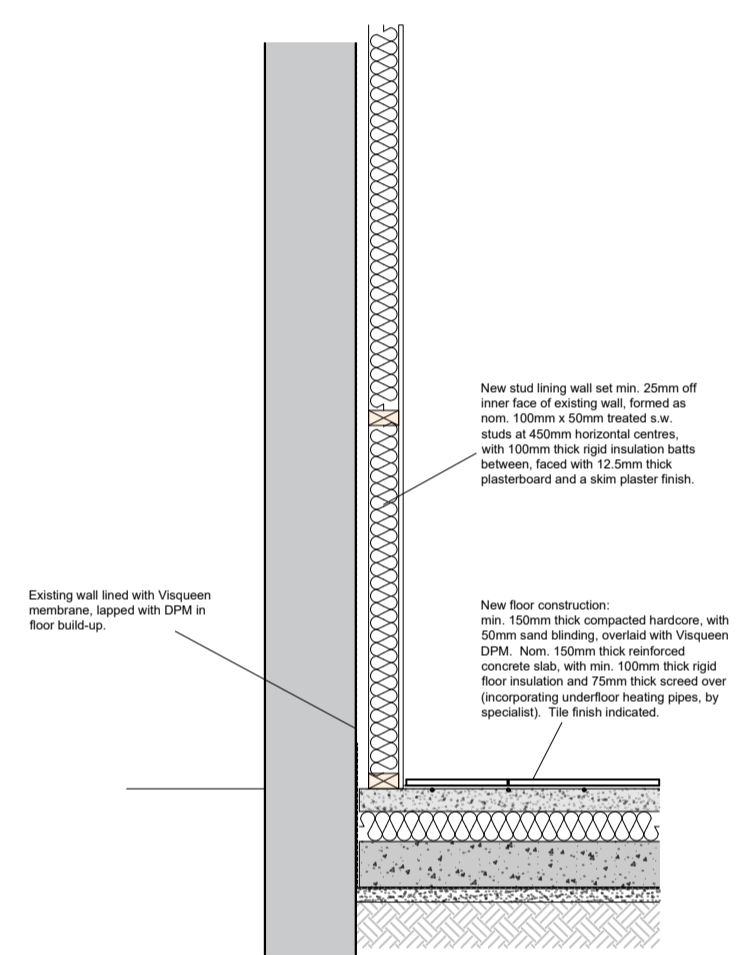

Outbuilding Floor and Lining Wall.
Scale 1:25

5.12

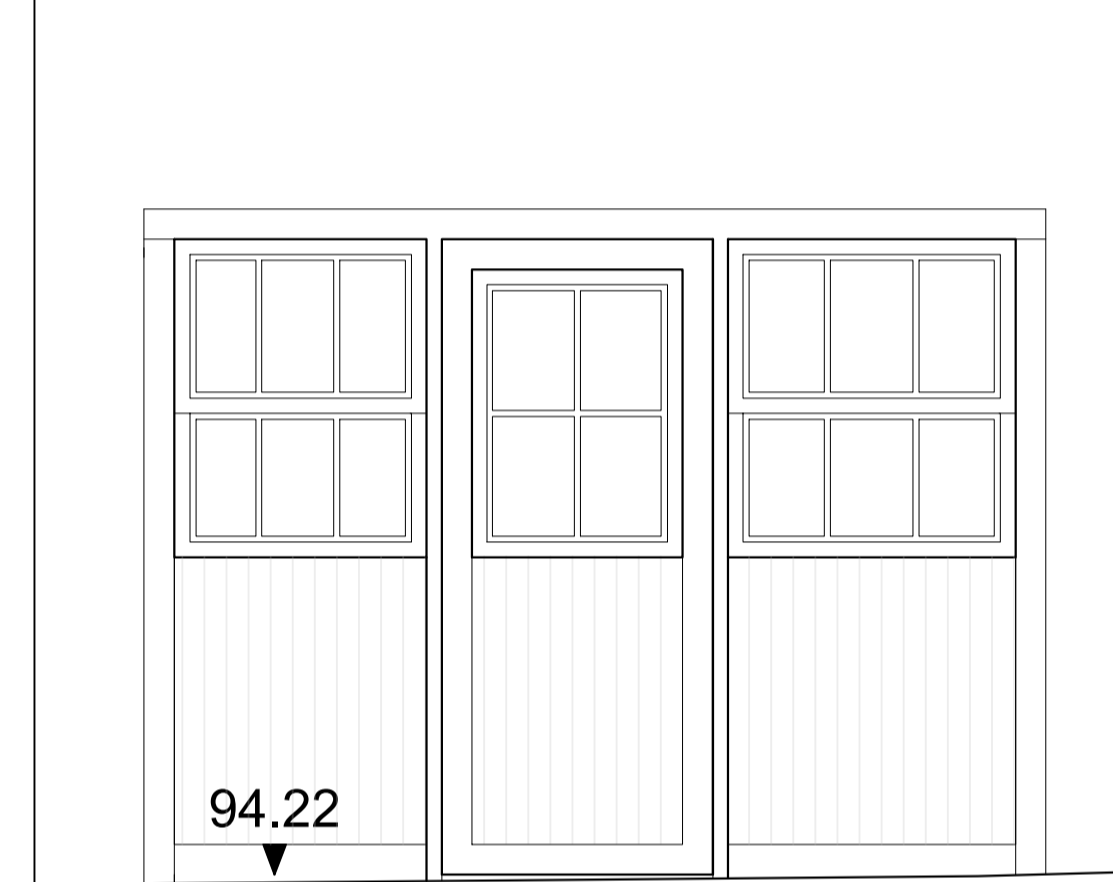

Outbuilding External Door Alterations
Scale 1:25

5.13

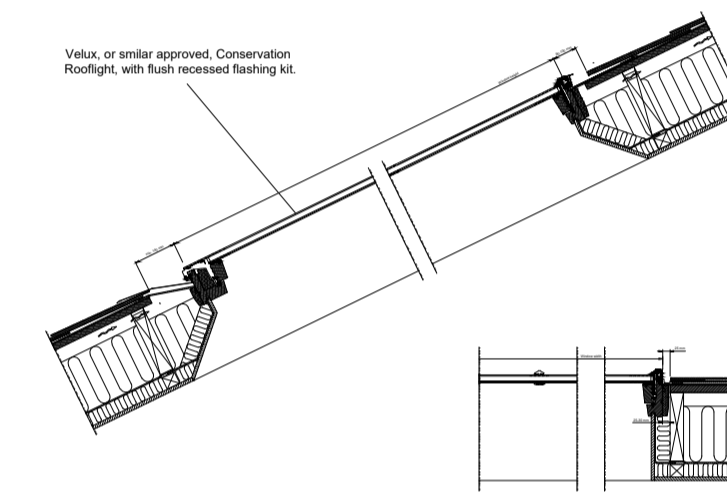

Outbuilding Typical Conservation Rooflight.
Scale 1:25

5.13

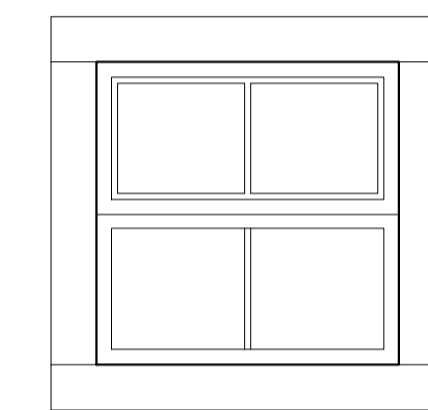

Outbuilding Window to West Elevation.
Scale 1:25

5.13

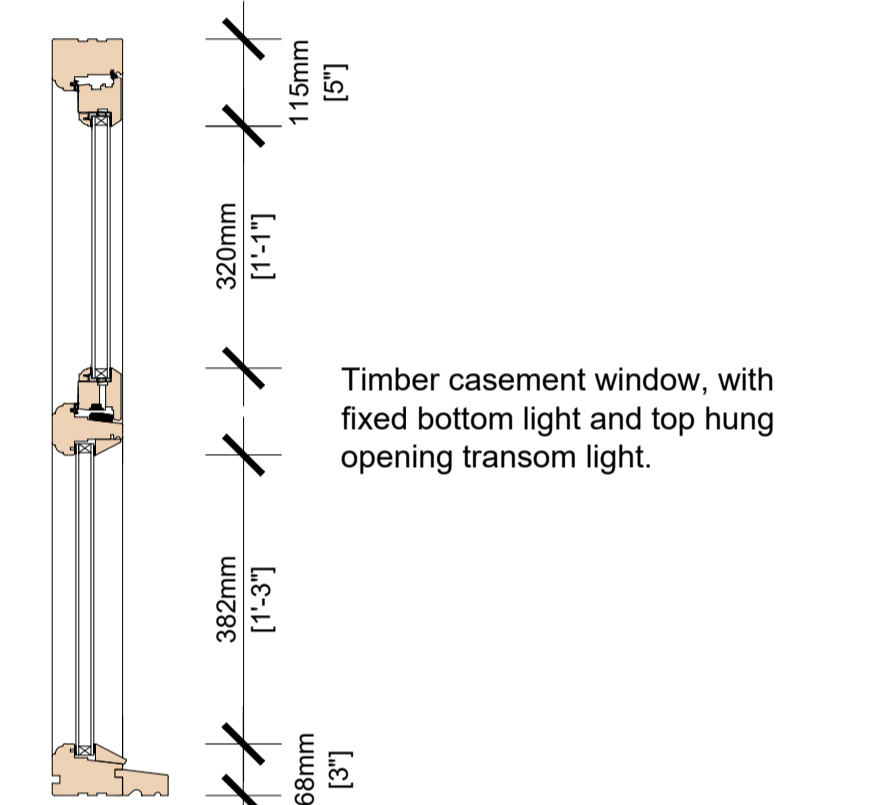

Proposed Section Through Casement Window
Scale 1:10

5.14

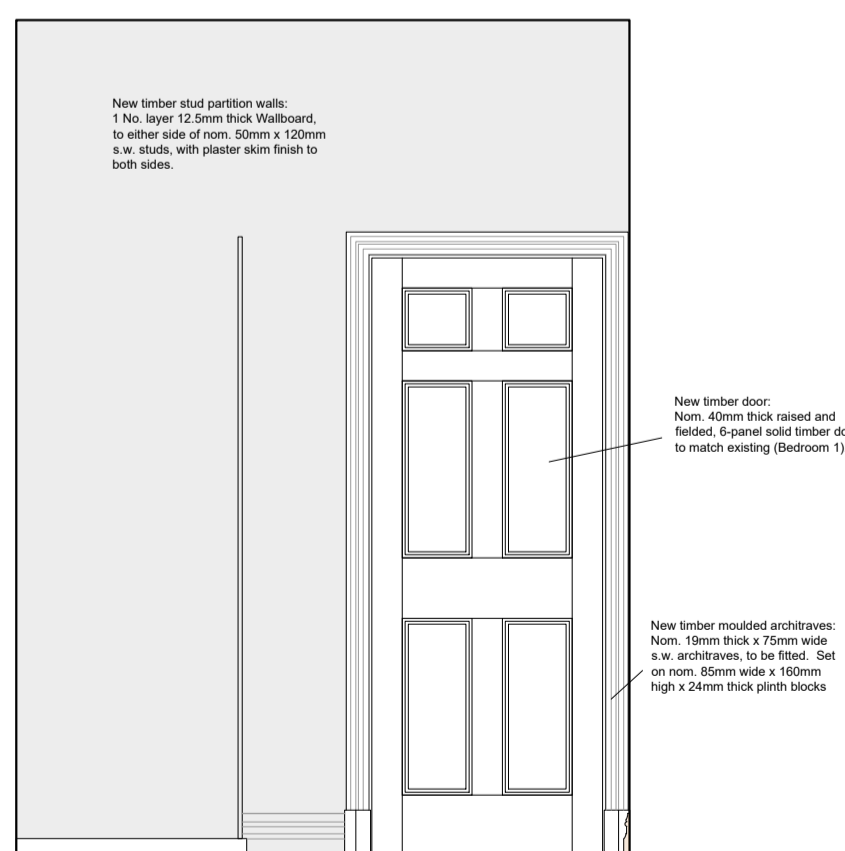

Bedroom 5 En Suite (Looking Towards Bedroom 5).
Scale 1:25

6.1

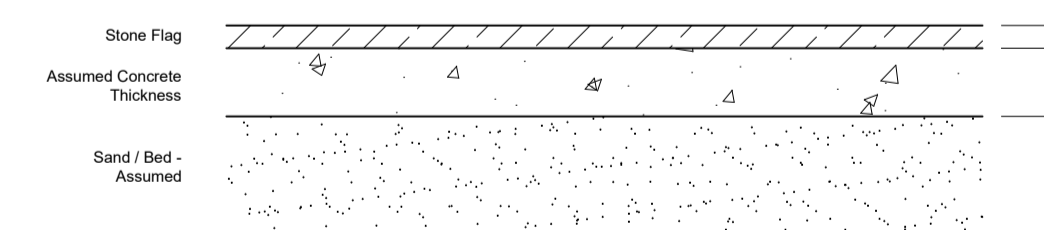

Existing Floor Build-Up.
Scale 1:10

6.2

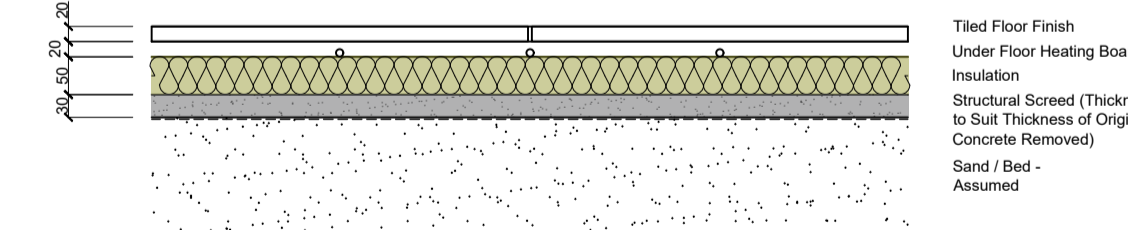

Proposed Floor Build-Up.
Scale 1:10