



Acoustic Survey and Odour Assessment for Proposed change of use of industrial unit at Bee Mill, Ribchester, PR3 3XL.

Prepared for:

Freda's Peanut Butter Ltd,
Ley Cottage,
St Neot,
Cornwall,
PL14 6PE.

October 2025



Contents

1. Introduction	3
Site Location and Context	3
2. Policy and Guidance.....	4
Noise	4
Odour	8
3. The Assessment	10
The development	10
Noise	10
Existing Situation.....	10
Anticipate Sound Emissions from the development	11
Odour	12
Assessment of potential odour emissions	12
4 Conclusion.....	14
Noise	14
Odour	14
Figure 1 – Aerial Photograph	15
Figure 2 – Proposed Layout Plan.....	16
Appendix A – Full Monitoring Results.....	17
Appendix B - Report Author Details.....	18



1. Introduction

- 1.1. Martin Environmental Solutions has been commissioned to undertake an acoustic survey and odour assessment to support a planning application for the change of use of an industrial unit at Bee Mill Ribchester PR3 3XL into a food manufacturing site.

Site Location and Context

- 1.2. The development site is situated to the northeast of the business Park with adjoining units to the north and south, with other units to the west. To the east beyond the access road and parking land are residential properties. The main road runs to the north with housing and a public house on the far side of the road.
- 1.3. An aerial Photograph is enclosed in Figure 1, together with a proposed layout drawing in Figure 2.
- 1.4. The report has been produced to clarify the potential impact on the proposed development and to identify mitigation measures if required to ensure the development is appropriate in terms of noise impact.



2. Policy and Guidance

Noise

- 2.1. The impact of noise can be a material consideration in the determination of planning applications. The planning system has the task of guiding development to the most appropriate locations. It is recognised that on occasions it will be difficult to reconcile some land uses, such as housing, hospitals, or schools, with other activities that generate high levels of noise. However, the planning system is tasked to ensure that, wherever practicable, noise-sensitive developments are separated from major sources of noise (such as road, rail and air transport and certain types of industrial development).
- 2.2. The Government's publication of the National Planning Policy Framework (NPPF), updated in December 2024, states that planning policies and decisions should prevent new and existing development from contributing to or being put at unacceptable risk from, of being adversely affected by unacceptable levels of noise pollution.
- 2.3. The Government have also issued the Noise Policy Statement for England (NPSE). The NPSE clarifies the Government's underlying principles and aims in relation to noise and sets a vision to promote good health and a good quality of life through the effective management of noise while having regard to the Government's sustainable development strategy. The NPSE aims to mitigate and minimise adverse impacts on health and quality of life through the effective management and control of noise.
- 2.4. The NPSE introduces the following terms, although no sound levels are given to represent these, many authorities have identified the sound level criteria in line with the World Health Organisation, BS8233:2014 and BS4142: 2014 levels. The terms introduced by the NPSE are:
 - NOEL – No Observed Effect Level (<30dB(A)inside <50dB(A) outside, 10dB below background)
 - LOAEL – Lowest Observed Adverse Effect Level (30-35dB(A) inside 50-55dB(A) outside, background to +5dB)
 - SOAEL – Significant Observed Adverse Effect Level (>35dB(A) inside, >55dB(A) outside, >+10dB above background)
- 2.5. The sound levels within the brackets of the previous paragraph are those determined as appropriate levels to indicate the relevant effect levels represented by the NPSE.



- 2.6. Other commonly used examples of standards utilised by Local Planning authorities for the consideration of noise impacts include comparison of the likely noise levels to be experienced at a development, with levels that have been recommended by the World Health Organisation (WHO) as Guidelines for the prevention of Community Noise Annoyance and within BS8233: 2014.
- 2.7. The WHO recommended noise levels for outdoor amenity areas (gardens) that should not be exceeded are 55dB(A) $L_{Aeq,16hr}$ in order to avoid 'Serious Community Annoyance' or 50dB(A) $L_{Aeq,16hr}$ to avoid 'Moderate Community Annoyance' during the day. For indoor levels WHO set 35dB(A) $L_{Aeq,16hr}$ during the day to prevent Moderate Annoyance and 30 dB(A) $L_{Aeq,8hr}$ at night to prevent sleep disturbance.
- 2.8. The WHO guidance also recommends that maximum sound levels at night should not regularly exceed 45dB(A) within bedrooms to prevent sleep disturbance. Regularly is considered to be more than 10 times during any 8-hour night-time period.
- 2.9. BS 8233:2014 'Guidance on sound insulation and noise reduction for buildings' also specifies desirable noise levels to be achieved inside dwellings.
- 2.10. BS 8233:2014 'Sound insulation and noise reduction for buildings – Code of Practice' also specifies desirable noise levels to be achieved inside dwellings. BS 8233 presents two levels, the first between the hours of 07:00 – 23:00 and the second between 23:00 -07:00.
- 2.11. The daytime period suggests internal noise levels of 35dB $L_{Aeq,16hr}$, for resting in living rooms and bedrooms while for night-time a level of 30dB $L_{Aeq,8hr}$ is recommended. Criteria for external areas mirrors that within the WHO guidance.
- 2.12. Another commonly used standard is British Standard 4142:2014 'Method for rating industrial and commercial sound' compares the sound predicted by the source in question against the background, L_{A90} sound levels.



- 2.13. The "residual" L_{Aeq} measurement is then subtracted from the "ambient" L_{Aeq} measurement (with the sound source) to calculate the sound level created by the "problem" sound alone -termed the "specific" sound level.
- 2.14. If the "problem" sound is tonal, such as whine or hum, or if it is impulsive such as bangs or clatters or if it is irregular enough to attract attention a correction is added to the "specific level" to produce the "rating level". The "background" L_{A90} measurement is then compared against the "rating level".
- 2.15. If the "rating level" exceeds the "background" by around 10dB(A) or more this "indicates a significant adverse impact". A difference of around 5dB(A) 'indicates an adverse impact. The lower the commercial noise level is, the lower the likely impact.
- 2.16. In addition, the 'ProPG Planning & Noise, Professional Practice Guidance on Planning & Noise, New Residential Development' provides a 4-staged approach to undertaking a risk assessment in relation to anticipated sound levels at new residential development and the provision of mitigation measures. The guidance is principally aimed at sites exposed predominantly to noise from transportation sources.
- 2.17. The first stage consists of an initial noise risk assessment, based on indicative day and night-time *noise* levels. Simply put, the higher the ambient noise in an area the greater the impact. The levels given are shown below although it should be noted that these are in excess of both the WHO and BS 8233: 2014 guidance.



Noise Risk Category*	Potential Effect if Unmitigated	Pre-Planning Application Guidance
0 – Negligible $L_{Aeq,16hr} < 50dB$ $L_{Aeq,8hr} < 40dB$	May be noticeable but no adverse effect on health and quality of life	In this category the development is likely to be acceptable from a noise perspective, nevertheless a good acoustic design process is encouraged to improve the existing environment and/or safeguard against possible future deterioration and to protect any designated tranquil areas. A noise assessment may be requested to demonstrate no adverse impact from noise. Application need not normally be delayed on noise grounds.
1 – Low $L_{Aeq,16hr} 50-63dB$ $L_{Aeq,8hr} 40-55dB$	Adverse effect on health and quality of life	In this category the development may be refused unless a good acoustic design process is followed and is demonstrated via a Level 1 Acoustic Design Statement which confirms how the adverse impacts of noise on the new development will be mitigated and minimised and that a significant adverse impact will not arise in the finished development. Planning conditions and other measures to control noise may be required.
2 – Medium $L_{Aeq,16hr} 63-69dB$ $L_{Aeq,8hr} 55-60dB$ $L_{AFmax} > 80dB^{**}$	Significant adverse effect on health and quality of life	In this category the development is likely to be refused unless good acoustic design process is followed and is demonstrated via a Level 2 Acoustic Design Statement which confirms how the adverse impacts of noise on the new development will be mitigated and minimised, and clearly demonstrates that a significant adverse noise impact will not arise in the finished development. Planning conditions and other measures to control noise will normally be required.
3 – High $L_{Aeq,16hr} > 69dB$ $L_{Aeq,8hr} > 60dB$ $L_{AFmax} > 80dB^{**}$	Unacceptable adverse effect of health and quality of life	In this category the development is very likely to be refused on noise grounds, even if a good acoustic design process is followed and is demonstrated via a Level 2 Acoustic Design Statement. Applicants are advised to seek expert advice on possible mitigation measures. Advice on the circumstances when the refusal of a new housing on noise grounds should normally be anticipated is included in the ProPG.

2.18. Stage 2, consists of a full assessment of the prevailing ambient noise and requires 4 elements to be considered:

- I. Element 1 – Good Acoustic Design
- II. Element 2 – Internal Noise Level Guidelines
- III. Element 3 – External Amenity Area Noise Assessment
- IV. Element 4 – Assessment of Other Relevant Issues

2.19. A good acoustic design is implicit in meeting the requirements of the NPPF and can help to resolve many potential acoustic issues.

2.20. Details of the criteria considered suitable are provided above for both internal and external sound levels. Element 4 includes such issues as local and national policy, likely occupants, wider planning objectives.



Odour

- 2.21. The Government sets out its policy in relation to planning in the National Planning Policy Framework (NPPF). The NPPF states that planning policies and decisions should “preventing new and existing development from contributing to or being put at unacceptable risk from, or being adversely affected by unacceptable levels of soil, air, water or noise pollution or land instability”; and “In preparing plans to meet development needs, the aim should be to minimise pollution and other adverse effects on the local and natural environment”.
- 2.22. While Odour is not specifically mentioned in is implied by the above and the Planning Practice Guidance (PPG) note issued by the government on Air Quality states “odour and dust can also be a planning concern, for example, because of the effects on local amenity” it continues to state, “mitigation options where necessary, will depend on the proposed development and should be proportionate to the likely impact”.
- 2.23. Before an odour can be present an adverse effect, there must be exposure to the odour and therefore a source, a pathway, and a receptor without these three links no exposure can occur. In the case of this application the source is the take-away. The pathway is the air, and the receptor are the occupants of the nearby existing dwellings.
- 2.24. In assessing the impact of odour on or from a development the scale of the exposure and therefore impact is determined by the parameters collectively known as the FIDO factors (Frequency, Intensity, Duration and Offensiveness) In addition the sensitivity of the receptor (location) will determine the magnitude of the exposure. Factors that influence the magnitude of a commercial odour problem include the size/volume of the cooking facility, the type of food being prepared, and the type of cooking appliances being used.
- 2.25. Furthermore, updated guidance on assessing the impact of extraction systems from commercial kitchens has been published by EMAQ ‘*Control of Odour and Noise from Commercial Kitchen Extraction Systems*’ 2018.



2.26. This document details a methodology which should be followed to assess the potential impact from commercial kitchen extraction systems on nearby land uses and how to identify suitable control and mitigation measures as required.



3. The Assessment

The development

- 3.1 The proposed development consists of a change of use to the current industrial unit to create an internal kitchen, storage area and offices for the production of peanut butter.
- 3.2 No external works are to be undertaken and no extraction system is to be installed. Operational hours will be restricted to standard working day.
- 3.3 The production of the peanut butter involves the grinding of dry roasted peanuts (brought in bulk), into a paste. This is undertaken in small batches of ~10Kg in a Robotcoupe Blixer 30. The resulting peanut butter is then packaged and stored awaiting dispatch.
- 3.4 Figure 2 below provides an overview of the proposed development.

Noise

Existing Situation.

- 3.5 In order to obtain representative background sound levels for the area on site monitoring was undertaken over a representative period on the over the 16th October 2025.
- 3.6 A Cirrus Optimus Green sound level meter was utilised for the monitoring. The meter was placed towards the eastern boundary outside of the unit and away from reflecting objects at a height of ~1.3m.
- 3.7 The meter was field calibrated at the start and end of the monitoring period with no significant variation and full laboratory calibration certificates are available on request.
- 3.8 The weather during the monitoring was generally dry with little wind <5m/s, apart from one sort period of light rain. Sound levels obtained ranged from 51.3-54.7dB L_{Aeq,1hr} with background sound levels of 39.4-41.0dB L_{A90}.
- 3.9 Background sound levels were dominated by passing traffic on the main road.



Anticipate Sound Emissions from the development

- 3.10 Sound levels from the development are considered to be minimal. Equipment used for the grinding of the peanuts, are two small 10Kg capacity Robotcoupe Blixer 30 unit, and a depositing machine which fills the jars. Manufacturers data states sound levels for the Robotcoupe are below 70dB(A).
- 3.11 The layout of the site, see Figure 2 will see a kitchen built within the building, thus the use of the grinders will be within this enclosed space, basically in terms of acoustics a room within a room. The inside of this room will be lined to enable hygienic cleaning of the room but will in essence be a stud wall, with a sound reduction level of ~35dB R_w .
- 3.12 The outer wall of the building being of solid stone with a reduction of +68dB R_w .
- 3.13 Assuming an internal sound level of 75dB(A), above that of the Robotcoupe, and the above attenuation of the outer wall (ignoring the inner wall), the sound level 1m from the façade of the building will be 1dB, 4dB if both machines are working at once. Thus, over the 12.5m to the boundary with the nearest receptor (a 22dB reduction) the activities inside the building will not be heard.
- 3.14 The Council have requested a BS4142: 2014+A1:2019 assessment of the operations. There is no tonal noise or impact noise associated with the equipment and given the intermittent use of the Robotcoupe a 3dB correction is required to the specific sound levels.

	Day	
Measured Ambient sound level	-	Source not present
Residual Sound level	$L_{Aeq} = 51.3dB$	Lowest measurement taken
Background Sound Level	$L_{A90} = 39.0dB$	Lowest measurement taken
Reference period	60 minutes	Normal ref period,
Specific sound Level	$L_{Aeq} = -16dB$	Calculated
Acoustic feature	+3dB	+3dB intermittency
Rating level	-13dB	
Background sound level	$L_{A90} = 39dB$	



Excess of Rating level over background level	(-13-39) dB = - 52dB indicates no significant adverse impact	
Uncertainty		A higher than expected internal sound level has been used, with no reduction for internal walls applied.

- 3.15 The assessment; shows that the development will not result in any adverse impact on the future residents.
- 3.16 The only other source of noise is the delivery and dispatch operations. However, these are not dissimilar to those already permitted and undertaken on the site, with deliveries being less frequent and dispatch undertaken by a small van, with material moved by hand.

Odour

Assessment of potential odour emissions

- 3.17 The production of peanut butter operations will involve grinding of peanuts within an enclosed machine in small batches of 10Kg. this is then transferred to the dispensing machine for jar filling.
- 3.18 All production activities will be undertaken within the enclosed kitchen are, which is cleaned down at the end of each production shift. No cooking or heating of the peanuts is undertaken as part of the process. Potential odour generation is therefore minimal.
- 3.19 No extraction is to be installed as part of the development. The kitchen area is to be enclosed and built within the existing structure. Odour emissions are therefore considered to be negligible.
- 3.20 It would be normal to consider odour releases in terms of the EMAQ '*Control of Odour and Noise from Commercial Kitchen Extraction Systems*' 2018 guidance document. However, the lack of cooking or extraction points and minimal production limits any potential odour generation or release from the building and the guidance is not therefore suitable for this development.



- 3.21 The Institute of Air Quality Management guidance document '*Guidance on the assessment of odour for planning*' identifies that there must be a source, pathway and receptor for any odour to present an adverse impact. The development will not produce any odour outside of the kitchen area, and then only a slight odour as would be expected in a domestic setting when opening containers.
- 3.22 The potential source is negligible; there is no pathway present with all activities undertaken within an enclosed kitchen area without extraction and the receptor will be located over 20m from the production area, with intervening enclosed spaces and a clear external open area.
- 3.23 In assessing the impact of odour on or from a development the scale of the exposure and therefore impact is determined by the parameters collectively known as the FIDO factors (Frequency, Intensity, Duration and Offensiveness).
- 3.24 While the frequency of potential odours is relatively high during the short production cycles production, given the nature of the operation, lack of extraction and inner room the intensity is considered to be very low and is not offensive.
- 3.25 The potential impact is therefore considered to be minimal and no additional mitigation or control measures are considered necessary.



4 Conclusion

Noise

- 4.1 A consideration of the proposed activities and the likely internal sound levels produced has been undertaken.
- 4.2 These levels have been compared to the prevailing background sound level obtained from on-site monitoring, in line with BS4142:2014.
- 4.3 The proposed activities will not result in any adverse impact on the neighbouring properties and will ensure that the internal and external sound levels at neighbouring noise sensitive properties are acceptable and will result in a No Observe Effect in line with the Noise Policy Statement for England.
- 4.4 As such the development will meet the objectives of the National Planning Policy Framework in ensuring that no significant adverse impact is experienced by the future residents. The development is therefore considered to be acceptable in terms of noise.

Odour

- 4.5 A consideration of the potential odour generation and emissions from the proposed development has been undertaken and reference to the EMAQ '*Control of Odour and Noise from Commercial Kitchen Extraction Systems*' 2018 guidance document and IAQM '*Guidance on the assessment of odour for planning*' made.
- 4.6 Given the nature of the proposed development and the internal production area, with no external ventilation being proposed it has been identified that odour generation is minimal and odour emissions negligible. .
- 4.7 As such the development will meet the objectives of the National Planning Policy Framework in ensuring that no significant adverse impact is experienced by the neighbouring properties. The development is therefore considered to be acceptable in terms of odour.

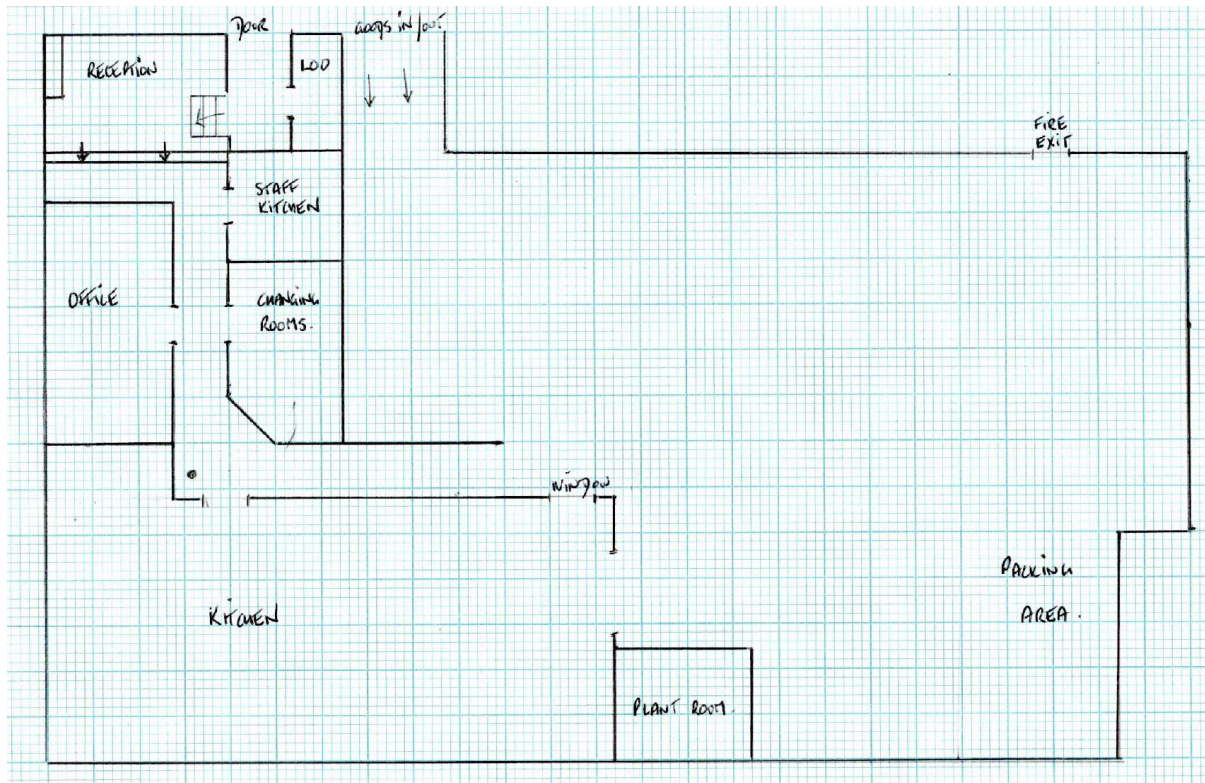

Figure 1 - Aerial Photograph





Figure 2 - Proposed Layout Plan



Appendix A – Full Monitoring Results

Time	LAeq (dB)	LA90 (dB)
20/10/2025 11:00	51.3	39.4
20/10/2025 12:00	54.7	41

Robotcoupe Blixer 30 sound levels

- « FrEquEnCY » message

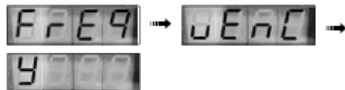

The control board cannot determine the frequency of the mains supply.

Unplug the machine and wait for 5 minutes before plugging it back in.

If this message remains on the screen, either get the control board checked over or have it replaced.

TECHNICAL SPECIFICATIONS

In order to obtain good results when mincing meat, grinding and kneading, we recommend you fill the bowl no more than half-full.

• BOWL CAPACITIES

R 23 / Blixer® 23 : 23 litres

R 30 / Blixer® 30 : 28 litres

R 45 / Blixer® 45 : 45 litres

R 60 / Blixer® 60 : 60 litres

• WEIGHT

	Net	Gross
R 23/R 30 Blixer® 23/Blixer® 30 :	110 kg	131 kg
R 45 Blixer® 45 :	138 kg	165 kg
R 60 Blixer® 60 :	150 kg	177 kg

• DIMENSIONS (in mm)

	R 23 Blixer® 23	R 30 Blixer® 30	R 45 Blixer® 45	R 60 Blixer® 60
A	1250	1250	1400	1400
B	320	360	400	450
C	600	600	600	600
D	590	590	640	640
E	1620	1620	1800	1820
F	800	800	870	870
G	700	720	760	810

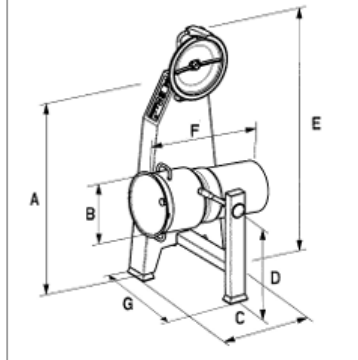

• WORKING HEIGHT

Make sure your appliance is installed on a stable work surface. There is no recommended working height, given that this is a floorstanding appliance.

• NOISE LEVEL

The equivalent continuous sound pressure level when running these appliances empty is less than 70 dB (A).

• ELECTRICAL DATA

Three-phase machine.

Model	Motor	Speed (rpm)	Nominal current (Amp)	Motor switch-on circuit * breaker + recommended differential - (Amp)
-------	-------	-------------	-----------------------	--

Blixer® 23 R 23 4500 W	400 V/50 Hz/3	1500 3000	8.5 10.5	20
	220 V/60 Hz/3	1800 3600	16.0 18.2	40
	380 V/60 Hz/3	1500 3000	8.8 10.5	20
	230 V/50 Hz/3	1500 3000	14.7 18.2	40
Blixer® 30 R 30 5400 W	400 V/50 Hz/3	1500 3000	8.5 10.5	20
	220 V/60 Hz/3	1800 3600	16.0 18.2	40
	380 V/60 Hz/3	1500 3000	8.8 10.5	20
	230 V/50 Hz/3	1500 3000	14.7 18.2	40
R 30 V.V. 5400 W	400 V/50 Hz/3	300 3000	12	20
Blixer® 45 R 45 10500 W	400 V/50 Hz/3	1500 3000	14.7 19.8	40
	220 V/60 Hz/3	1800 3600	35 27	63
	380 V/60 Hz/3	1500 3000	15.4 20.6	40
	230 V/50 Hz/3	1500 3000	24.5 35.0	63
R 45 V.V. 10500 W	400 V/50 Hz/3	300 3000	21	32

43



Appendix B - Report Author Details

This report has been produced by Neil Martin, BSc (Hons), PGDip, CEnvH MCIEH, MIOA.

Neil is the principal acoustic consultant at Martin Environmental Solutions Ltd, a consultancy company specialising in Environmental Health disciplines including environmental noise assessment and control. He holds a Bachelor's degree in Environmental Health and Diploma in Acoustics. He is a Chartered Member of the Chartered Institute of Environmental Health and a Full member of the Institute of Acoustics.

Neil has over 20 years' experience working within a Local Authority Environmental Health setting, principally in the Environmental Protection and Public Health areas and has been working as an acoustic consultant since 2011.

Since its formation, Martin Environmental Solutions has advised and assisted many groups including residents, developers and local authorities about the problems of noise and vibration in the environment and the possible solutions. Neil also acts as an expert witness in the area of acoustics.