



DNM Holdings LTD

## **Whalley Motors Site, Whalley**

### Flood Risk Assessment & Drainage Strategy

D4737-R-01 – Rev A

Dec 2025

**PSA Design Ltd**  
Consulting Engineers  
The Old Bank House  
6 Berry Lane  
Longridge  
Preston PR3 3JA

Tel. 01772 786066  
Fax. 01772 786265

[www.psadesign.co.uk](http://www.psadesign.co.uk)  
[mail@psadesign.co.uk](mailto:mail@psadesign.co.uk)

**Document Control Sheet**

**Whalley Motors Site, Whalley**  
Flood Risk Assessment & Drainage Strategy

Job	Date	Issue
D4737	20 October 2025	Original
D4737	02 December 2025	Rev A

*Originator.....G Sanderson.....*

*Checker.....D Wallbank.....*

*Approver..... G Sanderson .....*

© PSA Design Ltd. All rights reserved.

No part of this report may be copied or reproduced by any means without prior written permission from PSA Design. If you have received this report in error, please destroy all copies in your possession or control and notify PSA Design.

This report has been prepared for the exclusive use of the commissioning party and unless otherwise agreed in writing by PSA Design, no other party may use, make use of or rely on contents of the report. No liability is accepted by PSA Design for any use of this report, other than for the purposes for which it was originally prepared and provided.

Opinions and information provided in the report are on the basis of PSA Design using due skill, care and diligence in the preparation of the same and no explicit warranty is provided as to their accuracy. It should be noted that and it is expressly stated that no independent verification of any of the documents or information supplied to PSA Design has been made.

## **Contents**

### **1.0 Introduction**

- 1.1 Location
- 1.2 Existing Site & Usage

### **2.0 Development Proposals**

### **3.0 Flood Risk Assessment**

- 3.1 Flood Map for Planning
- 3.2 Vulnerability
- 3.3 Coastal Flood Risk
- 3.4 Fluvial Flood Risk
- 3.5 Surface Water Flood Risk
- 3.6 Groundwater Flood Risk
- 3.7 Reservoir Flood Risk
- 3.8 Summary of Flood Risk

### **4.0 Flood Mitigation**

- 4.1 Design Flood Level / Floor Levels
- 4.2 Flood Resistance & Resilience
- 4.3 Flood Warnings
- 4.4 Access and Egress
- 4.5 Flood Compensatory Storage Review

### **5.0 Drainage**

- 5.1 Existing Drainage Situation
- 5.2 Proposed Surface Water Management Strategy
- 5.3 Outline Drainage Design
- 5.4 Surface Water Summary
- 5.5 Proposed Foul Drainage System
- 5.6 Maintenance of Proposed SuDS Systems

### **6.0 Summary**

### **7.0 Conclusions**

## **Appendices**

- A Existing Topo Survey
  - B Architects Plans
  - C EA Flood Data
  - D GI Extracts
  - E PSA Design Drawing
  - F SW Drainage Model / Calculations
  - G Maintenance and Management Overview
-

## 1. Introduction

PSA Design have been commissioned to undertake a Flood Risk Assessment (FRA) and Drainage Strategy in support of a planning application for a proposed office development at the former Whalley Motor Services site in Whalley, Lancashire.

### 1.1. Location

The site is located at:

Whalley Motor Services,  
18 Accrington Road,  
Whalley, BB7 9TD

NGR 373475E, 436110N.

The general location of the site is shown below. It can also be seen on the Architects plans, included as **Appendix B**.

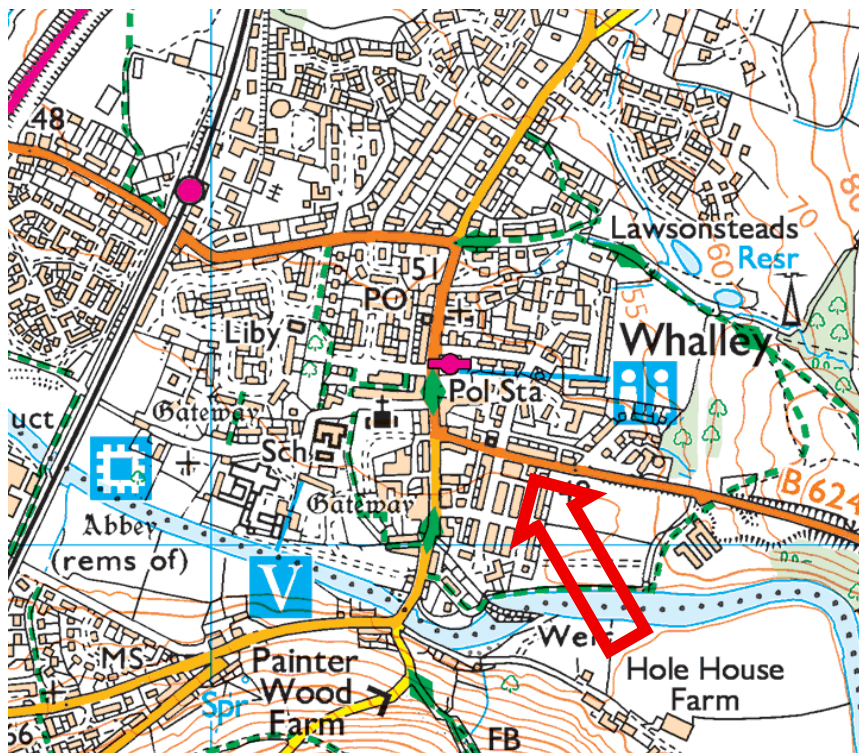

**1.2. Existing Site & Usage**

The existing site is located in the urbanised centre of Whalley and was historically was used in connection with the Whalley Motor Ltd business, a traditional motor service and repair type garage. The north of the site fronts onto Accrington Road, to the east is “Alta” nightclub and to the west and south are residential properties. The site can be seen in context on the aerial extract below.



The existing topo survey is included in **Appendix A**. The survey shows levels at the front (north) of the site at circa 47.5mAOD and the rear (south) at circa 46.0mAOD. The site is general flat east to west.

Threshold levels of the existing building also vary significantly from 48.05mAOD to the front and 45.95mAOD to the rear.

## **2. Development Proposals**

The existing building is in a poor state of repair, and it is the applicant's intention to demolish it and replace it with a modern, energy efficient office building.

The Architects proposed plans and elevations are included as **Appendix B**.

The proposals show a three-tier building construction. A basement is proposed (utilising the level difference from front to back) together with a ground floor, and a first floor in the roof space.

Finished floor levels to each floor level are as follows:

Basement – 45.42mAOD.

Ground Floor – 48.12mAOD.

First Floor – 50.92mAOD.

Access to the building will be via a single point of access off Accrington Road (i.e. 48.12mAOD). There will be no external access to the basement, access will be gained via an internal staircase off the entrance lobby.

Hours of working would typically be from Monday to Friday: 8:30am to 5:30pm and Saturday 9am to 1pm.

## **3. Flood Risk Assessment**

The Environment Agencies "Flood Risk Assessment Data" (formerly known as Product 4) has been acquired and is included as **Appendix C**.

### **3.1. Flood Map for Planning**

As can be seen from the flood mapping, the site is shown to be located within Flood Zones 2 and 3. Flood zone 2 to the north, 3 to the south. This is to be expected given the topography of the land discussed in Section 1.2 above.

Planning Policy Guidance (PPG) has been reviewed and assessed as below.

**3.2. Vulnerability**

With reference to NPPF, both the existing (motor vehicle repair garage) and proposed (office space) use would fall within the “Less Vulnerable” category. It could therefore be argued that flood risk will not be increased as the vulnerability classification will remain the same. With reference to Table 2 from PPG, if the site lies within Flood Zones 2 and 3, it would be deemed “appropriate”.

**There will therefore be no requirement for the Exception Test to be carried out for this development.**

Regardless of the above compatibility, standing advice for vulnerable developments indicates that flood risk must be assessed in detail to ensure the development is safe and flood risk is fully appraised. This is discussed in more detail below.

**3.3. Coastal Flood Risk**

Reference to the flood risk assessment data shows the site NOT at risk of coastal flooding during all scenarios.

**3.4. Fluvial Flood Risk**

Fluvial flood risk has been firstly assessed based on the flood risk data provided, the results are summarised below.

The prudent nodes are 22/23 (Front of proposed building) and 12/13 (rear of building).

Event	Node			
	12	13	22	23
<b>Defences Removed + CC 1% AEP (+15%)</b>	46.30	46.30	No Data	No Data
<b>Defended + CC 1% AEP (+15%)</b>	46.30	46.30	No Data	No Data
<b>Defences Removed 0.1% AEP</b>	47.23	47.23	47.19	47.22

**Table showing modelled fluvial event heights (mAOD)**

No Data - Cells which contain text 'NoData' for a scenario show that return period has been modelled but there is no flood risk for that return period for that

Notwithstanding the Product 4 data presented above, reference can also be made to RVBC planning application ref, 3/2022/1158, which was immediately east of our application site. The FRA associated with this scheme drew on the EA’s 2020 Flood Risk Management Scheme appraisal model developed by Mott MacDonald. The model data within it incorporates the 36% climate change allowance for the Ribble Management Catchment peak river flow allowances and is generally more detailed and accurate than the 2017 model. This model (and FRA) was subsequently accepted by the EA.

Model data extracted from the above report identified flood levels within the “neighbouring residential area”. One area that was modelled was on “Woodland View” immediately south (adjoining) to our application site (see aerial photo in para 1.2 above). The model presented a 1% AEP + 36% CC peak water level of 46.02m AOD:

Event	Peak Water Level
0.1% AEP	46.68
1%AEP +36%CC	46.02

**Table showing modelled fluvial event heights based on EA’s 2020 Flood Risk Management Scheme appraisal model developed by Mott MacDonald (m AOD)**

Reference to Section 2 above, shows FFLs for each proposed unit. The flood depths for each floor level have been directly compared to the flood levels in the tables above. Results are set out as follows, firstly compared to Whalley 2017 model, then below that compared to the 2020 FRMS model:

Proposed Floor Level	0.1% AEP Level – 47.23m AOD	1% AEP (+15% CC) Level – 46.30m AOD
Basement (45.42m AOD)	Affected (-1.81m)	Affected (-0.88m)
Ground Floor (48.12m AOD)	Unaffected (+0.89m)	Unaffected (+1.82m)
First Floor (50.92m AOD)	Unaffected (+3.69m)	Unaffected (+4.62m)

**Predicted flood depths at each property compared to Product 4 date (2017 Whalley Model)**

Note – Figures in brackets represent the level difference between floor level and food level

<b>Proposed Floor Level</b>	<b>0.1% AEP Level – 46.68mAOD</b>	<b>1% AEP (+36% CC) Level – 46.02mAOD</b>
<b>Basement (45.42mAOD)</b>	Affected (-1.26m)	Affected (-0.60m)
<b>Ground Floor (48.12mAOD)</b>	Unaffected (+1.44m)	Unaffected (+2.1m)
<b>First Floor (50.92mAOD)</b>	Unaffected (+4.24m)	Unaffected (+4.90m)

**Predicted flood depths at each property compared to Product 4 date (2020 FRMS model)**

Note – Figures in brackets represent the level difference between floor level and food level

Going forward, for the purpose of this assessment, the design flood event level at the site will be taken as 46.02mAOD (1% AEP (+36% CC) from the 2020 FRMS model). However, conclusions will indicate that comparisons to the Whalley 2017 model are also within design/risk policy requirements.

With reference to Section 2 above, the proposed building will have a single point of entry, at the ground floor level and hence no direct flood flow pathway to the basement level. Therefore, subject to suitable flood resistant measures being built into the building, the design flood event level (46.02mAOD) would be a minimum of 2.06m below the threshold level and flood flow pathway into the building.

Surrounding levels around the property threshold are maintained above 47.30mAOD along the full length of site frontage to Accrington Road. Thus, safe access and egress will be maintained at all times. Further afield, levels continue to rise along Accrington Road to the east.

**3.5. Surface Water Flood Risk**

Reference to online surface water flood risk mapping shows the site at “very low” risk.

**3.6. Groundwater Flood Risk**

Reference to online groundwater flood risk mapping indicates “Flooding from groundwater is unlikely in this area”

Review of the Ground Investigation report (extracts included in **Appendix D**) indicates shallow groundwater throughout the site. This suggests flooding from groundwater could be a viable risk. However, with reference to the conclusion made within the “Fluvial” flood risk section

above, subject to suitable mitigation measures being built into the building, flood risk from ground water would be deemed to be very low.

**3.7. Reservoir Flood Risk**

The area is shown to be in an area at risk of flooding, however, for the same reasons set out above, the site specific flood risk in for this application is considered to be very low.

**3.8. Summary of Flood Risk**

Source	Interpreted Risk Classification	Justification
Fluvial	Very Low	Subject to suitable flood mitigation measures set out above and within Section 4 below the property will be unaffected by the 0.1% AEP event. Safe access is always maintained to the property and impacts off site will be unaffected
Surface Water	Very Low	Surface water flood maps shows the site unaffected
Groundwater	Very Low	There is a risk of groundwater flooding due to shallow groundwater levels monitored in the area, however, any such event in this area would be inconsequential compared to the fluvial event
Reservoirs	Very Low	Flood from reservoirs is generally considered very unlikely, however, any such event in this area would be inconsequential compared to the fluvial event
Tidal	N/A	Unaffected

It is therefore concluded, subject to suitable mitigation measures being built into the building, the site would be safe from Fluvial flood risk. Those mitigation measures are discussed in Section 4 below.

## **4. Flood Mitigation**

### **4.1. Design Flood / Floor Levels**

The flood risk assessment above has demonstrated that the site lies within Flood Zone 2 and 3. The EA's advice on setting finished floor levels in flood zone 3 is as follows:

Proposals for 'less vulnerable' development should include floor levels are set at least 600 millimetres (mm) above the estimated flood level.

It has been demonstrated above that the only access point to the building is set 2.06m above the design flood event level (46.06mAOD).

### **4.2. Flood Resistance and Resilience**

As set out in the assessment above, whilst the access to the building is set well above the design flood event levels, the building does however contain a lower ground floor (basement). Due to the topography of the land, this floor is effectively sub-surface (i.e. a basement) at the front of the property, however, is only (circa) 500mm below ground levels to the rear. This can be seen on the Architects proposed elevation plans in **Appendix B**.

The Architects D+A statements indicates that "the basement will be fully tanked with waterproof concrete and membrane". This water-resistant construction should be continued to 46.7mAOD. This is circa 700mm above the design flood event level and above the 0.1% AEP Level.

Similarly, the windows will also need to be resistant and capable of keeping water out during a flood event, withstanding pressure up to the 46.7mAOD.



Any other openings should be kept to an absolute minimum fitted with flood resistant non-return flap valves or similar.

It is recommended the following elements are built into the basement design:

- All electrical sockets should be raised a minimum of 900mm above ground level and fed from ground floor level.
- Gypsum or magnesium oxide plaster boards fitted horizontally at ground floor.
- Lime render to be used on walls rather than traditional plaster

**4.3. Flood Warnings**

The Environment Agency is the lead organisation for flood forecasting and flood warning in England. The Environment Agency currently offers a three-stage warning service to properties at risk of flooding as outlined in the table below. The site is in a flood warning area and future occupants of the development should register for a free service to receive flood warnings direct from the Environment Agency.

Flood Warning State		Description of Flooding	Action to be taken
All Clear		Flooding unlikely	No Action
Flood Alert		Flooding is possible	Check weather forecast and Environment Agency floodline (0345 988 1188) for advice. Any external private defences such as flood guards on doorways to be erected. Alert between 2 and 12 hours before flooding
Flood Warning		Flooding is expected	Move your loved ones, pets and valuables to a safe place (vacate the building). If it is not possible to vacate, move to higher floors. Alert between 0.5 to 2 hours before flooding
Severe Flood Warning		Flooding could cause danger to life	Stay in safe place, be ready to evacuate your home and do as emergency services say. Call 999 if in immediate danger.

**Proposed Response to Environment Agency Flood Warnings**

The above table is intended as an overview of the EA’s flood warning system. Additional advice and guidance is available via the website below:

<https://www.gov.uk/guidance/flood-alerts-and-warnings-what-they-are-and-what-to-do>

**4.4. Access and Egress**

The Environment Agency aims to provide between 2 and 12 hours lead time between a flood alert being issued and possible flooding occurring. Fluvial flood risks are generally slow onset and as set out in this report safe access is available onto Accrington Road.



## 5. Drainage Strategy

### 5.1. Existing Drainage Situation

As noted above, the existing site currently comprises a 'brownfield site'. The site is 100% impermeable, consisting of buildings and paved car park/yard areas.

The existing contributing areas are shown on PSA Design drawing D4737-D-01 in **Appendix E**. In summary, 105m<sup>2</sup> drains to the north and 500m<sup>2</sup> drains to the south.

United Utilities (UU) records have been acquired and an extract included below.



The UU mapping shows two combined sewers on site, exiting to the south. There is also a large surface water sewer running westerly along Accrington Road.

To help gain further understanding of the existing site's drainage regime a CCTV survey was undertaken. The results of the surveys are reproduced below.

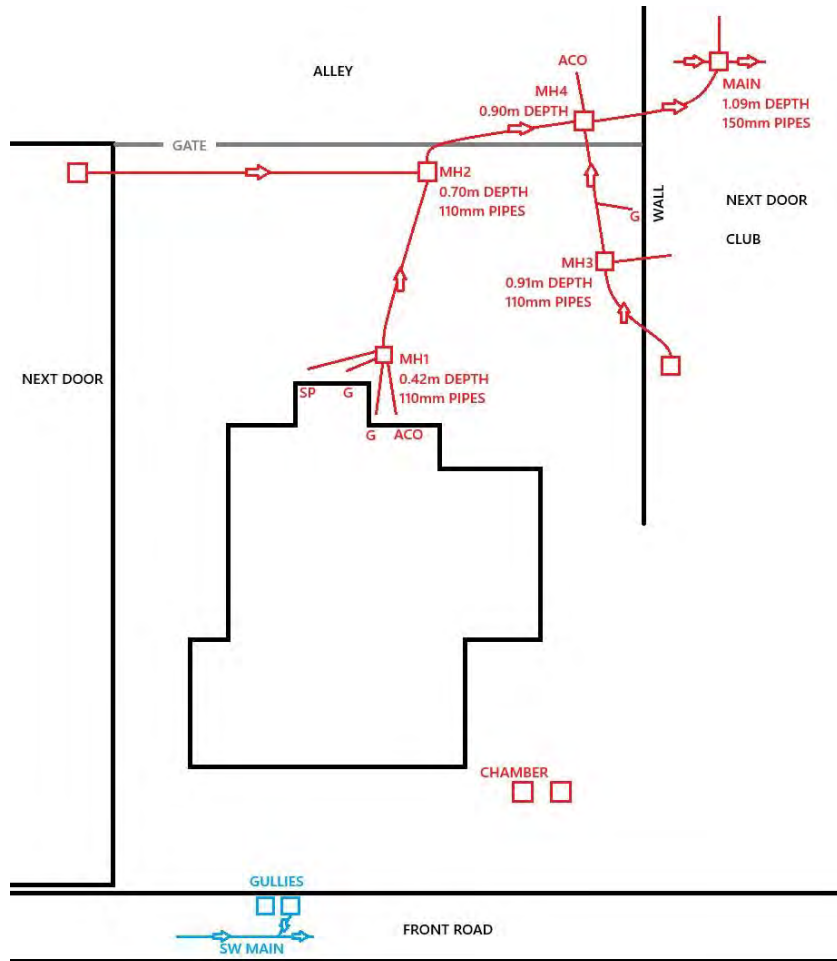

(NOTE – The plan above is shown upside down in comparison to the UU map).

The survey generally conforms with the UU mapping. The survey also picked up the existing soil pipes on site, and also the rainwater pipes and yard gullies. In summary, all the roof water and yard areas from the front façade of the building to the rear (i.e the 500m<sup>2</sup>) drains into the UU combined sewer to the south. Surface water from the paved areas to the front of the building façade (105m<sup>2</sup>), drains towards Accrington Road, into the road gullies.

The survey also picked up existing invert levels, these too have been transferred onto PSA Drawing D4737-D-01 (**Appendix E**).

For the record, the two chambers at the front of the site shown on the map above are access chambers to an old fuel tank and do not interact with the foul or SW drainage system.

**5.2. Proposed Surface Water Management Strategy**

With respect to dealing with surface water, National Planning Policy Framework (NPPF, 2024), requires that, for the range of annual flow rate probabilities, up to and including the 1% annual probability (1 in 100-year event) the developed rate of run-off from a proposed site should be no greater than the undeveloped rate of run-off for the same event. Even when the site is brownfield, if areas are being redeveloped, then the site should be treated as greenfield.

It is also important to account for climate change (CC) when making assessment of surface water run-off. As the development site is located within the Ribble Valley Management Catchment area, reference to the peak rainfall allowance map sets out the allowances below:

Scenario	Event	Central Allowance	Upper End Allowance
3.3% annual exceedance rainfall event	2050s	25%	35%
	2070s	30%	40%
1% annual exceedance rainfall event	2050s	25%	40%
	2070s	35%	50%

Catchment Peak Rainfall Allowances - Use '2050s' for development with a lifetime up to 2060 and use the 2070s epoch for development with a lifetime between 2061 and 2125.

Therefore, CC should be taken into account by increasing the proposed rainfall intensity by 40% when assessing against the 3.3% (1 in 30) storm event and 50% when assessing against the 1% (1 in 100) storm event.

Given the nature of the proposed development an urban creep allowance is not deemed necessary as the site is, and will continue to be, 100% impermeable.

There are a number of options for the provision of surface water drainage for the proposed development:

- Soakaways for roof run-off and permeable surfacing for car parks.
- Discharge to local watercourse.
- Discharge to surface water sewer.
- Discharge to combined sewer

#### Hierarchical Approach – Soakaways

Taking cognisance of the above (and in accordance with the hierarchical approach), the preferred surface water solution is to discharge to ground via soakaways. Even when there are alternative sewer connections or watercourses available, infiltration must still be utilised unless it is proved unfeasible.

Reference to the Ground Investigation report (extracts included as **Appendix D**), highlights high groundwater levels throughout the site. The GI report summarises the following:

*“Groundwater was encountered within the majority of the exploratory holes during their formation at depths between 0.3m and 2.0m bgl. During the subsequent monitoring programme, groundwater was encountered at all of the monitoring installations at depths between 0.63m and 2.34m bgl at WS105 and WS102 respectively”.*

It can therefore be concluded that soakaways would not be a viable option for draining the site.

#### Hierarchical Approach – Watercourse

The next preferred hierarchical solution for dealing with surface water run-off from a development is discharge to a watercourse. There are no known open or culverted watercourses within the direct vicinity of the site. It would not be legally or financially viable to connect to a watercourse further afield.

#### Hierarchical Approach – Surface Water Sewer

As discussed in Section 5.1 above, a 450mm dia. adopted surface water sewer runs past the site to the north. Levels in this area are however 1.5m lower than the rear of the development. For this reason, the existing site drainage outfalls south, to the lower laying combined sewer. A connection into the SW sewer would not be viable without the introduction of a pump.

Whilst this is a viable solution, pumps significantly increase flood risk and hence, given the existing site drains to the combined sewer, an outline solution has been prepared replicating the same connection point.

#### Surface Water Run-off Restriction

Regardless of this existing regime, to meet with the guidance set out above, any surface water discharge from the redeveloped areas of the site must be restricted to greenfield run-off rates. In terms of proposed drainage, the site has been split into two succinct areas (these areas are highlighted on PSA Drawing D4737-D-01 (**Appendix E**):

1. The majority of the car park / access areas will be unaffected by the proposals and continue to drain as they always have. Therefore, this area (calculated at 370m<sup>2</sup>) will remain as existing.
2. The existing building will be demolished and a new building will be constructed. The new building has a larger footprint than existing and measures 235m<sup>2</sup>. It is intended that the new SW drainage serving this area will be restricted to greenfield run-off rates.

Equivalent greenfield run-off rates on at this area would equate to <1l/s. It is therefore proposed that the minimum allowable discharge rate for the site should be restricted to 2l/s. Any rate lower than this is likely to have maintenance issues in providing a compliant solution. In any event, this rate will be discussed and approved with the relevant authority at detailed design stage

### 5.3. **Outline Drainage Design**

Whether the outfall from the proposed surface water drainage eventually discharges to the existing combined sewer, or adopted SW sewer in Accrington Road, the SuDS solution will be very similar. How the final drainage solution is taken forward will no doubt be subject to condition and can be discussed with the LA / UU at detailed design stage.

At this point, to assure a design is deliverable within the constraints of the site, as discussed above, we have assumed a final connection into the existing manhole at the rear of the site.

To restrict surface water run-off from the proposed development it will be necessary to provide some form of attenuation storage on site. There are numerous ways of providing this, the most common for small developments being cellular storage crates. The proposed surface water system should be designed to accommodate a 1 in 100 year storm event uplifted to include a 50% allowance for climate change.

The general principles of the above surface water drainage system are illustrated on PSA Design drawing D4737-D-01 (**Appendix E**). This shows a shallow "Permavoid" type attenuation tank in combination with a "Controflow" flow control chamber restricting the outfall to a maximum of 2l/s. The shallow system is necessary due to the limited clearance available to the outfall MH (at just 700mm deep).

The system has been modelled using Causeway's "Flow" software. The results are included as **Appendix F**. The results show zero flooding during the 1 in 100yr + 50% cc event.

As previously discussed, the final system will be subject to detailed design and no doubt be secured by planning condition.

**It has therefore been demonstrated that a SuDS solution that meets with the requirements of current legislation is deliverable within the constraints of the site. The final solution will of course be firmed up at detailed design stage and will in any event be secured via an associated planning condition within any subsequent outline approval.**

#### 5.4. **Foul Drainage**

New foul drainage will be connected into the existing drainage system within the site, replicating the existing situation. Pumps will likely be required to drain the WC's facilities within the basement level.

#### 5.5. **Maintenance of the Proposed SuDS System**

It is important during any development process to consider the long-term maintenance of the proposed drainage system. The proposed drainage will be maintained by the owner. If necessary, a management and maintenance plan can be secured through condition.

A typical maintenance regime has been included as **Appendix G**.

## 6. **Summary**

The existing site is brownfield. It currently (and historically) comprised a commercial business. Both the existing and proposed site uses fall within the "Less Vulnerable" category.

The existing building and business has no flood mitigation measures making it more vulnerable than the proposed redevelopment, which, as set out above, will incorporate raised floor levels and flood resistant construction measures. From an environmental perspective, the historical use also inherently imposed greater risk during a flood event, with fuels and harmful liquids stored on site associated with the garage.

The proposed threshold level is set 2.10m above the design flood event level (46.02mAOD).

Flood resistant construction methods will be built into the proposed building, including ensuring that water ingress is prevented to a minimum of 600mm above the design flood event level.

Flood mitigation measures have been defined in section 4 above which will ensure that flood risk is not exacerbated elsewhere.

The existing site is well served by foul and surface water drains. Surface water from the redeveloped area of the site (the building) will be restricted to 2l/s.

SW drainage models demonstrate no flooding of the system during the 1 in 100yr + 50%cc event.

The future business will sign up for Flood Warnings. Safe access and egress is maintained at all times onto Accrington Road and beyond.

## **7. Conclusions**

The application seeks to demolish an existing commercial building on site and re-build with a modern office building. In terms of flood risk policy, the development is deemed appropriate.

This report has methodically assessed flood risk, and where appropriate suggest mitigation measures, to ensure that the property is safe from flood risk both now and in the future.

The surface water drainage strategy outlined above shows a viable sustainable drainage solution is achievable within the constraints of the site.

All of the recommendations can be secured via suitably worded planning condition(s)

The proposed scheme can be delivered to meet with NPPF/PPG, Environment Agency, United Utilities and Local Authority requirements.

## **Appendix A**

### Existing Topo Survey



**Appendix B**  
Architects Plans

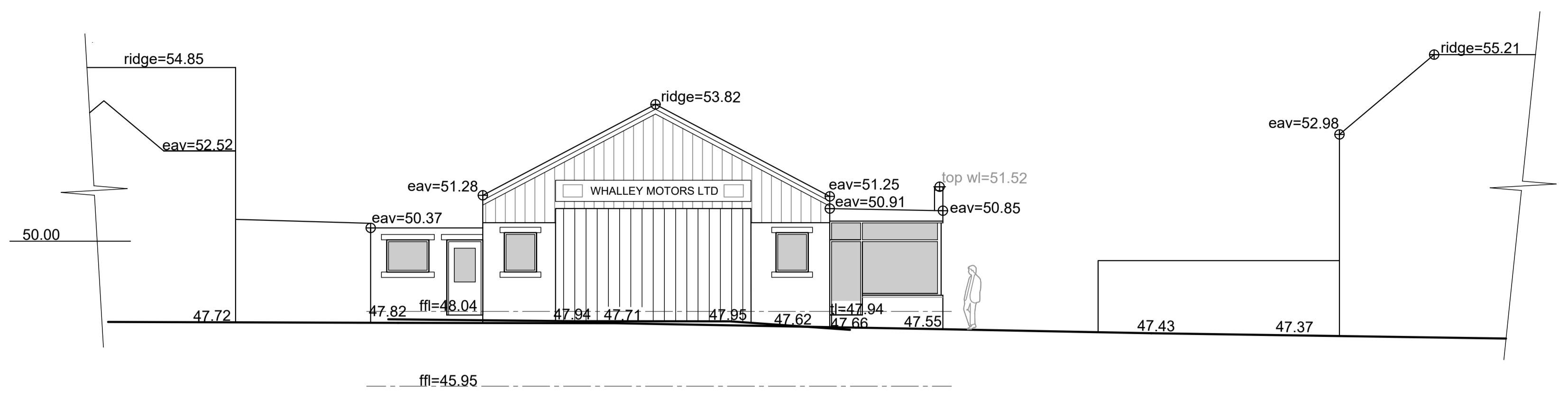

North East Elevation  
1:100 Scale

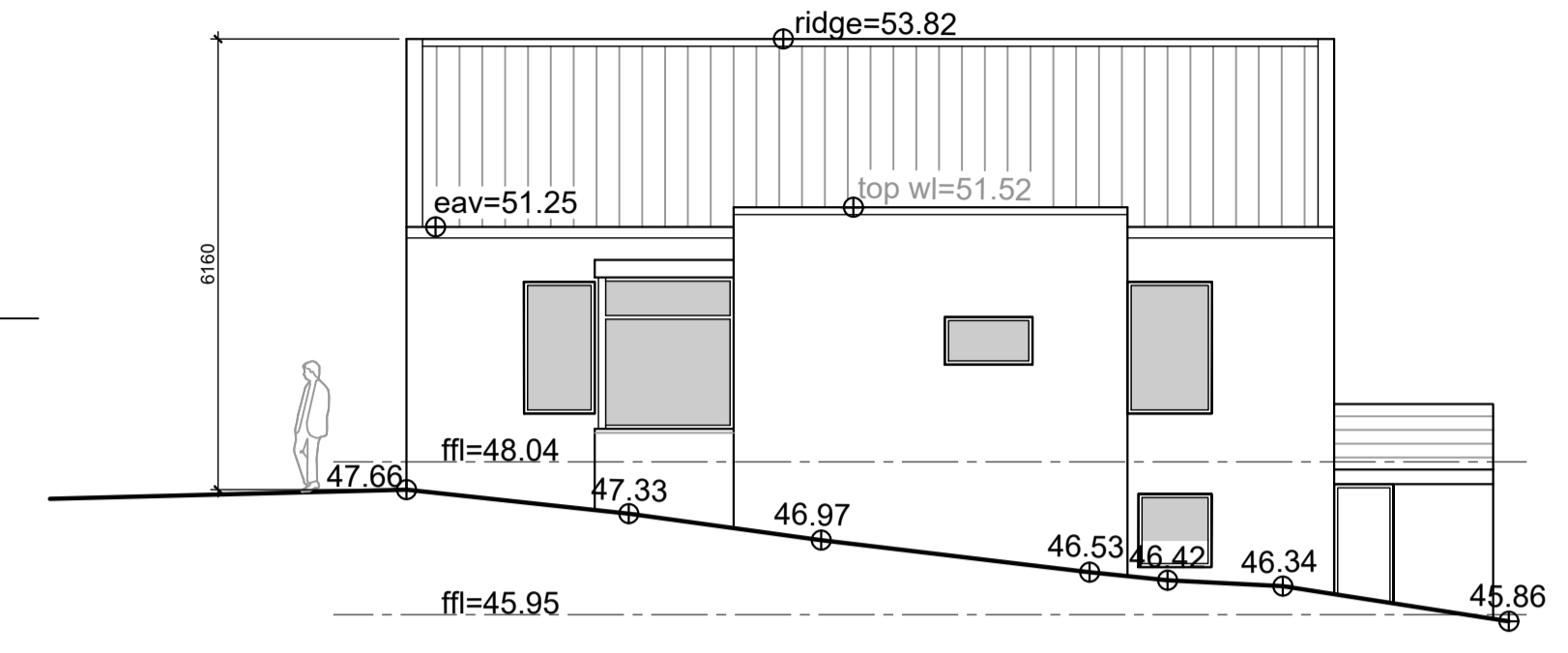

North West Elevation  
1:100 Scale

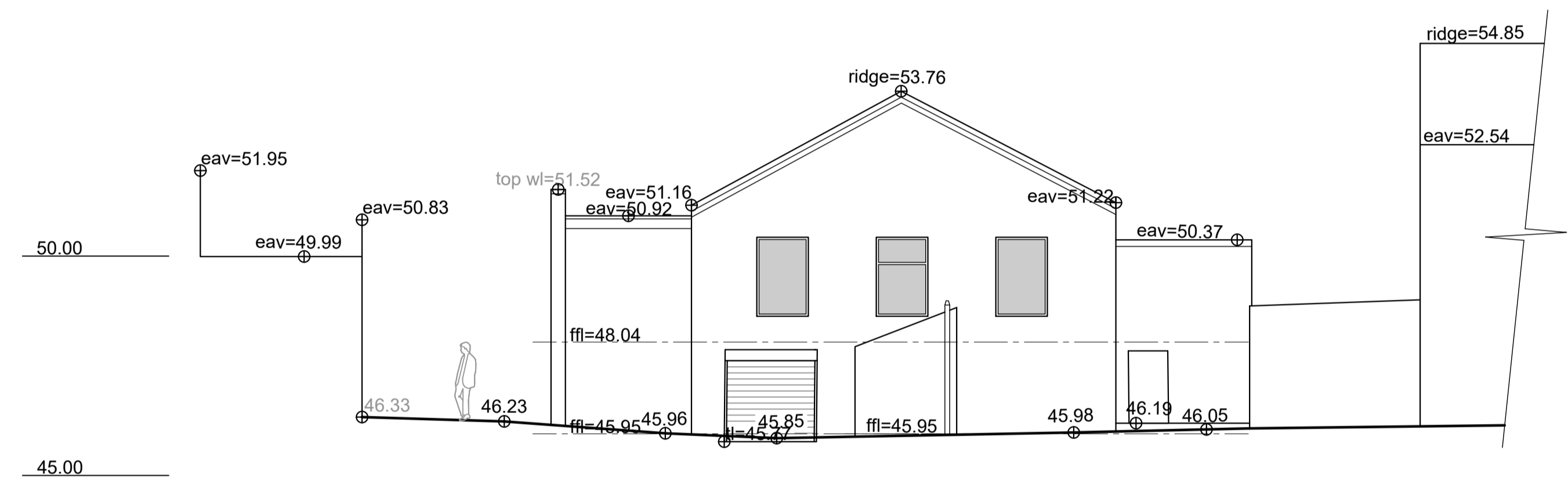

South West Elevation  
1:100 Scale



South East Elevation  
1:100 Scale

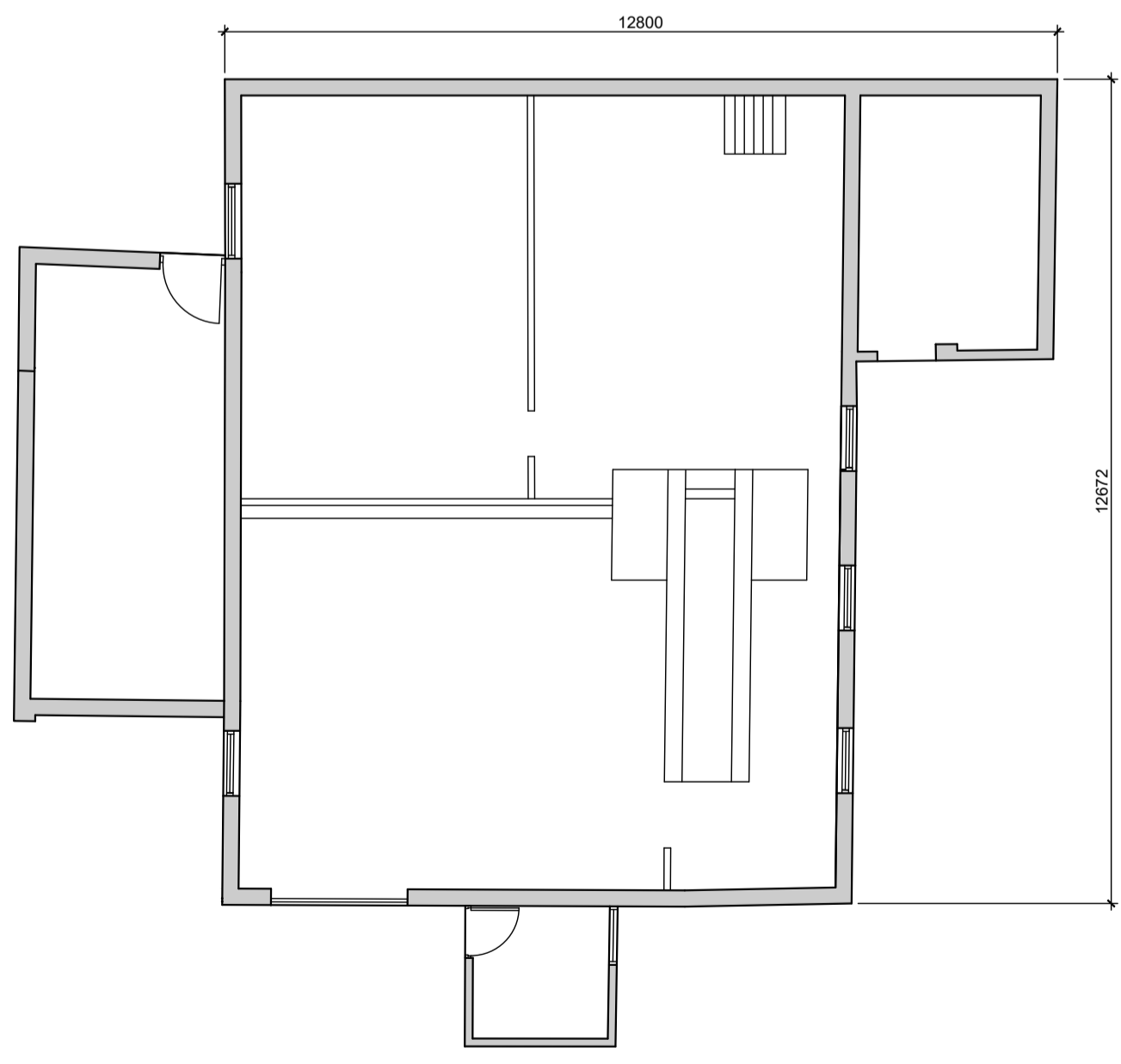

Lower Ground Floor Plan  
1:100 Scale

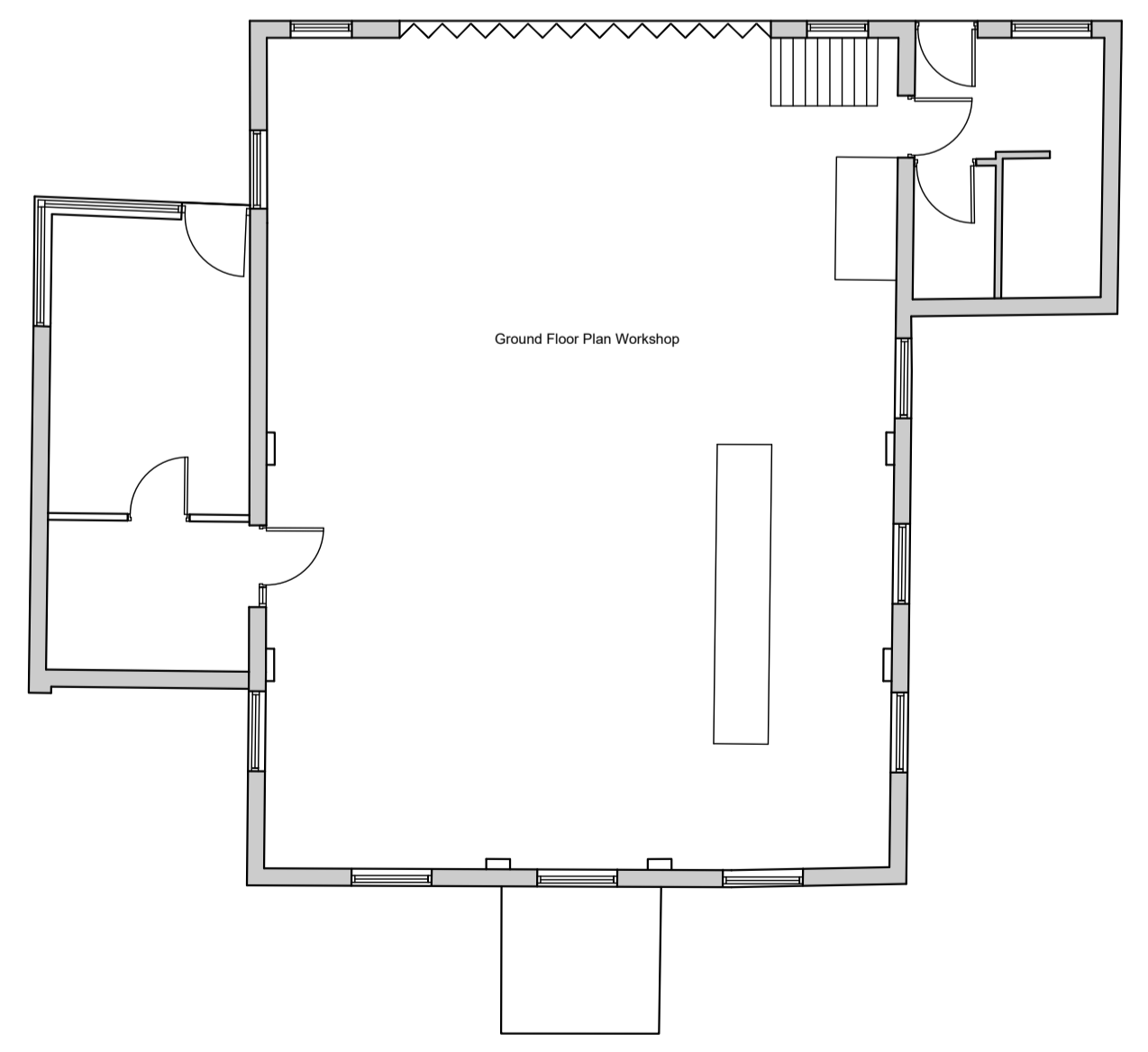

Ground Floor Plan  
1:100 Scale

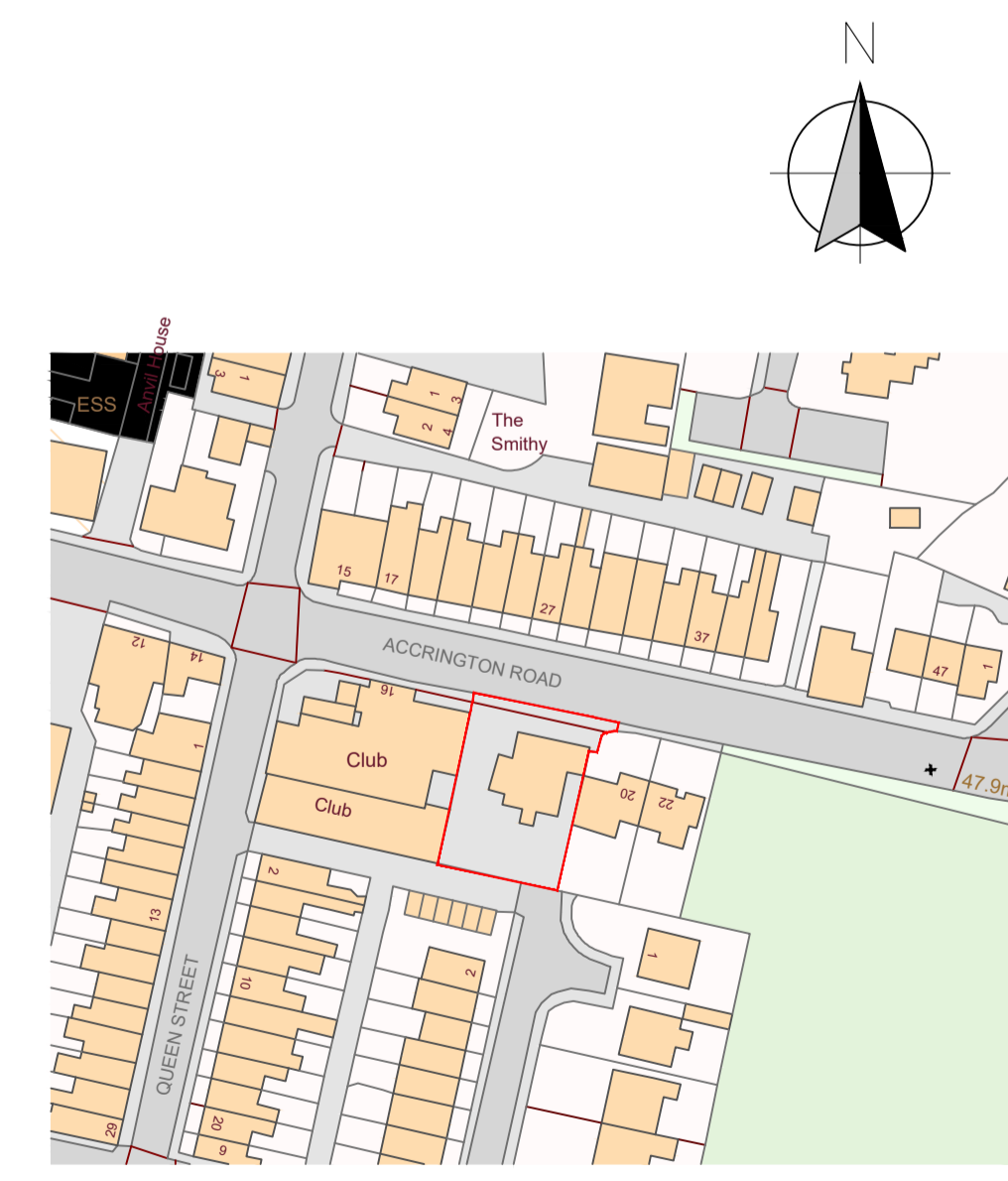

Location Plan  
1:1250 Scale



Block Plan  
1:500 Scale

Client  
Mr Daniel McGowan

Job Title  
Redevelopment of former Whalley Motor Services site into new offices at: 18 Accrington Road Whalley BB7 9TD

Drawing Title  
Existing Floor Plans, Elevations Location Plan and Block Plan

Scale  
1:100 @ A1

Date  
June 2025

Drawn  
Craig Harrison

**spa**  
SUNDERLAND PEACOCK & ASSOCIATES LTD.  
HANDLERS, PEASOCK ROAD, CLITHEROE, LANCASHIRE, BB7 3AG.  
T 01204 423718 F 01204 423728 E info@sunderlandpeacock.com www.sunderlandpeacock.com

7261-002

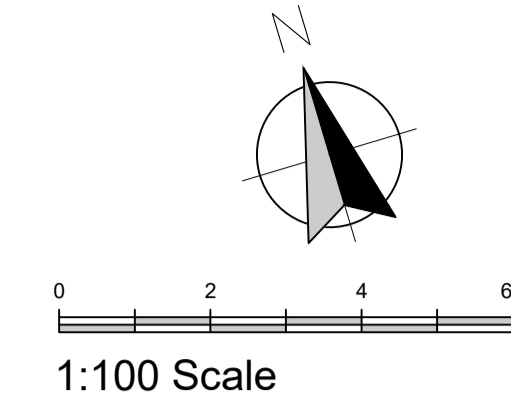

# Accrington Road

21000

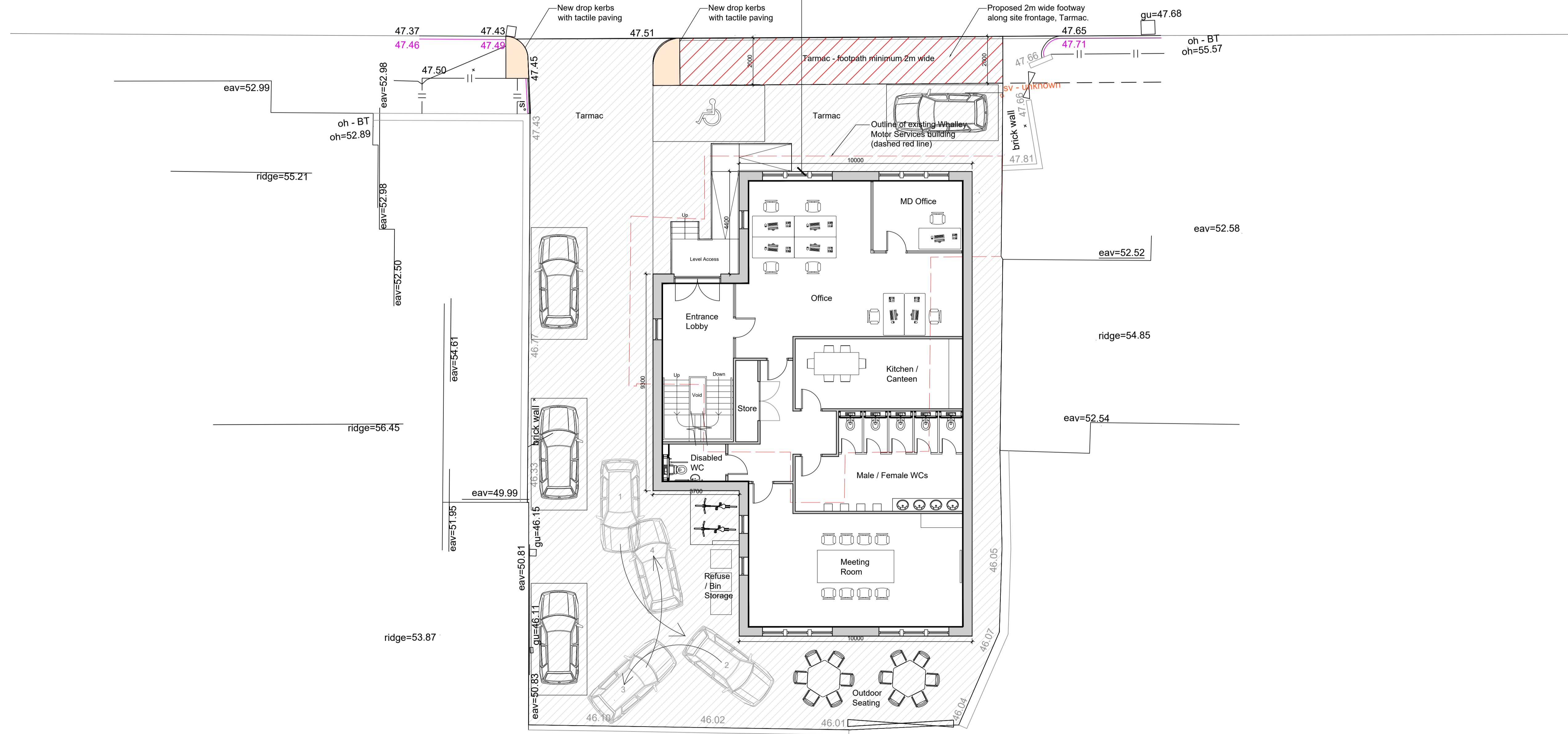

Proposed Site Plan  
1:100 Scale

Rev C. 2m wide footway added as per previous planning ref 3/2019/0831. 13.10.2025 Craig Harrison  
Rev B. Updated for Planning App. 13.10.2025 Craig Harrison

Client  
**Mr Daniel McGowan**

Job Title  
**Redevelopment of former Whalley Motor Services site into new offices at: 18 Accrington Road Whalley BB7 9TD**

Drawing Title  
**Proposed Site Plan**

Scale: 1:100 @ A1 Date: June 2025 Drawn: Craig Harrison

**spa**  
SUNDERLAND PEACOCK & ASSOCIATES LTD.  
HARDENERS, PRINCE ROAD, CLITHEROE, LANCASHIRE, BB7 3AG.  
T: 01204 423718 F: 01204 421728  
E: info@sunderlandpeacock.com  
www.sunderlandpeacock.com

**7261 -003C**



North East Elevation  
1:100 Scale

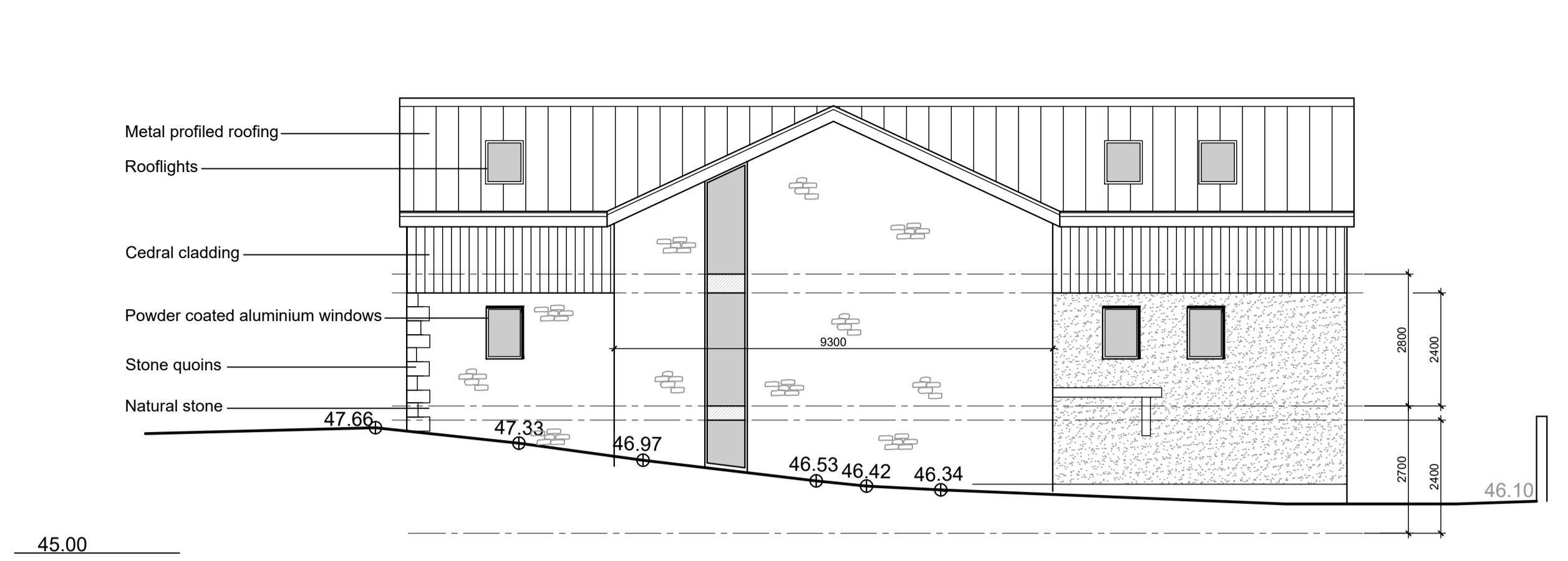

North West Elevation  
1:100 Scale



South West Elevation  
1:100 Scale

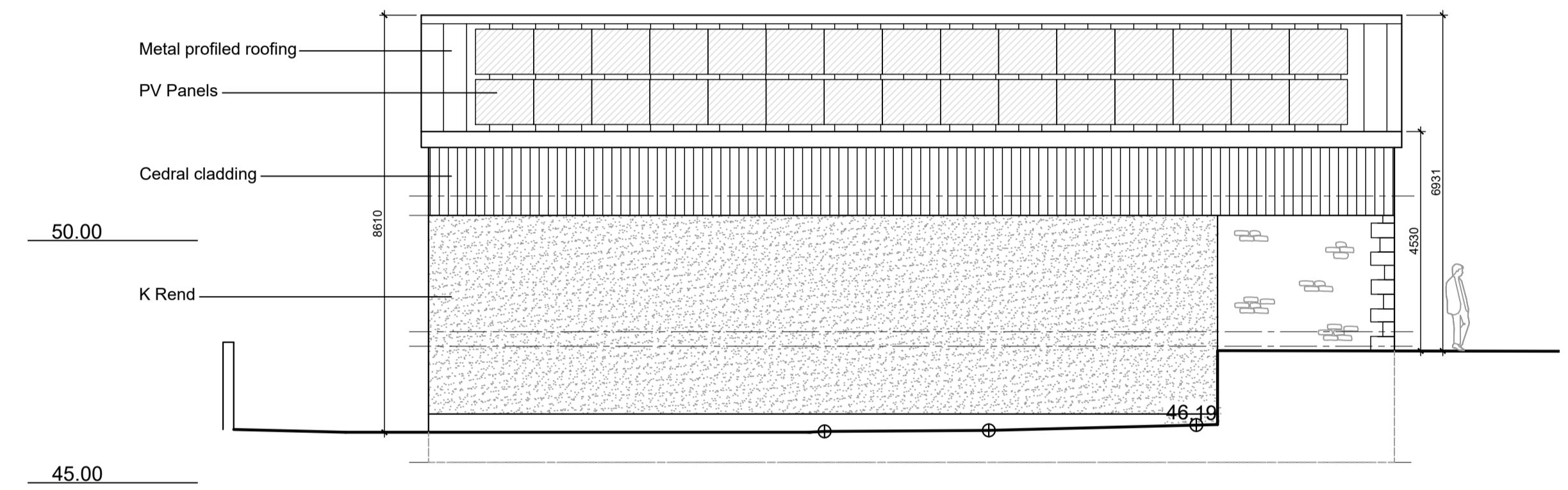

South East Elevation  
1:100 Scale

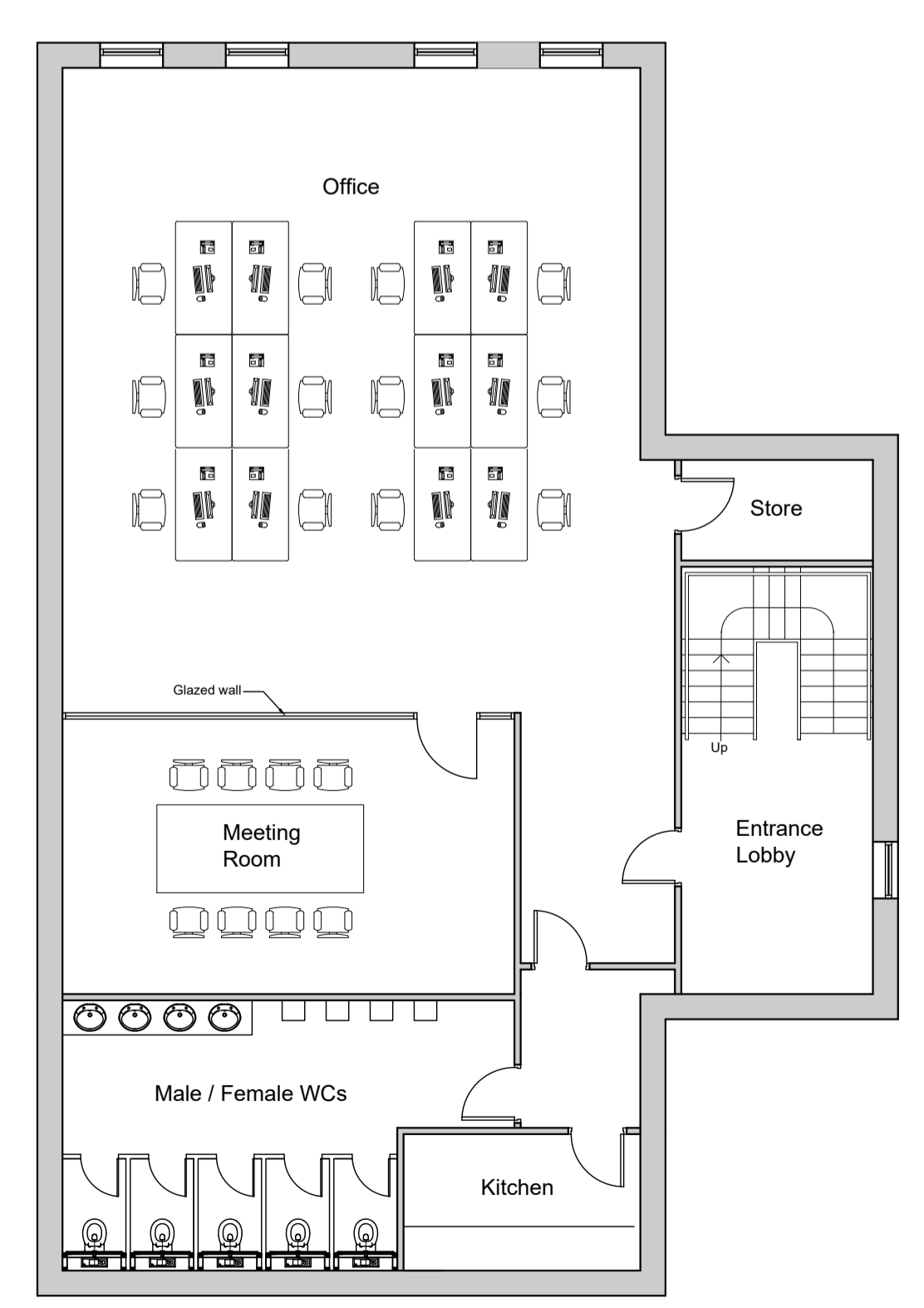

Lower Ground Floor Plan  
1:100 Scale

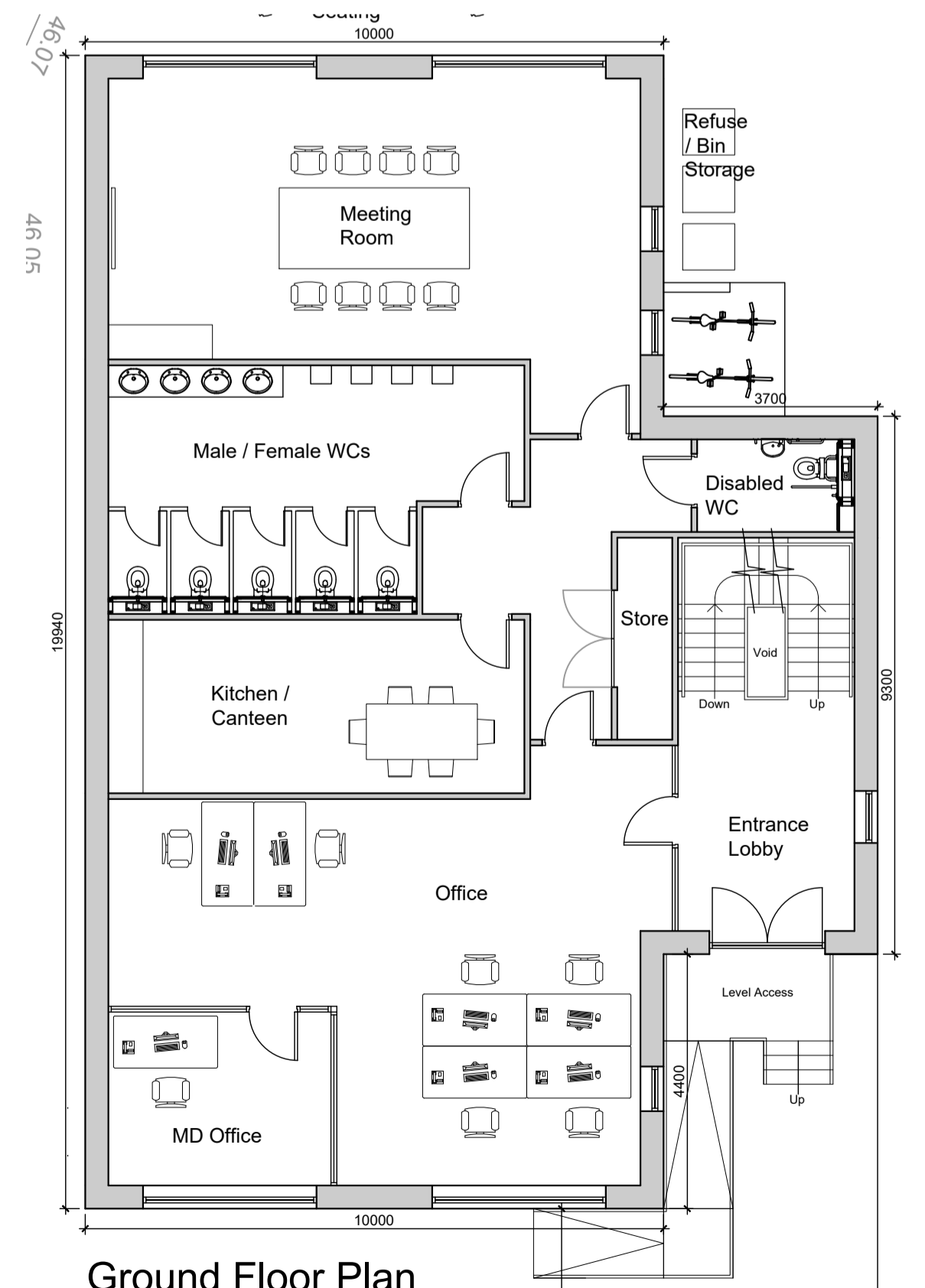

Ground Floor Plan  
1:100 Scale

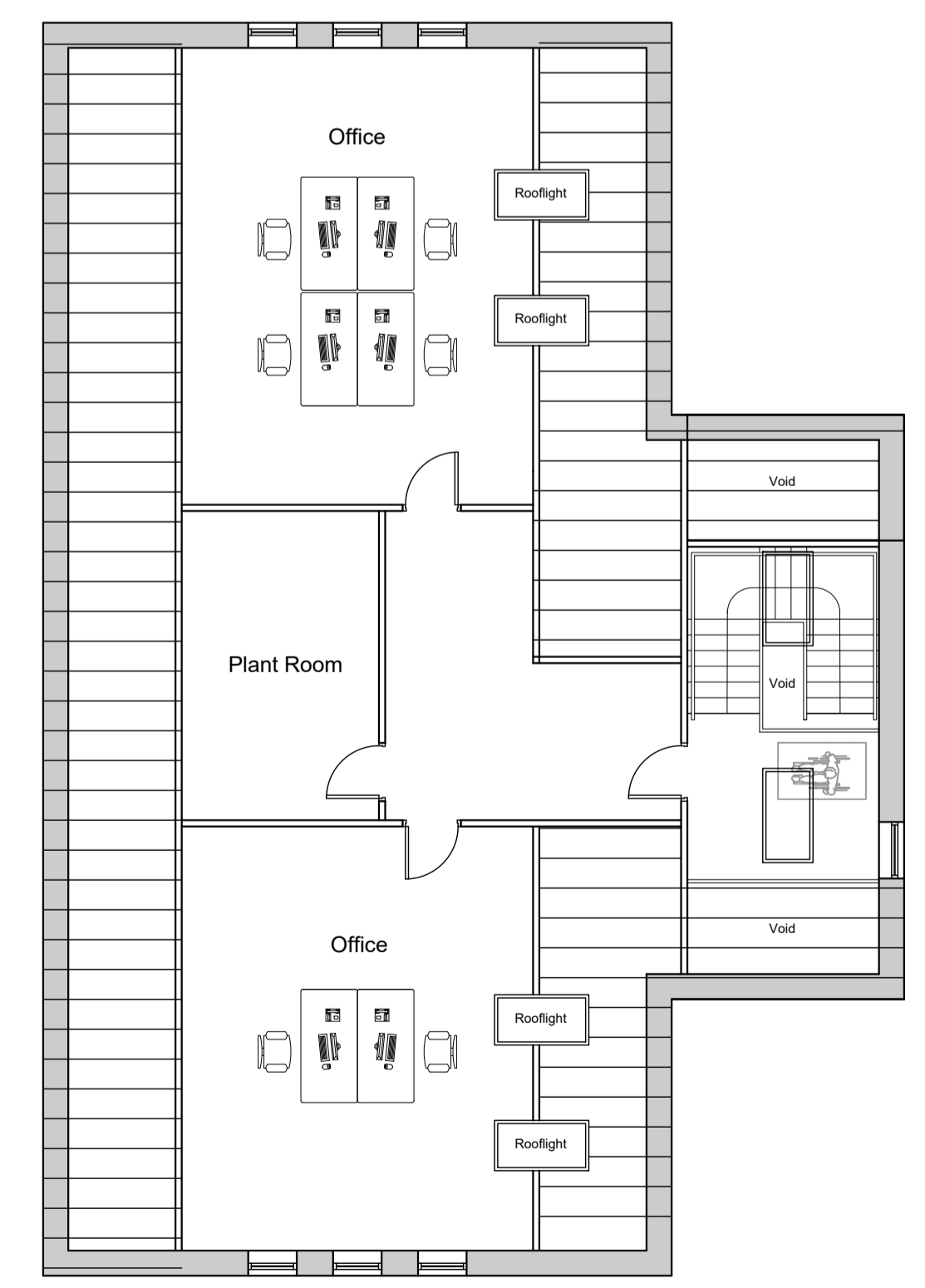

First Floor Plan  
1:100 Scale

Client  
**Mr Daniel McGowan**

Job Title  
Redevelopment of former Whalley Motor Services site into new offices at:  
18 Accrington Road  
Whalley  
BB7 9TD

Drawing Title  
**Proposed Floor Plans and Elevations**

Issued for Pre App

Scale: 1:100 @ A1 Date: June 2025 Drawn: Craig Harrison

**spa**  
SUNDERLAND PEACOCK & ASSOCIATES LTD.  
HARDENBERG, PINEWOOD ROAD, CLITHEROE,  
LANCASHIRE, BB7 3AG.  
T: 01204 423718 F: 01204 423728  
E: info@sunderlandpeacock.com  
www.sunderlandpeacock.com

**7261 -004**

## **Appendix C**

### EA Flood Data

# Flood risk assessment data



Location of site: 373471 / 436105 (shown as easting and northing coordinates)

Document created on: 10 September 2025

This information was previously known as a product 4.

Customer reference number: G1UUT6J8AVF6

Map showing the location that flood risk assessment data has been requested for.



## How to use this information

You can use this information as part of a flood risk assessment for a planning application. To do this, you should include it in the appendix of your flood risk assessment.

**We recommend that you work with a flood risk consultant to get your flood risk assessment.**

## Included in this document

In this document you'll find:

- how to find information about surface water and other sources of flooding
- information on the models used
- definitions for the terminology used throughout
- flood map for planning (rivers and the sea)
- past floods
- flood defences and attributes
- information to help you assess if there is a reduced flood risk from rivers and the sea because of defences
- modelled data
- information about strategic flood risk assessments
- information about this data
- information about flood risk activity permits
- help and advice

## Surface water and other sources of flooding

When using the surface water map on the [check your long term flood risk service](#) the following considerations apply:

- surface water extents are suitable for use in planning
- surface water climate change scenarios may help to inform risk assessments, but the available data fall short of what is required to assess planned development
- surface water depth information should not be used for planning purposes

To find out about other factors that might affect the flood risk of this location, you should also check:

- [reservoir flood risk](#)
- groundwater flood risk - you could use the [British Geological Survey groundwater flooding data](#), [groundwater: current status and flood risk](#) and the guide on [mining and groundwater constraints for development](#) - further information may be available from the lead local flood authority (LLFA)
- your local planning authority's SFRA, which includes future flood risk

Your Lead Local Flood Authority is Lancashire County.

For information about sewer flooding, contact the relevant water company for the area.

## **About the models used**

Model name: Whalley 2017

Scenario(s): Defended fluvial, defences removed fluvial, defended climate change fluvial, defences removed climate change fluvial

Date: 11 August 2017

This model contains the most relevant data for your area of interest.

## **Terminology used**

### **Annual exceedance probability (AEP)**

This refers to the probability of a flood event occurring in any year. The probability is expressed as a percentage. For example, a large flood which is calculated to have a 1% chance of occurring in any one year, is described as 1% AEP.

### **Metres above ordnance datum (mAOD)**

All flood levels are given in metres above ordnance datum which is defined as the mean sea level at Newlyn, Cornwall.

## Flood map for planning (rivers and the sea)

Your selected location is in flood zone 3.

Flood zone 3 shows the area at risk of flooding for an undefended flood event with a:

- 0.5% or greater probability of occurring in any year for flooding from the sea
- 1% or greater probability of occurring in any year for fluvial (river) flooding

Flood zone 2 shows the area at risk of flooding for an undefended flood event with:

- between a 0.1% and 0.5% probability of occurring in any year for flooding from the sea
- between a 0.1% and 1% probability of occurring in any year for fluvial (river) flooding

It's important to remember that the flood zones on this map:

- refer to the land at risk of flooding and do not refer to individual properties
- refer to the probability of river and sea flooding, ignoring the presence of defences
- do not take into account potential impacts of climate change







### Flood map for planning

Location (easting/northing)  
**373471/436105**

Scale  
**1:10,000**

Created  
**10 Sep 2025**

-  Selected area
-  Main river
-  Flood defence
-  Flood Zone 3
-  Flood Zone 2

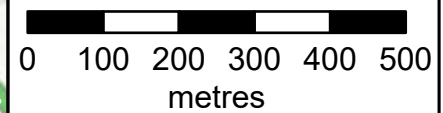
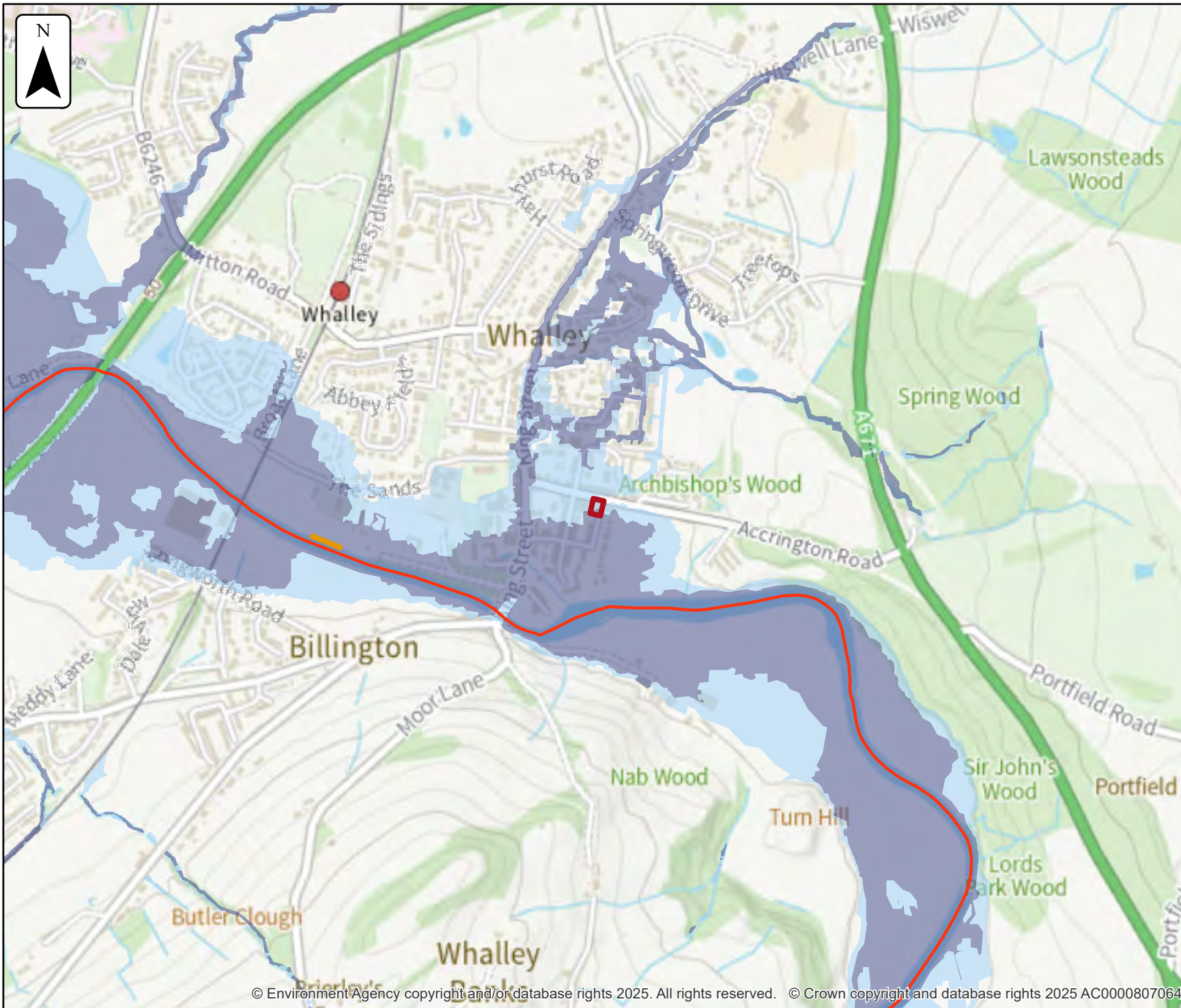

## Past floods

### Past flood events included in this document

The recorded flood outlines included in this document are for areas of land local to your site location that have been flooded by any of these sources:

- ephemeral water
- main rivers
- ordinary watercourses
- the sea
- unknown

### Data limitations

The outlines do not include flooding from:

- drainage where rainfall has led to surface water ponding or overland runoff
- artificial, water-bearing sewer, water supply and wastewater treatment pipelines

### Changes to flood defences

The defences (also known as assets) that were in place may also have changed. For example, assets may have been built more recently than the last recorded flood outline.

### What the recorded flood outlines dataset is

The recorded flood outlines are a geographical information system (GIS) data layer that show our verified records of areas that have flooded in the past from:

- rivers
- the sea
- groundwater
- surface water

[Download the complete recorded flood outlines dataset](#), which includes data quality flags for outlines recorded after April 2020. This indicates the confidence we have in an outline.

### Get flood information from other organisations

Contact Lancashire County Lead Local Flood Authority (LLFA) and your drainage board to get information about past flooding caused by surface water or drainage systems.



### Past floods

Location (easting/northing)  
**373471/436105**

Scale  
**1:10,000**

Created  
**10 Sep 2025**

-  Selected area
-  Main river
- Date of flood event
  -  December, 2024
  -  February, 2020
  -  December, 2015
  -  June, 2012
  -  October, 2000
  -  December, 1999

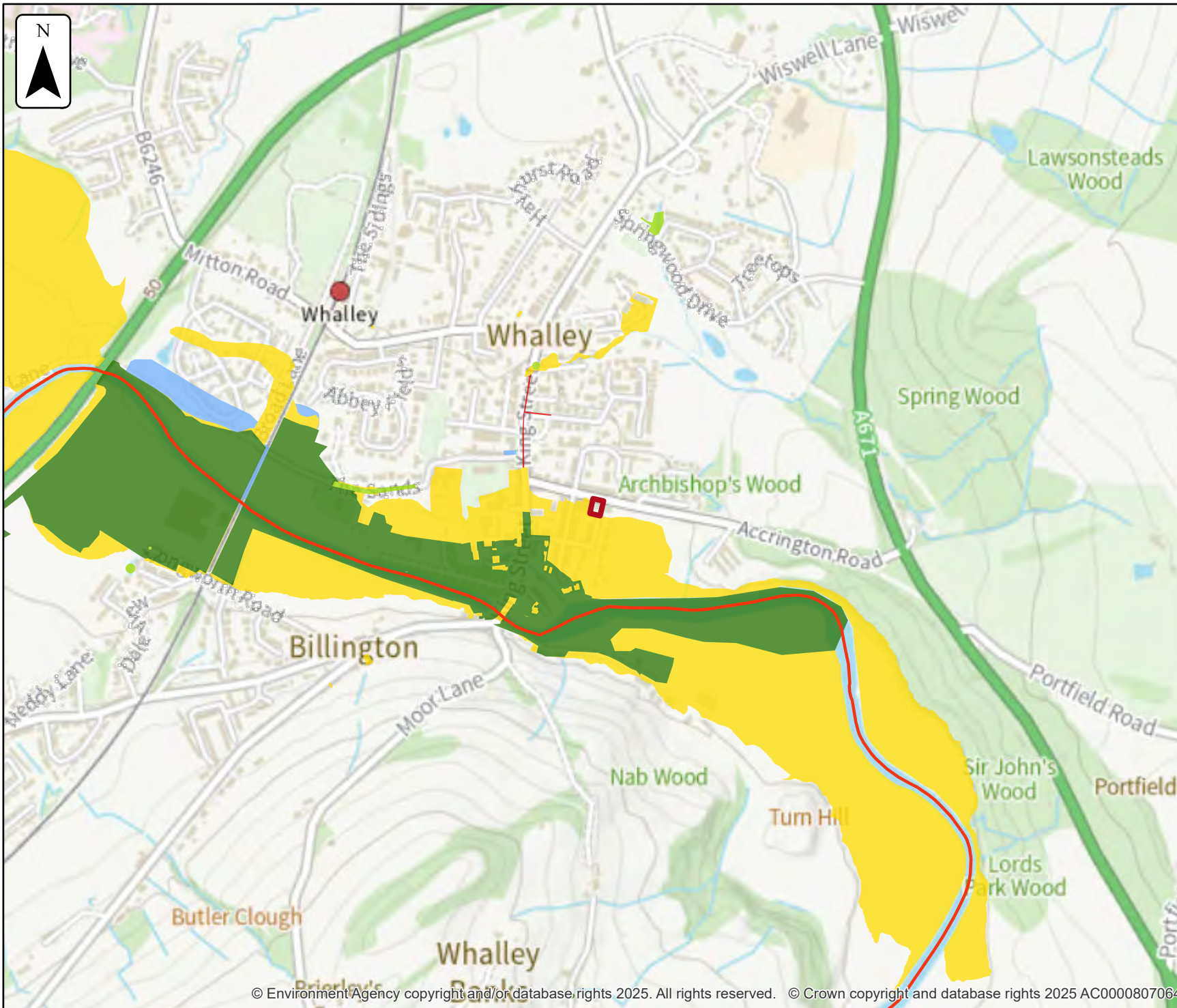

## Data on past flood events

Start date	End date	Source of flood	Cause of flood	Affects location
31 December 2024	1 January 2025	unknown	unknown	No
9 February 2020	10 February 2020	main river	overtopping of defences	No
26 December 2015	27 December 2015	main river	channel capacity exceeded (no raised defences)	Yes
22 June 2012	23 June 2012	unknown	local drainage/surface water	No
26 October 2000	27 October 2000	main river	channel capacity exceeded (no raised defences)	No
11 December 1999	12 December 1999	ordinary watercourse	obstruction/blockage - debris screen	No

## Flood defences and attributes

The flood defences map shows the location of the flood defences present.

The flood defences data table shows the type of defences, their condition and the standard of protection. It shows the height above sea level of the top of the flood defence (crest level). The height is in mAOD which is the metres above the mean sea level at Newlyn, Cornwall.

It's important to remember that flood defence data may not be updated on a regular basis. The information here is based on the best available data.

Use this information:

- to help you assess if there is a reduced flood risk for this location because of defences
- with any information in the modelled data section to find out the impact of defences on flood risk





### Flood defences

Location (easting/northing)  
**373471/436105**

Scale  
**1:5,000**

Created  
**10 Sep 2025**

-  Selected area
-  Main river
-  Flood defence

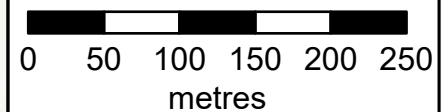
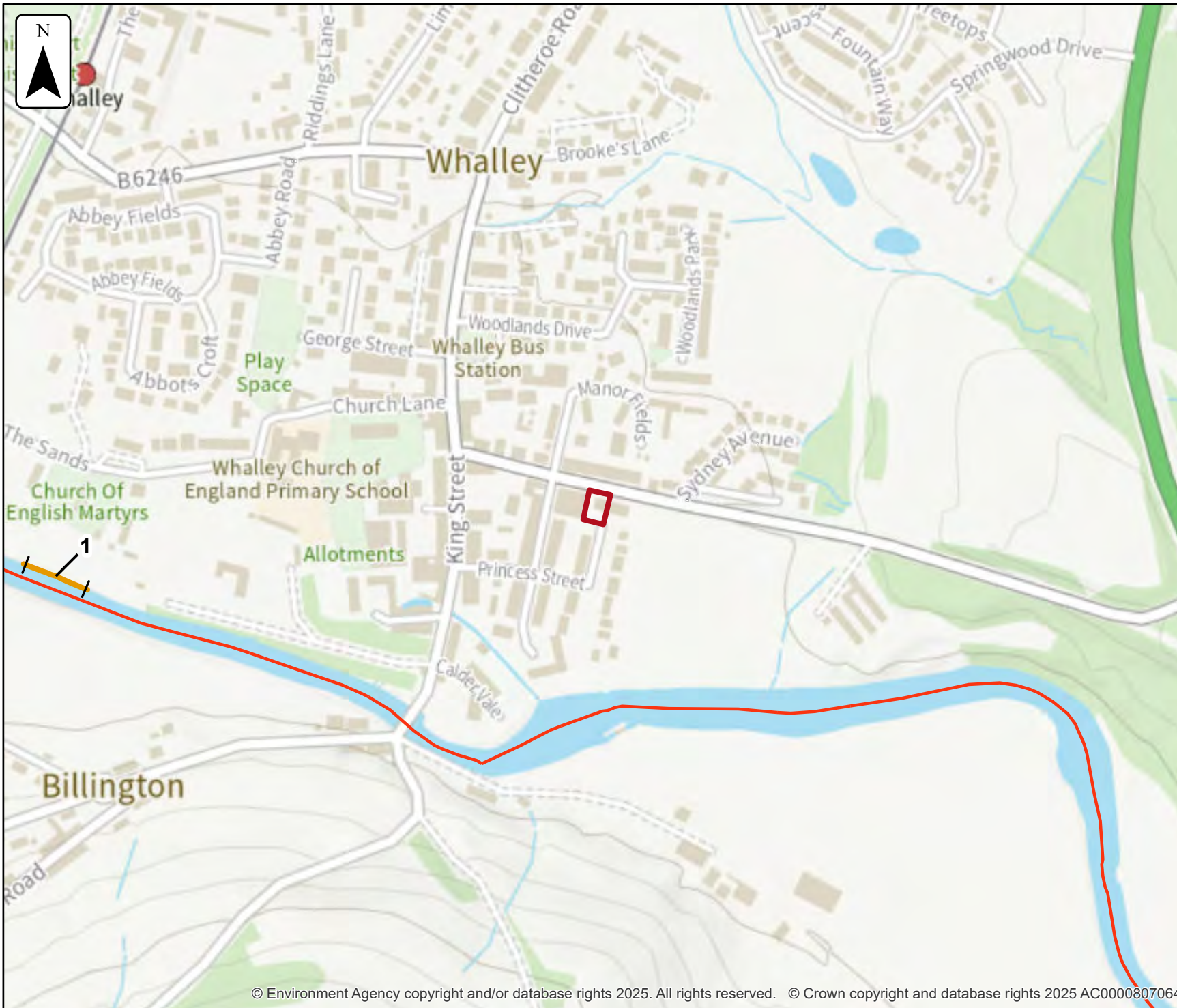

## Flood defences data

Label	Asset ID	Asset Type	Standard of protection (years)	Current condition	Downstream actual crest level (mAOD)	Upstream actual crest level (mAOD)	Effective crest level (mAOD)
1	64827	Embankment	5	Poor	43.90	43.90	43.90

Any blank cells show where a particular value has not been recorded for an asset.

## Modelled data

This section provides details of different scenarios we have modelled and includes the following (where available):

- outline maps showing the area at risk from flooding in different modelled scenarios
- modelled node point map(s) showing the points used to get the data to model the scenarios and table(s) providing details of the flood risk for different return periods
- map(s) showing the approximate water levels for the return period with the largest flood extent for a scenario and table(s) of sample points providing details of the flood risk for different return periods

## Climate change

The climate change data included in the models may not include the latest [flood risk assessment climate change allowances](#). Where the new allowances are not available you will need to consider this data and factor in the new allowances to demonstrate the development will be safe from flooding.

The Environment Agency will incorporate the new allowances into future modelling studies. For now, it's your responsibility to demonstrate that new developments will be safe in flood risk terms for their lifetime.

## Modelled scenarios

The following scenarios are included:

- Defended modelled fluvial: risk of flooding from rivers where there are flood defences
- Defences removed modelled fluvial: risk of flooding from rivers where flood defences have been removed
- Defended climate change modelled fluvial: risk of flooding from rivers where there are flood defences, including estimated impact of climate change
- Defences removed climate change modelled fluvial: risk of flooding from rivers where flood defences have been removed, including estimated impact of climate change



### Defences removed modelled fluvial extent

Location (easting/northing)  
**373471/436105**

Scale Created  
**1:10,000 10 Sep 2025**

Model name  
**Whalley 2017**

- Selected area
- Main river
- Modelled flood extent**
- 1.33% AEP
- 1% AEP
- 0.5% AEP
- 0.1% AEP

Flood extents may not be visible where they overlap other return periods

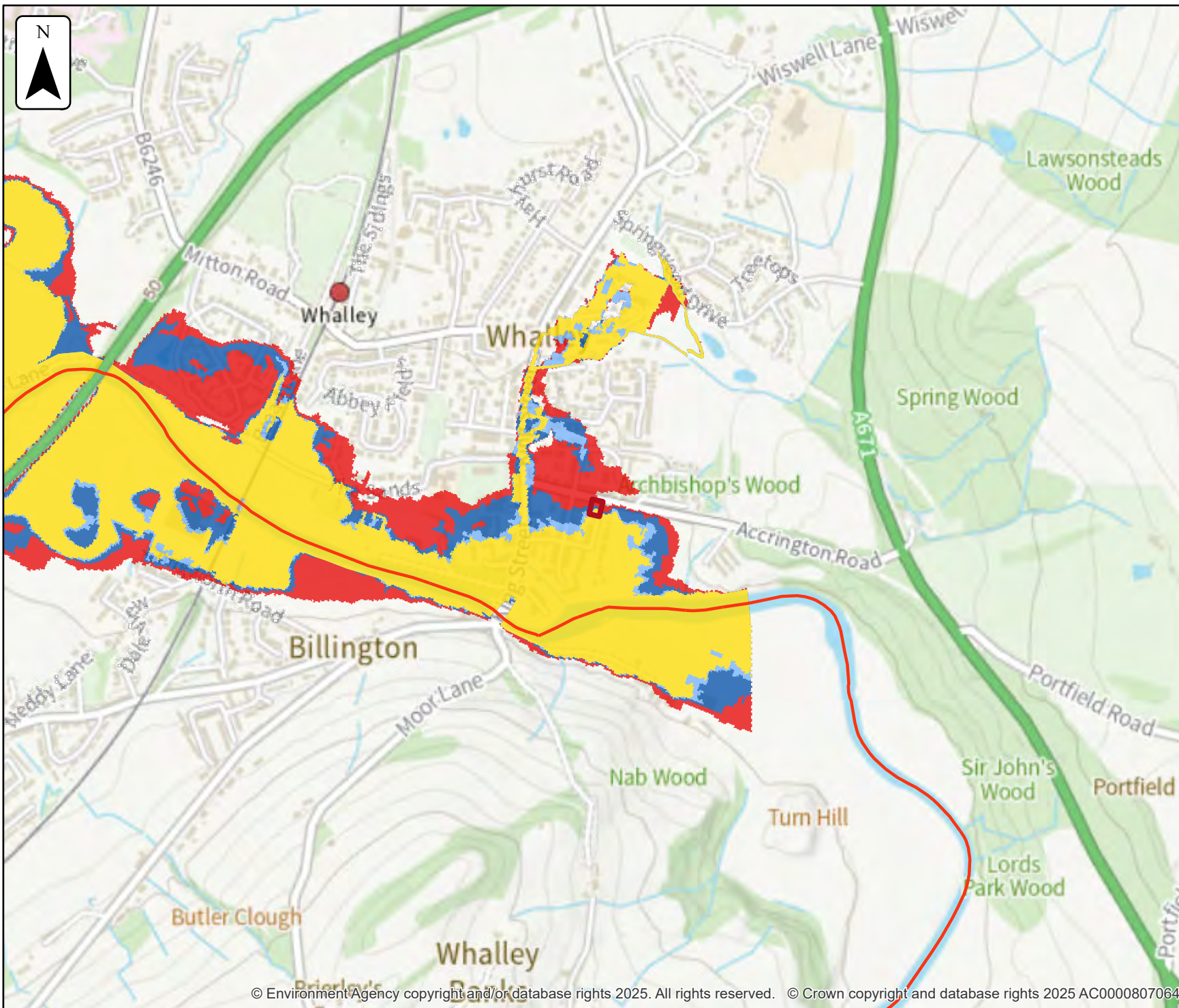
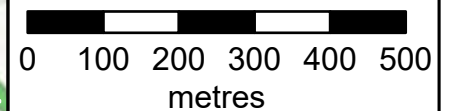





### Defences removed climate change modelled fluvial extent

Location (easting/northing)  
**373471/436105**

Scale Created  
**1:10,000 10 Sep 2025**

Model name  
**Whalley 2017**

-  Selected area
-  Main river
- Modelled flood extent
-  1% AEP (+15%)

Flood extents may not be visible where they overlap other return periods

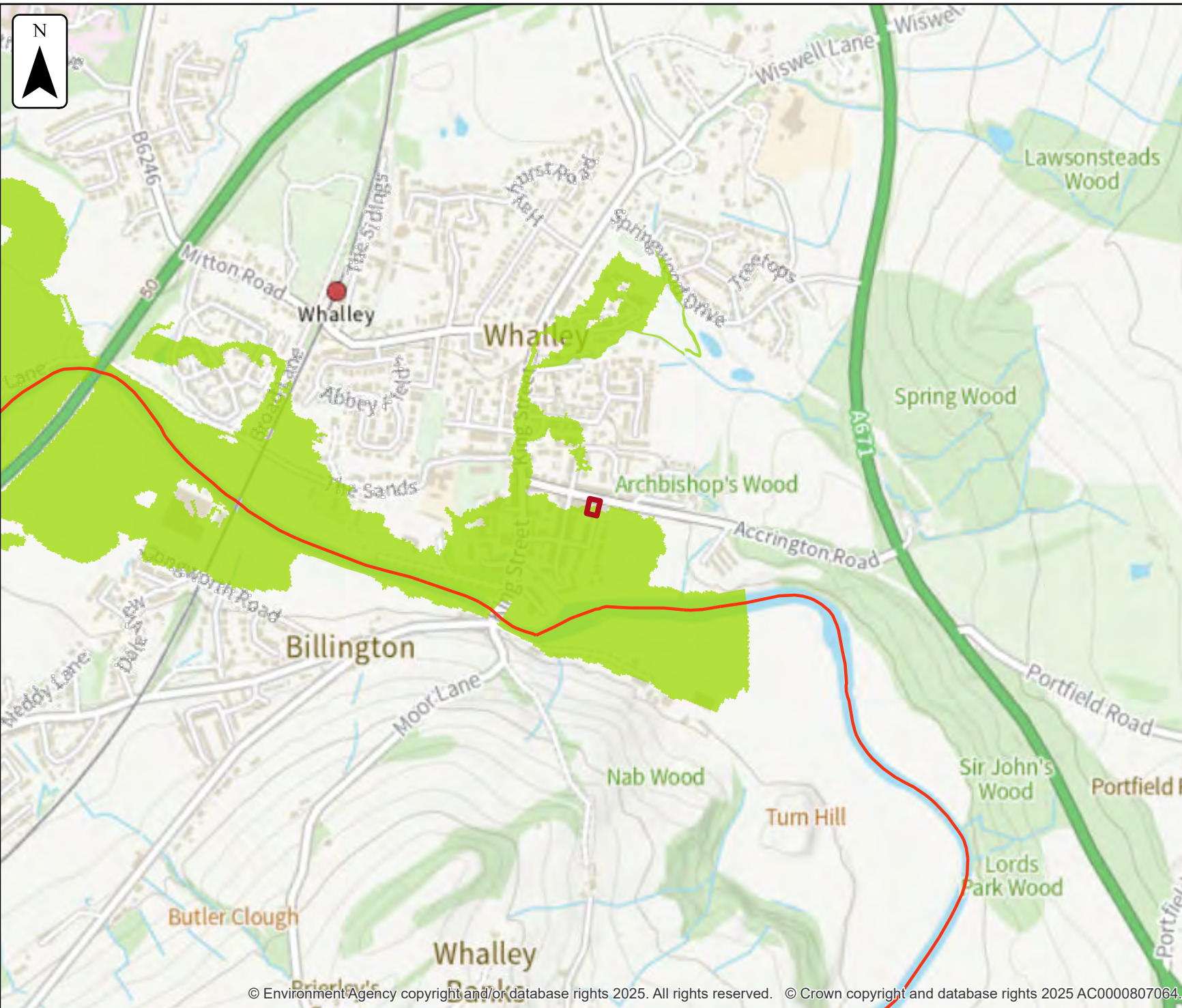
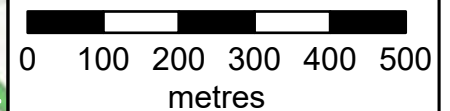



### Defended modelled fluvial extent

Location (easting/northing)  
**373471/436105**

Scale Created  
**1:10,000 10 Sep 2025**

Model name  
**Whalley 2017**

- Selected area
- Main river
- Modelled flood extent**
- 1.33% AEP
- 1% AEP
- 0.5% AEP
- 0.1% AEP

Flood extents may not be visible where they overlap other return periods

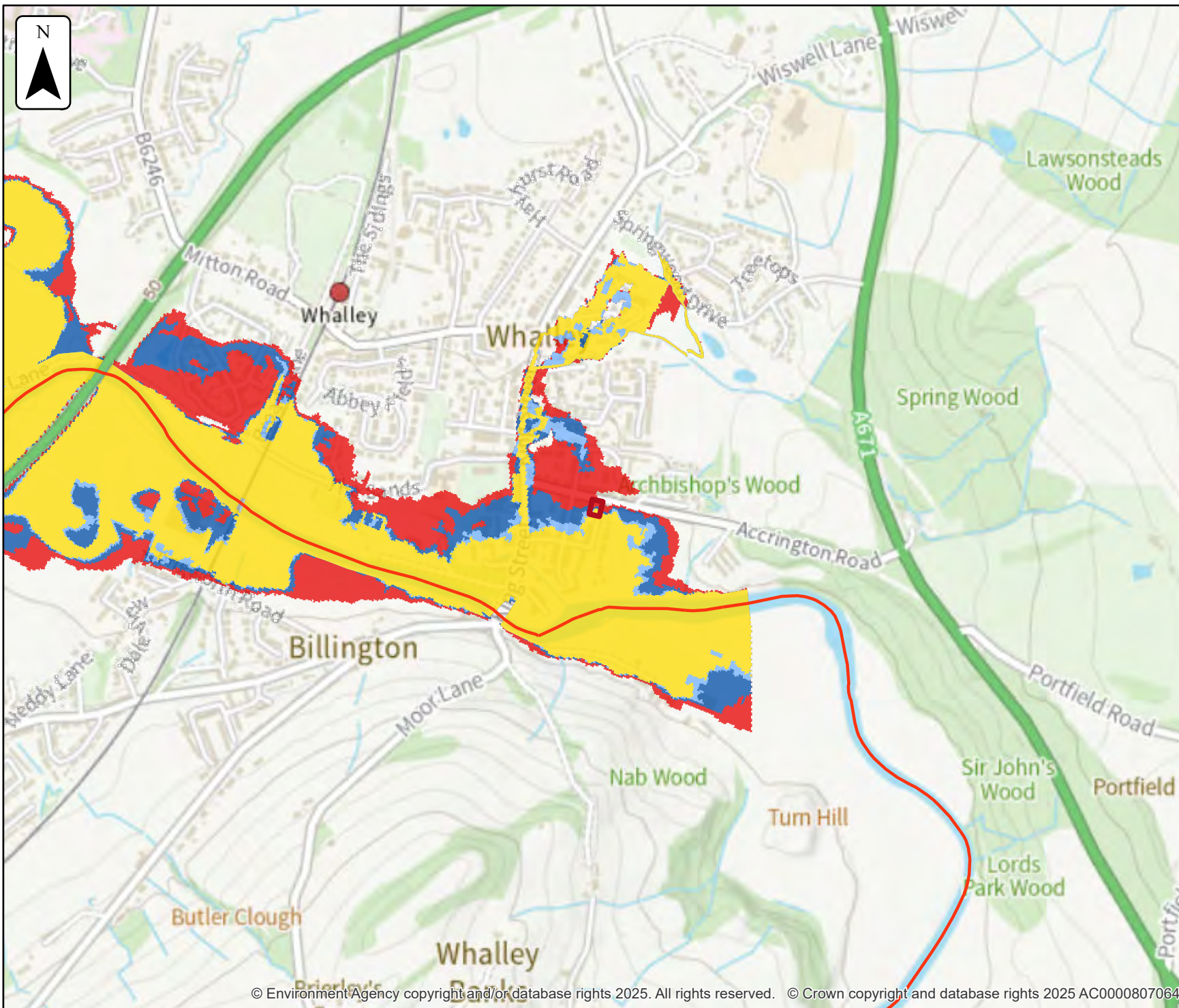
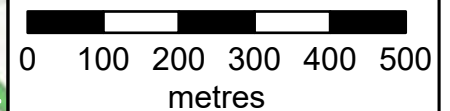





### Defended climate change modelled fluvial extent

Location (easting/northing)  
**373471/436105**

Scale Created  
**1:10,000 10 Sep 2025**

Model name  
**Whalley 2017**

-  Selected area
-  Main river
- Modelled flood extent
-  1% AEP (+15%)

Flood extents may not be visible where they overlap other return periods

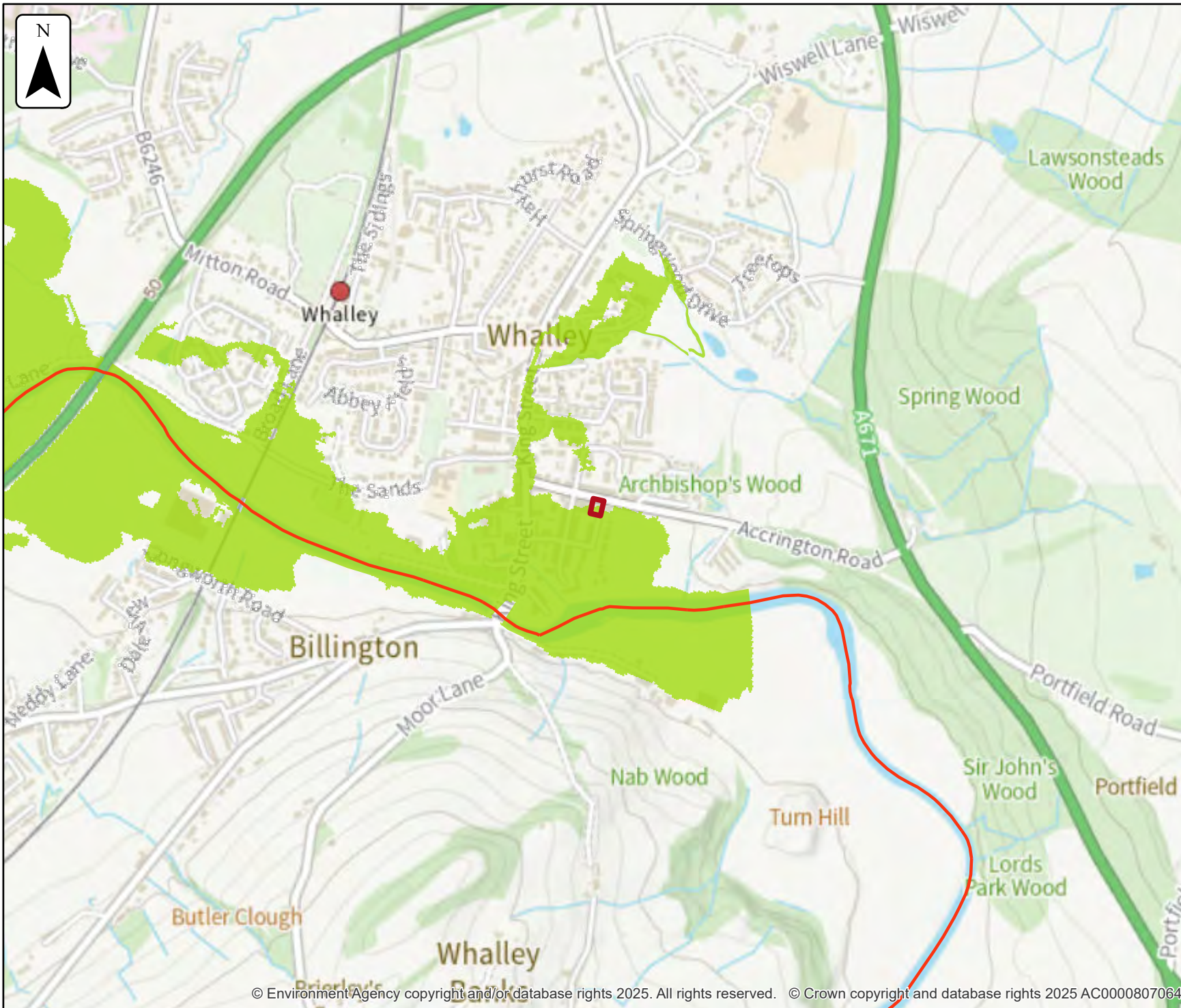
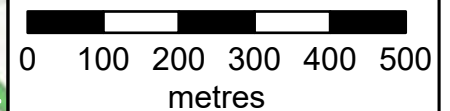





### Defences removed modelled fluvial node locations

Location (easting/northing)  
**373471/436105**

Scale Created  
**1:2,500 10 Sep 2025**

Model name  
**Whalley 2017**

-  Selected area
-  Modelled location
-  Main river

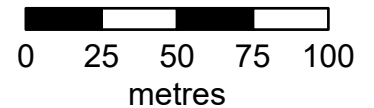

# Modelled node locations data

## Defences removed

Label	Modelled location ID	Easting	Northing	50% AEP	10% AEP	4% AEP	1.33% AEP	1% AEP	0.5% AEP	0.1% AEP
				Level	Level	Level	Level	Level	Level	Level
1	931604	373290	436010	43.42	44.87	44.60	45.15	45.29	45.74	46.73
2	931680	373311	436010	43.48	44.85	44.60	45.17	45.31	45.77	46.77
3	931632	373331	435999	43.51	45.63	44.86	45.30	45.42	45.88	46.92
4	931613	373334	436151					45.97	46.03	46.94
5	931614	373336	436037					45.40	45.87	46.90
6	931640	373350	435987	43.58	45.65	44.87	45.19	45.31	45.73	46.63
7	931675	373380	435956	43.72	45.67	44.92	45.52	45.65	46.10	47.17
8	931674	373401	435933	43.76	45.69	44.95	45.57	45.69	46.11	47.13
9	931635	373445	435903	44.91	45.98	45.45	45.89	46.01	46.41	47.51
10	931600	373506	435907	45.48	46.38	45.85	46.12	46.19	46.49	47.17

Data in this table comes from the Whalley 2017 model.  
 Level values are shown in mAOD, and flow values are shown in cubic metres per second.  
 Any blank cells show where a particular scenario has not been modelled for this location.

## Defences removed

Label	Modelled location ID	Easting	Northing	50% AEP	10% AEP	4% AEP	1.33% AEP	1% AEP	0.5% AEP	0.1% AEP
				Flow	Flow	Flow	Flow	Flow	Flow	Flow
1	931604	373290	436010	0.95	6.34	3.67	5.07	5.10	6.57	11.54
2	931680	373311	436010	0.95	6.34	3.60	3.71	3.71	3.73	3.75
3	931632	373331	435999	0.95	6.34	3.60	3.71	3.71	3.73	3.75
4	931613	373334	436151					0.03	0.03	0.03
5	931614	373336	436037					0.20	0.20	0.80
6	931640	373350	435987	0.95	6.34	3.86	12.77	14.65	20.80	40.49
7	931675	373380	435956	0.95	6.34	4.14	9.60	9.97	10.73	16.40
8	931674	373401	435933	0.95	6.34	3.89	10.43	11.56	14.71	27.14
9	931635	373445	435903	149.35	245.30	184.26	188.22	188.82	202.29	290.92
10	931600	373506	435907	149.34	245.32	184.76	197.05	203.73	245.20	474.92

Data in this table comes from the Whalley 2017 model.  
 Level values are shown in mAOD, and flow values are shown in cubic metres per second.  
 Any blank cells show where a particular scenario has not been modelled for this location.





### Defences removed climate change modelled fluvial node locations

Location (easting/northing)  
**373471/436105**

Scale Created  
**1:2,500 10 Sep 2025**

Model name  
**Whalley 2017**

-  Selected area
-  Modelled location
-  Main river

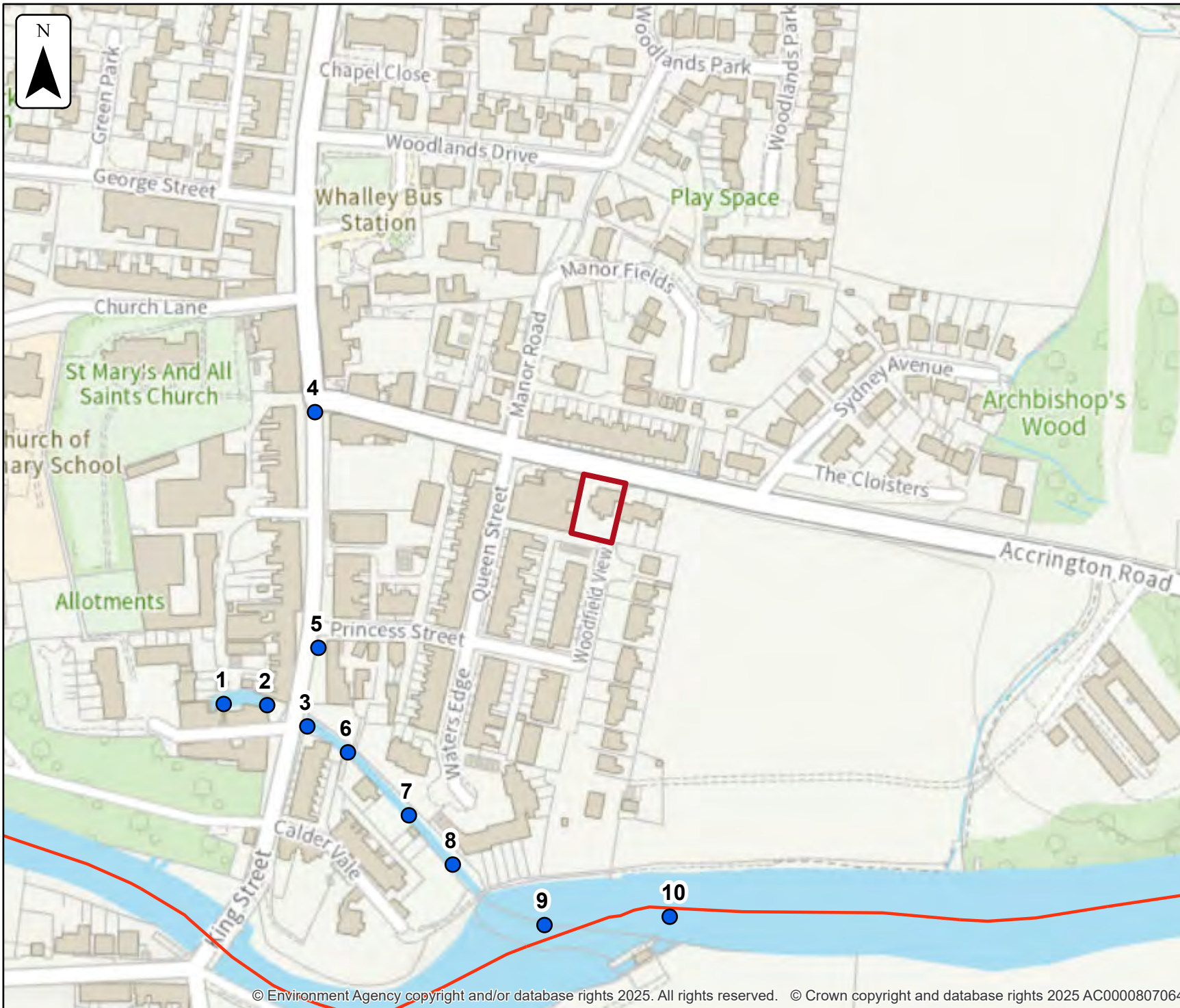

© Environment Agency copyright and/or database rights 2025. All rights reserved. © Crown copyright and database rights 2025 AC0000807064.

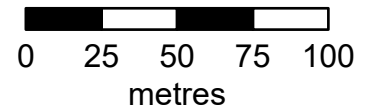

## Modelled node locations data

### Defences removed climate change

Label	Modelled location ID	Easting	Northing	1% AEP (+15%)	1% AEP (+15%)
				Level	Flow
1	931604	373290	436010	45.68	6.36
2	931680	373311	436010	45.71	3.73
3	931632	373331	435999	45.82	3.73
4	931613	373334	436151	46.02	0.03
5	931614	373336	436037	45.81	0.20
6	931640	373350	435987	45.67	19.90
7	931675	373380	435956	46.04	10.58
8	931674	373401	435933	46.05	14.21
9	931635	373445	435903	46.35	198.80
10	931600	373506	435907	46.44	237.41

Data in this table comes from the Whalley 2017 model.  
 Level values are shown in mAOD, and flow values are shown in cubic metres per second.  
 Any blank cells show where a particular scenario has not been modelled for this location.





### Defended modelled fluvial node locations

Location (easting/northing)  
**373471/436105**

Scale Created  
**1:2,500 10 Sep 2025**

Model name  
**Whalley 2017**

-  Selected area
-  Modelled location
-  Main river

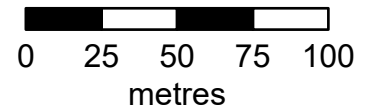
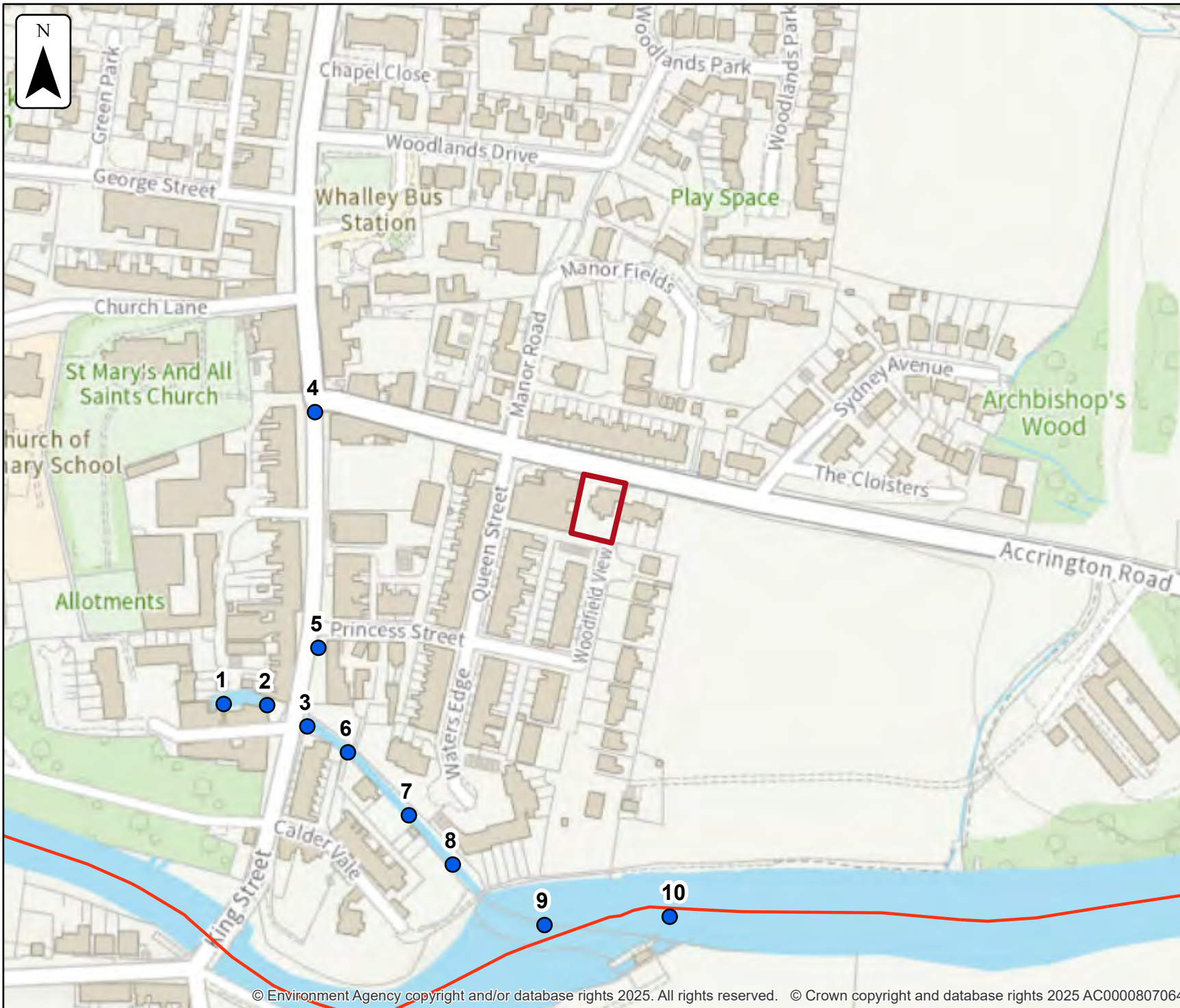

# Modelled node locations data

## Defended

Label	Modelled location ID	Easting	Northing	50% AEP	10% AEP	4% AEP	1.33% AEP	1% AEP	0.5% AEP	0.1% AEP
				Level	Level	Level	Level	Level	Level	Level
1	931604	373290	436010	43.42	44.07	44.60	45.15	45.29	45.74	46.73
2	931680	373311	436010	43.48	44.08	44.60	45.17	45.31	45.77	46.77
3	931632	373331	435999	43.51	44.11	44.86	45.29	45.42	45.88	46.92
4	931613	373334	436151					45.97	46.03	46.94
5	931614	373336	436037					45.40	45.87	46.90
6	931640	373350	435987	43.58	44.13	44.87	45.19	45.30	45.73	46.63
7	931675	373380	435956	43.72	44.17	44.92	45.52	45.65	46.10	47.17
8	931674	373401	435933	43.76	44.19	44.95	45.57	45.69	46.11	47.13
9	931635	373445	435903	44.91	45.07	45.45	45.89	46.01	46.41	47.51
10	931600	373506	435907	45.48	45.68	45.85	46.12	46.19	46.49	47.17

Data in this table comes from the Whalley 2017 model.  
 Level values are shown in mAOD, and flow values are shown in cubic metres per second.  
 Any blank cells show where a particular scenario has not been modelled for this location.

## Defended

Label	Modelled location ID	Easting	Northing	50% AEP	10% AEP	4% AEP	1.33% AEP	1% AEP	0.5% AEP	0.1% AEP
				Flow	Flow	Flow	Flow	Flow	Flow	Flow
1	931604	373290	436010	0.95	1.37	3.67	5.08	5.10	6.57	11.54
2	931680	373311	436010	0.95	1.37	3.61	3.71	3.72	3.73	3.75
3	931632	373331	435999	0.95	1.37	3.61	3.71	3.72	3.73	3.75
4	931613	373334	436151					0.03	0.03	0.03
5	931614	373336	436037					0.20	0.21	0.81
6	931640	373350	435987	0.95	1.37	3.88	12.76	14.63	20.77	40.49
7	931675	373380	435956	0.95	1.37	4.10	9.60	9.97	10.73	16.40
8	931674	373401	435933	0.95	1.37	3.88	10.43	11.56	14.70	27.14
9	931635	373445	435903	149.35	174.16	184.27	188.26	188.85	202.36	290.93
10	931600	373506	435907	149.34	174.17	184.73	197.04	203.74	245.08	474.91

Data in this table comes from the Whalley 2017 model.  
 Level values are shown in mAOD, and flow values are shown in cubic metres per second.  
 Any blank cells show where a particular scenario has not been modelled for this location.





### Defended climate change modelled fluvial node locations

Location (easting/northing)  
**373471/436105**

Scale Created  
**1:2,500 10 Sep 2025**

Model name  
**Whalley 2017**

-  Selected area
-  Modelled location
-  Main river



© Environment Agency copyright and/or database rights 2025. All rights reserved. © Crown copyright and database rights 2025 AC0000807064.

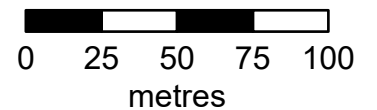

## Modelled node locations data

### Defended climate change

Label	Modelled location ID	Easting	Northing	1% AEP (+15%)	1% AEP (+15%)
				Level	Flow
1	931604	373290	436010	45.68	6.36
2	931680	373311	436010	45.70	3.73
3	931632	373331	435999	45.82	3.73
4	931613	373334	436151	46.02	0.03
5	931614	373336	436037	45.81	0.20
6	931640	373350	435987	45.67	19.88
7	931675	373380	435956	46.04	10.60
8	931674	373401	435933	46.05	14.20
9	931635	373445	435903	46.35	198.91
10	931600	373506	435907	46.44	237.22

Data in this table comes from the Whalley 2017 model.  
 Level values are shown in mAOD, and flow values are shown in cubic metres per second.  
 Any blank cells show where a particular scenario has not been modelled for this location.



# Sample point data

## Defences removed

Label	Easting	Northing	50% AEP	10% AEP	4% AEP	1.33% AEP	1% AEP	0.5% AEP	0.1% AEP
			Height	Height	Height	Height	Height	Height	Height
1	373460	436082	NoData	NoData	NoData	45.73	45.89	46.35	47.22
2	373468	436082	NoData	NoData	NoData	45.73	45.89	46.35	47.23
3	373476	436082	NoData	NoData	NoData	45.73	45.89	46.35	47.23
4	373484	436082	NoData	NoData	NoData	NoData	45.89	46.36	47.23
5	373452	436090	NoData	NoData	NoData	NoData	45.89	46.34	47.21
6	373460	436090	NoData	NoData	NoData	45.73	45.89	46.35	47.22
7	373468	436090	NoData	NoData	NoData	45.73	45.89	46.35	47.23
8	373476	436090	NoData	NoData	NoData	45.73	45.89	46.35	47.23
9	373484	436090	NoData	NoData	NoData	45.74	45.89	46.36	47.23
10	373452	436098	NoData	NoData	NoData	NoData	NoData	46.35	47.22
11	373460	436098	NoData	NoData	NoData	NoData	45.89	46.35	47.23
12	373468	436098	NoData	NoData	NoData	45.73	45.89	46.35	47.23

Label	Easting	Northing	50% AEP	10% AEP	4% AEP	1.33% AEP	1% AEP	0.5% AEP	0.1% AEP
			Height	Height	Height	Height	Height	Height	Height
13	373476	436098	NoData	NoData	NoData	45.73	45.89	46.35	47.23
14	373484	436098	NoData	NoData	NoData	NoData	NoData	NoData	47.23
15	373452	436106	NoData	NoData	NoData	NoData	NoData	46.35	47.21
16	373460	436106	NoData	NoData	NoData	NoData	NoData	46.35	47.23
17	373468	436106	NoData	NoData	NoData	NoData	NoData	46.35	47.23
18	373476	436106	NoData	NoData	NoData	NoData	NoData	NoData	47.23
19	373484	436106	NoData	NoData	NoData	NoData	NoData	NoData	47.23
20	373492	436106	NoData	NoData	NoData	NoData	NoData	NoData	47.24
21	373460	436114	NoData	NoData	NoData	NoData	NoData	NoData	47.19
22	373468	436114	NoData	NoData	NoData	NoData	NoData	NoData	47.19
23	373476	436114	NoData	NoData	NoData	NoData	NoData	NoData	47.22
24	373484	436114	NoData	NoData	NoData	NoData	NoData	NoData	NoData

Label	Easting	Northing	50% AEP	10% AEP	4% AEP	1.33% AEP	1% AEP	0.5% AEP	0.1% AEP
			Height	Height	Height	Height	Height	Height	Height
25	373492	436114	NoData	NoData	NoData	NoData	NoData	NoData	NoData
26	373460	436122	NoData	NoData	NoData	NoData	NoData	NoData	47.08
27	373468	436122	NoData	NoData	NoData	NoData	NoData	NoData	47.14
28	373476	436122	NoData	NoData	NoData	NoData	NoData	NoData	47.16
29	373484	436122	NoData	NoData	NoData	NoData	NoData	NoData	NoData
30	373492	436122	NoData	NoData	NoData	NoData	NoData	NoData	NoData
31	373460	436130	NoData	NoData	NoData	NoData	NoData	NoData	47.08
32	373468	436130	NoData	NoData	NoData	NoData	NoData	NoData	47.13
Max value in selected area:			NoData	NoData	NoData	45.73	45.89	46.35	47.23

Data in this table comes from the Whalley 2017 model. Height values are shown in mAOD, and depth values are shown in metres.

Any blank cells show where a particular scenario has not been modelled for this location.

Cells which contain text 'NoData' for a scenario show that return period has been modelled but there is no flood risk for that return period for that location.

'Max value in selected area' is the deepest depth or highest height at any location within your drawn boundary.

## Defences removed

Label	Easting	Northing	50% AEP	10% AEP	4% AEP	1.33% AEP	1% AEP	0.5% AEP	0.1% AEP
			Depth	Depth	Depth	Depth	Depth	Depth	Depth
1	373460	436082	NoData	NoData	NoData	0.19	0.34	0.80	1.67
2	373468	436082	NoData	NoData	NoData	0.16	0.31	0.78	1.65
3	373476	436082	NoData	NoData	NoData	0.21	0.37	0.83	1.71
4	373484	436082	NoData	NoData	NoData	NoData	0.12	0.58	1.46
5	373452	436090	NoData	NoData	NoData	NoData	0.10	0.55	1.42
6	373460	436090	NoData	NoData	NoData	0.01	0.17	0.63	1.50
7	373468	436090	NoData	NoData	NoData	0.10	0.26	0.72	1.60
8	373476	436090	NoData	NoData	NoData	0.13	0.29	0.75	1.63
9	373484	436090	NoData	NoData	NoData	0.01	0.15	0.62	1.49
10	373452	436098	NoData	NoData	NoData	NoData	NoData	0.43	1.30
11	373460	436098	NoData	NoData	NoData	NoData	0.10	0.56	1.43
12	373468	436098	NoData	NoData	NoData	0.16	0.32	0.78	1.66

Label	Easting	Northing	50% AEP	10% AEP	4% AEP	1.33% AEP	1% AEP	0.5% AEP	0.1% AEP
			Depth	Depth	Depth	Depth	Depth	Depth	Depth
13	373476	436098	NoData	NoData	NoData	0.14	0.30	0.76	1.64
14	373484	436098	NoData	NoData	NoData	NoData	NoData	NoData	1.16
15	373452	436106	NoData	NoData	NoData	NoData	NoData	0.13	0.99
16	373460	436106	NoData	NoData	NoData	NoData	NoData	0.15	1.02
17	373468	436106	NoData	NoData	NoData	NoData	NoData	0.16	0.95
18	373476	436106	NoData	NoData	NoData	NoData	NoData	NoData	1.03
19	373484	436106	NoData	NoData	NoData	NoData	NoData	NoData	0.37
20	373492	436106	NoData	NoData	NoData	NoData	NoData	NoData	0.19
21	373460	436114	NoData	NoData	NoData	NoData	NoData	NoData	0.34
22	373468	436114	NoData	NoData	NoData	NoData	NoData	NoData	0.19
23	373476	436114	NoData	NoData	NoData	NoData	NoData	NoData	0.00
24	373484	436114	NoData	NoData	NoData	NoData	NoData	NoData	NoData

Label	Easting	Northing	50% AEP	10% AEP	4% AEP	1.33% AEP	1% AEP	0.5% AEP	0.1% AEP
			Depth	Depth	Depth	Depth	Depth	Depth	Depth
25	373492	436114	NoData	NoData	NoData	NoData	NoData	NoData	NoData
26	373460	436122	NoData	NoData	NoData	NoData	NoData	NoData	0.06
27	373468	436122	NoData	NoData	NoData	NoData	NoData	NoData	0.09
28	373476	436122	NoData	NoData	NoData	NoData	NoData	NoData	0.00
29	373484	436122	NoData	NoData	NoData	NoData	NoData	NoData	NoData
30	373492	436122	NoData	NoData	NoData	NoData	NoData	NoData	NoData
31	373460	436130	NoData	NoData	NoData	NoData	NoData	NoData	0.06
32	373468	436130	NoData	NoData	NoData	NoData	NoData	NoData	0.06
Max value in selected area:			NoData	NoData	NoData	0.21	0.37	0.83	1.71

Data in this table comes from the Whalley 2017 model. Height values are shown in mAOD, and depth values are shown in metres.

Any blank cells show where a particular scenario has not been modelled for this location.

Cells which contain text 'NoData' for a scenario show that return period has been modelled but there is no flood risk for that return period for that location.

'Max value in selected area' is the deepest depth or highest height at any location within your drawn boundary.



### Defences removed climate change modelled fluvial extent and height

Location (easting/northing)  
**373471/436105**

Scale Created  
**1:500 10 Sep 2025**









Model name  
**Whalley 2017**

 Selected area

 Main river

Modelled 2D grid

Water level in mAOD

-  46 - 46.125
-  46.125 - 46.25
-  46.25 - 46.375
-  46.375 - 46.5
-  46.5 - 46.625
-  46.625 - 46.75
-  46.75 - 46.875
-  46.875 - 47.0
-  47.0 - 47.125

This map shows the  
1% AEP +15% height data

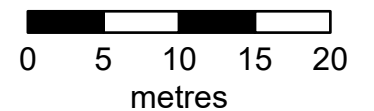

## Sample point data

### Defences removed climate change

Label	Easting	Northing	1% AEP (+15%)	1% AEP (+15%)
			Height	Depth
1	373460	436082	46.30	0.75
2	373468	436082	46.30	0.73
3	373476	436082	46.30	0.78
4	373484	436082	46.31	0.53
5	373452	436090	46.29	0.50
6	373460	436090	46.30	0.58
7	373468	436090	46.30	0.67
8	373476	436090	46.30	0.70
9	373484	436090	46.30	0.57
10	373452	436098	46.30	0.38
11	373460	436098	46.30	0.51
12	373468	436098	46.30	0.73

Label	Easting	Northing	1% AEP (+15%)	1% AEP (+15%)
			Height	Depth
13	373476	436098	46.30	0.71
14	373484	436098	NoData	NoData
15	373452	436106	46.30	0.08
16	373460	436106	46.30	0.10
17	373468	436106	NoData	NoData
18	373476	436106	NoData	NoData
19	373484	436106	NoData	NoData
20	373492	436106	NoData	NoData
21	373460	436114	NoData	NoData
22	373468	436114	NoData	NoData
23	373476	436114	NoData	NoData
24	373484	436114	NoData	NoData

Label	Easting	Northing	1% AEP (+15%)	1% AEP (+15%)
			Height	Depth
25	373492	436114	NoData	NoData
26	373460	436122	NoData	NoData
27	373468	436122	NoData	NoData
28	373476	436122	NoData	NoData
29	373484	436122	NoData	NoData
30	373492	436122	NoData	NoData
31	373460	436130	NoData	NoData
32	373468	436130	NoData	NoData
Max value in selected area:			46.30	0.78

Data in this table comes from the Whalley 2017 model. Height values are shown in mAOD, and depth values are shown in metres.

Any blank cells show where a particular scenario has not been modelled for this location.

Cells which contain text 'NoData' for a scenario show that return period has been modelled but there is no flood risk for that return period for that location.

'Max value in selected area' is the deepest depth or highest height at any location within your drawn boundary.



### Defended modelled fluvial extent and height

Location (easting/northing)  
**373471/436105**









Scale Created  
**1:500 10 Sep 2025**

Model name  
**Whalley 2017**

 Selected area

 Main river

Modelled 2D grid  
Water level in mAOD

-  0 - 6.0
-  6.0 - 12.0
-  12.0 - 18.0
-  18.0 - 24.0
-  24.0 - 30.0
-  30.0 - 36.0
-  36.0 - 42.0
-  42.0 - 48.0
-  48.0 - 54.0

This map shows the  
0.1% AEP height data

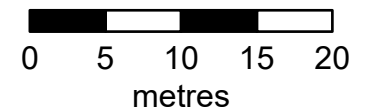

# Sample point data

## Defended

Label	Easting	Northing	50% AEP	10% AEP	4% AEP	1.33% AEP	1% AEP	0.5% AEP	0.1% AEP
			Height	Height	Height	Height	Height	Height	Height
1	373460	436082	NoData	NoData	NoData	45.73	45.89	46.35	47.22
2	373468	436082	NoData	NoData	NoData	45.73	45.89	46.35	47.23
3	373476	436082	NoData	NoData	NoData	45.73	45.89	46.35	47.23
4	373484	436082	NoData	NoData	NoData	NoData	45.89	46.36	47.23
5	373452	436090	NoData	NoData	NoData	NoData	45.89	46.34	47.21
6	373460	436090	NoData	NoData	NoData	45.73	45.89	46.35	47.22
7	373468	436090	NoData	NoData	NoData	45.73	45.89	46.35	47.23
8	373476	436090	NoData	NoData	NoData	45.73	45.89	46.35	47.23
9	373484	436090	NoData	NoData	NoData	45.74	45.89	46.35	47.23
10	373452	436098	NoData	NoData	NoData	NoData	NoData	46.35	47.22
11	373460	436098	NoData	NoData	NoData	NoData	45.89	46.35	47.23
12	373468	436098	NoData	NoData	NoData	45.73	45.89	46.35	47.23

Label	Easting	Northing	50% AEP	10% AEP	4% AEP	1.33% AEP	1% AEP	0.5% AEP	0.1% AEP
			Height	Height	Height	Height	Height	Height	Height
13	373476	436098	NoData	NoData	NoData	45.73	45.89	46.35	47.23
14	373484	436098	NoData	NoData	NoData	NoData	NoData	NoData	47.23
15	373452	436106	NoData	NoData	NoData	NoData	NoData	46.35	47.21
16	373460	436106	NoData	NoData	NoData	NoData	NoData	46.35	47.23
17	373468	436106	NoData	NoData	NoData	NoData	NoData	NoData	47.23
18	373476	436106	NoData	NoData	NoData	NoData	NoData	NoData	47.23
19	373484	436106	NoData	NoData	NoData	NoData	NoData	NoData	47.23
20	373492	436106	NoData	NoData	NoData	NoData	NoData	NoData	47.24
21	373460	436114	NoData	NoData	NoData	NoData	NoData	NoData	47.19
22	373468	436114	NoData	NoData	NoData	NoData	NoData	NoData	47.19
23	373476	436114	NoData	NoData	NoData	NoData	NoData	NoData	47.22
24	373484	436114	NoData	NoData	NoData	NoData	NoData	NoData	NoData

Label	Easting	Northing	50% AEP	10% AEP	4% AEP	1.33% AEP	1% AEP	0.5% AEP	0.1% AEP
			Height	Height	Height	Height	Height	Height	Height
25	373492	436114	NoData	NoData	NoData	NoData	NoData	NoData	NoData
26	373460	436122	NoData	NoData	NoData	NoData	NoData	NoData	47.08
27	373468	436122	NoData	NoData	NoData	NoData	NoData	NoData	47.14
28	373476	436122	NoData	NoData	NoData	NoData	NoData	NoData	47.16
29	373484	436122	NoData	NoData	NoData	NoData	NoData	NoData	NoData
30	373492	436122	NoData	NoData	NoData	NoData	NoData	NoData	NoData
31	373460	436130	NoData	NoData	NoData	NoData	NoData	NoData	47.08
32	373468	436130	NoData	NoData	NoData	NoData	NoData	NoData	47.13
Max value in selected area:			NoData	NoData	NoData	45.73	45.89	46.35	47.23

Data in this table comes from the Whalley 2017 model. Height values are shown in mAOD, and depth values are shown in metres.

Any blank cells show where a particular scenario has not been modelled for this location.

Cells which contain text 'NoData' for a scenario show that return period has been modelled but there is no flood risk for that return period for that location.

'Max value in selected area' is the deepest depth or highest height at any location within your drawn boundary.

## Defended

Label	Easting	Northing	50% AEP	10% AEP	4% AEP	1.33% AEP	1% AEP	0.5% AEP	0.1% AEP
			Depth	Depth	Depth	Depth	Depth	Depth	Depth
1	373460	436082	NoData	NoData	NoData	0.19	0.34	0.80	1.67
2	373468	436082	NoData	NoData	NoData	0.16	0.31	0.78	1.65
3	373476	436082	NoData	NoData	NoData	0.21	0.37	0.83	1.71
4	373484	436082	NoData	NoData	NoData	NoData	0.12	0.58	1.46
5	373452	436090	NoData	NoData	NoData	NoData	0.10	0.55	1.42
6	373460	436090	NoData	NoData	NoData	0.01	0.17	0.63	1.50
7	373468	436090	NoData	NoData	NoData	0.10	0.26	0.72	1.60
8	373476	436090	NoData	NoData	NoData	0.13	0.29	0.75	1.63
9	373484	436090	NoData	NoData	NoData	0.01	0.15	0.62	1.49
10	373452	436098	NoData	NoData	NoData	NoData	NoData	0.43	1.30
11	373460	436098	NoData	NoData	NoData	NoData	0.10	0.56	1.43
12	373468	436098	NoData	NoData	NoData	0.16	0.32	0.78	1.66

Label	Easting	Northing	50% AEP	10% AEP	4% AEP	1.33% AEP	1% AEP	0.5% AEP	0.1% AEP
			Depth	Depth	Depth	Depth	Depth	Depth	Depth
13	373476	436098	NoData	NoData	NoData	0.14	0.30	0.76	1.64
14	373484	436098	NoData	NoData	NoData	NoData	NoData	NoData	1.16
15	373452	436106	NoData	NoData	NoData	NoData	NoData	0.13	0.99
16	373460	436106	NoData	NoData	NoData	NoData	NoData	0.14	1.02
17	373468	436106	NoData	NoData	NoData	NoData	NoData	NoData	0.95
18	373476	436106	NoData	NoData	NoData	NoData	NoData	NoData	1.03
19	373484	436106	NoData	NoData	NoData	NoData	NoData	NoData	0.37
20	373492	436106	NoData	NoData	NoData	NoData	NoData	NoData	0.18
21	373460	436114	NoData	NoData	NoData	NoData	NoData	NoData	0.34
22	373468	436114	NoData	NoData	NoData	NoData	NoData	NoData	0.19
23	373476	436114	NoData	NoData	NoData	NoData	NoData	NoData	0.00
24	373484	436114	NoData	NoData	NoData	NoData	NoData	NoData	NoData

Label	Easting	Northing	50% AEP	10% AEP	4% AEP	1.33% AEP	1% AEP	0.5% AEP	0.1% AEP
			Depth	Depth	Depth	Depth	Depth	Depth	Depth
25	373492	436114	NoData	NoData	NoData	NoData	NoData	NoData	NoData
26	373460	436122	NoData	NoData	NoData	NoData	NoData	NoData	0.06
27	373468	436122	NoData	NoData	NoData	NoData	NoData	NoData	0.09
28	373476	436122	NoData	NoData	NoData	NoData	NoData	NoData	0.00
29	373484	436122	NoData	NoData	NoData	NoData	NoData	NoData	NoData
30	373492	436122	NoData	NoData	NoData	NoData	NoData	NoData	NoData
31	373460	436130	NoData	NoData	NoData	NoData	NoData	NoData	0.06
32	373468	436130	NoData	NoData	NoData	NoData	NoData	NoData	0.06
Max value in selected area:			NoData	NoData	NoData	0.21	0.37	0.83	1.71

Data in this table comes from the Whalley 2017 model. Height values are shown in mAOD, and depth values are shown in metres.

Any blank cells show where a particular scenario has not been modelled for this location.

Cells which contain text 'NoData' for a scenario show that return period has been modelled but there is no flood risk for that return period for that location.

'Max value in selected area' is the deepest depth or highest height at any location within your drawn boundary.



### Defended climate change modelled fluvial extent and height

Location (easting/northing)  
**373471/436105**









Scale Created  
**1:500 10 Sep 2025**

Model name  
**Whalley 2017**

 Selected area

 Main river

Modelled 2D grid  
Water level in mAOD

-  46 - 46.125
-  46.125 - 46.25
-  46.25 - 46.375
-  46.375 - 46.5
-  46.5 - 46.625
-  46.625 - 46.75
-  46.75 - 46.875
-  46.875 - 47.0
-  47.0 - 47.125

This map shows the  
1% AEP +15% height data

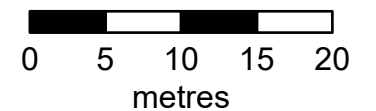

# Sample point data

## Defended climate change

Label	Easting	Northing	1% AEP (+15%)	1% AEP (+15%)
			Height	Depth
1	373460	436082	46.29	0.75
2	373468	436082	46.30	0.72
3	373476	436082	46.30	0.78
4	373484	436082	46.30	0.53
5	373452	436090	46.29	0.50
6	373460	436090	46.30	0.58
7	373468	436090	46.30	0.67
8	373476	436090	46.30	0.70
9	373484	436090	46.30	0.56
10	373452	436098	46.30	0.38
11	373460	436098	46.30	0.50
12	373468	436098	46.30	0.73

Label	Easting	Northing	1% AEP (+15%)	1% AEP (+15%)
			Height	Depth
13	373476	436098	46.30	0.71
14	373484	436098	NoData	NoData
15	373452	436106	46.30	0.08
16	373460	436106	46.30	0.10
17	373468	436106	NoData	NoData
18	373476	436106	NoData	NoData
19	373484	436106	NoData	NoData
20	373492	436106	NoData	NoData
21	373460	436114	NoData	NoData
22	373468	436114	NoData	NoData
23	373476	436114	NoData	NoData
24	373484	436114	NoData	NoData

Label	Easting	Northing	1% AEP (+15%)	1% AEP (+15%)
			Height	Depth
25	373492	436114	NoData	NoData
26	373460	436122	NoData	NoData
27	373468	436122	NoData	NoData
28	373476	436122	NoData	NoData
29	373484	436122	NoData	NoData
30	373492	436122	NoData	NoData
31	373460	436130	NoData	NoData
32	373468	436130	NoData	NoData
Max value in selected area:			46.30	0.78

Data in this table comes from the Whalley 2017 model. Height values are shown in mAOD, and depth values are shown in metres.

Any blank cells show where a particular scenario has not been modelled for this location.

Cells which contain text 'NoData' for a scenario show that return period has been modelled but there is no flood risk for that return period for that location.

'Max value in selected area' is the deepest depth or highest height at any location within your drawn boundary.

## Strategic flood risk assessments

We recommend that you check the relevant local authority's strategic flood risk assessment (SFRA) as part of your work to prepare a site specific flood risk assessment.

This should give you information about:

- the potential impacts of climate change in this catchment
- areas defined as functional floodplain
- flooding from other sources, such as surface water, ground water and reservoirs

Your Lead Local Flood Authority is Lancashire County.

## About this data

This data has been generated by strategic scale flood models and is not intended for use at the individual property scale. If you're intending to use this data as part of a flood risk assessment, please include an appropriate modelling tolerance as part of your assessment. The Environment Agency regularly updates its modelling. We recommend that you check the data provided is the most recent, before submitting your flood risk assessment.

## Flood risk activity permits

Under the Environmental Permitting (England and Wales) Regulations 2016 some developments may require an environmental permit for flood risk activities from the Environment Agency. This includes any permanent or temporary works that are in, over, under, or nearby a designated main river or flood defence structure.

[Find out more about flood risk activity permits](#)

## Help and advice

Contact the Cumbria and Lancashire Environment Agency team at [inforequests.cmlnc@environment-agency.gov.uk](mailto:inforequests.cmlnc@environment-agency.gov.uk) for:



- [more information about getting a product 5, 6, 7 or 8](#)
- general help and advice about the site you're requesting data for

## **Appendix C**

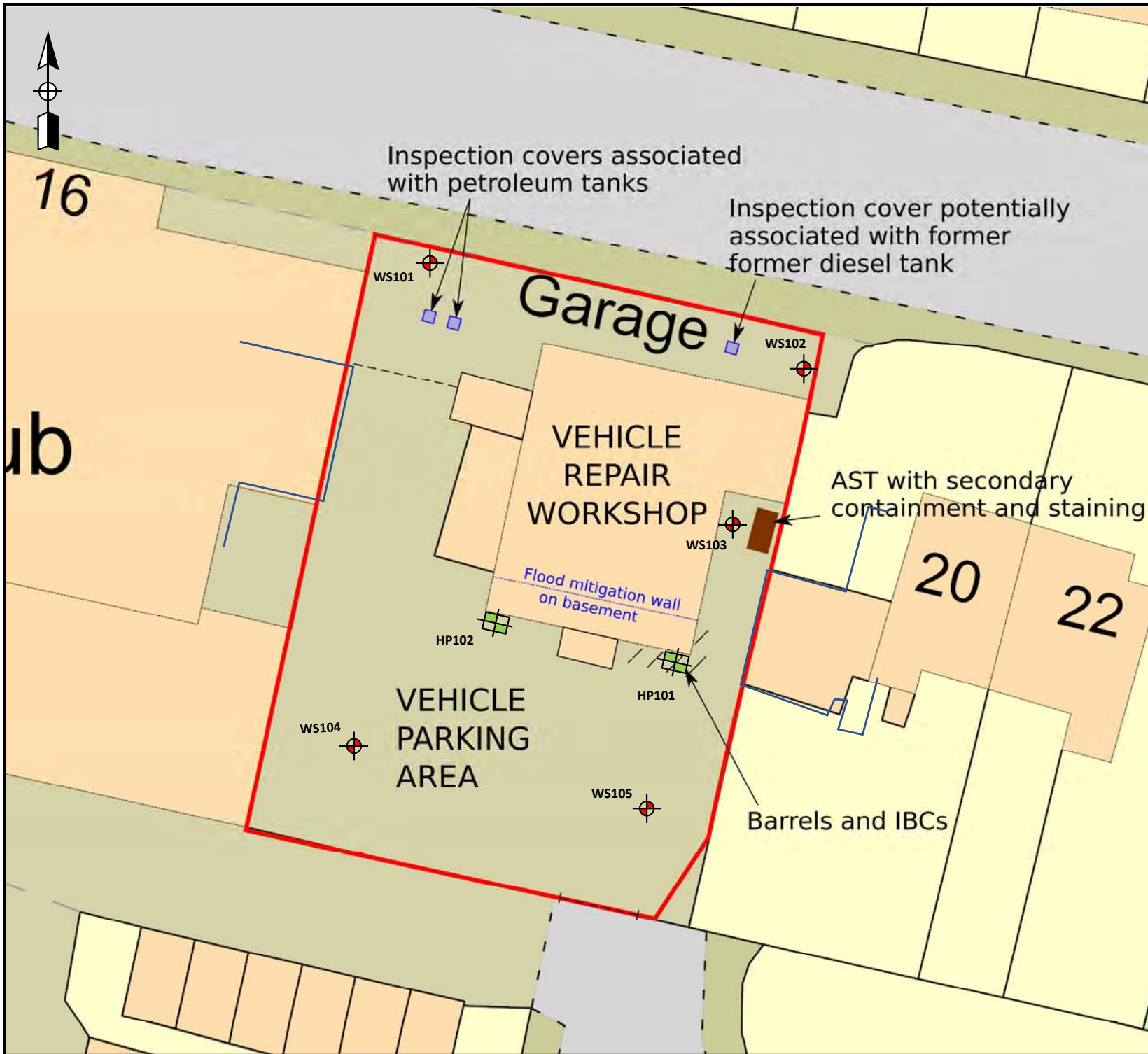
### Ground Investigation Extracts



**Key**

-  Windowless Sampler Borehole Location
-  Hand Dug Trial Pit Location
-  Approximate Site Boundary

**Notes:**

Not to Scale  
 This drawing should be read in conjunction with the associated ASL report.  
 All dimensions to be checked on site and not scaled on this drawing.

Drawing No.	<b>Figure 2</b>
Drawing Name	<b>Site Layout Plan</b>
Project Name	<b>Whalley Motors, 18 Accrington Road, Whalley</b>
Client Name	<b>Whalley Warm and Dry</b>
Project No.	<b>448-18-127</b>

**ASL**  
 Holly Farm Business Park  
 Honiley  
 Warwickshire  
 CV8 1NP

T: +44 (0)1926 485 508  
 E: info@aslenvironmental.co.uk  
 W: www.aslenvironmental.co.uk





**WS101**

Sheet 1 of 2

Project Name: **Land at Whalley Motors, 18 Accrington Road, Whalley.** Project No.: **448-18-127** Hole Type: **WLS**

Location: **Whalley Motors, 18 Accrington Road, Clitheroe** Co-ords: 373485.14 E 436114.62 N Level: 47.16m AOD Scale: 1:25





Client: **Whalley Warm and Dry** Start Dates: 29/01/2019 Finish: 29/01/2019 Logged By: SF

Sample and In Situ Testing					Depth (m)	Level (m)	Stratum Description	Legend	WS	Well
Depth (m)	Type	SPT	HPV (KPa)	PID (ppm)						
					0.20	46.96	MADE GROUND: Concrete hardstanding with occasional reinforcement bars.			
							MADE GROUND: Orange brown slightly sandy clayey angular fine to medium GRAVEL of brick, concrete, wood, clinker and rootlets.			
1.20	SPT (S)	N=0 (1,1/0,0,0,0)			1.20	45.96	Very loose orange brown mottled black slightly gravelly and locally gravelly very clayey SAND and locally slightly gravelly sandy clay. Gravel is subangular fine mudstone and sandstone. Slight hydrocarbon odour. (Alluvium)			
1.50	ES1			0.0						
1.80	ES2			0.0						
2.00 - 2.45 2.00	D3 SPT (S)	N=2 (1,1/0,1,0,1)			2.00	45.16	Very loose dark grey sandy very clayey angular to subrounded fine to coarse GRAVEL of mudstone, sandstone and quartzite and locally slightly sandy gravelly clay. Clay is organic. Moderate hydrocarbon and organic odour. (Alluvium)			
2.30	D4			45.3						
2.50	ES5			1.0						
2.80	D6			0.6						
3.00 - 3.45 3.00	D7 SPT (S)	N=3 (0,1/1,0,1,1)			3.20	43.96	Very loose black slightly gravelly clayey to very clayey SAND. Gravel is subangular to subrounded fine to coarse mudstone and sandstone. Slight hydrocarbon odour. (Alluvium)			
3.80	ES8			0.1						
4.00 - 4.45 4.00	D9 SPT (S)	N=13 (0,0/1,2,4,6)			4.00	43.16	Medium dense grey brown slightly gravelly slightly clayey SAND. Gravel is subangular to subrounded fine to medium and occasionally coarse mudstone, sandstone and quartzite. (Alluvium)			
4.70	ES10			4.1						
5.00 - 5.45	D11			2.0			Continued on Next Sheet			

**Remarks**  
Windowless sampling from ground level to completed depth. Groundwater encountered at 2.0m bgl. Installed with combined gas and groundwater standpipe on completion.

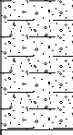
**Key**  
 D - Disturbed Sample  
 ES - Environmental Sample  
 B - Bulk Sample  
 U - Undisturbed Sample  
 SS - Surface Sample  
 VS - Validation Sample  
 W - Water Sample  
 N/R - No Recovery  
 HVP - Hand Vane Shear Test  
 W/S - Water Strike



		www.aslenvironmental.co.uk					Window Sample No. <b>WS101</b>					
Project Name: <b>Land at Whalley Motors, 18 Accrington Road, Whalley.</b>		Project No.: <b>448-18-127</b>			Sheet 2 of 2							
Location: <b>Whalley Motors, 18 Accrington Road, Clitheroe</b>		Co-ords: 373485.14 E 436114.62 N		Level: 47.16m AOD		Hole Type WLS						
Client: <b>Whalley Warm and Dry</b>		Start Dates: 29/01/2019		Finish 29/01/2019		Scale 1:25						
Logged By SF												
Sample and In Situ Testing							Depth (m)	Level (m)	Stratum Description	Legend	WS	Well
Depth (m)	Type	SPT	HPV (KPa)	PID (ppm)								
5.00	SPT (S)	N=29 (5,5/6,8,8,7)							Medium dense grey brown slightly gravelly slightly clayey SAND. Gravel is subangular to subrounded fine to medium and occasionally coarse mudstone, sandstone and quartzite. (Alluvium)			
					5.45	41.71	End of Borehole at 5.450m					
												
<b>Remarks</b> Windowless sampling from ground level to completed depth. Groundwater encountered at 2.0m bgl. Installed with combined gas and groundwater standpipe on completion.								<b>Key</b> D - Disturbed Sample ES - Environmental Sample B - Bulk Sample U - Undisturbed Sample SS - Surface Sample VS - Validation Sample W - Water Sample N/R - No Recovery HVP - Hand Vane Shear Test W/S - Water Strike				
												



Project Name: **Land at Whalley Motors, 18 Accrington Road, Whalley.** Project No.: **448-18-127** Hole Type: **WLS**

Location: **Whalley Motors, 18 Accrington Road, Clitheroe** Co-ords: 373465.78 E 436115.20 N Level: 46.88m AOD Scale: 1:25

Client: **Whalley Warm and Dry** Start Dates: 29/01/2019 Finish: 29/01/2019 Logged By: SF

Sample and In Situ Testing					Depth (m)	Level (m)	Stratum Description	Legend	WS	Well
Depth (m)	Type	SPT	HPV (KPa)	PID (ppm)						
0.20	ES1	N=0 (0,0/0,0,0,0)		0.2	0.10	46.78	MADE GROUND: Concrete hardstanding with occasional reinforcement bars. MADE GROUND: Black slightly sandy very clayey angular to subrounded fine to coarse GRAVEL of quartzite, sandstone and clinker. Moderate hydrocarbon odour.			
0.60	ES2				0.30	46.58				
1.20	SPT (S)	N=0 (0,0/0,0,0,0)		280.0	1.30	45.58	MADE GROUND: Soft black slightly sandy gravelly CLAY. Gravel is angular fine to medium clinker and slag. Strong hydrocarbon odour.			
1.50	ES3				1.90	44.98				
2.00 - 2.45	D4 SPT (S)				N=0 (0,0/0,0,0,0)		324.1	2.00	278.0	MADE GROUND: Dark brown slightly sandy clayey angular fine to coarse GRAVEL of concrete, brick, metal and foundry brick with occasional angular cobbles of brick and concrete.
2.10	D5	2.20	44.68							
2.70	ES6	N=0 (0,0/0,0,0,0)		311.1	2.70	44.68	Very loose dark grey locally mottled orange brown slightly gravelly clayey SAND with occasional pockets (<5mm) of organic matter and occasional rootlet tracts. Gravel is subrounded fine to medium mudstone and sandstone. (Alluvium)			
3.00 - 3.45	D7 SPT (S)				3.20	43.68				
3.70	ES8	N=6 (1,0/1,2,2,1)		152.0	3.70	43.68	Very loose dark grey slightly gravelly clayey to very clayey SAND with occasional fragments (<2cm) of organic matter and locally very sandy clay. Gravel is angular to subangular fine mudstone and sandstone. Moderate hydrocarbon odour. (Alluvium)			
4.00 - 4.45	D9 SPT (S)				4.30	42.58				
4.60	ES10	N=6 (1,0/1,2,2,1)		296.7	4.60	42.58	Grey gravelly clayey SAND. Gravel is subangular fine to medium mudstone. Moderate to slight hydrocarbon odour. (Alluvium)			
4.90	ES11				4.90	18.0				
5.00 - 5.45	D12			10.8						

Continued on Next Sheet

**Remarks**

Windowless sampling from ground level to completed depth. Groundwater encountered at 1.3m bgl. Installed with combined gas and groundwater standpipe on completion.

**Key**

- D - Disturbed Sample
- ES - Environmental Sample
- B - Bulk Sample
- U - Undisturbed Sample
- SS - Surface Sample
- VS - Validation Sample
- W - Water Sample
- N/R - No Recovery
- HVP - Hand Vane Shear Test
- WS - Water Strike





**WS102**

Sheet 2 of 2

Project Name: **Land at Whalley Motors, 18 Accrington Road, Whalley.** Project No.: **448-18-127** Hole Type: **WLS**

Location: **Whalley Motors, 18 Accrington Road, Clitheroe** Co-ords: **373465.78 E  
436115.20 N** Level: **46.88m AOD** Scale: **1:25**

Client: **Whalley Warm and Dry** Start Dates: **29/01/2019** Finish: **29/01/2019** Logged By: **SF**

Sample and In Situ Testing					Depth (m)	Level (m)	Stratum Description	Legend	WS	Well
Depth (m)	Type	SPT	HPV (KPa)	PID (ppm)						
5.00	SPT (S)	N=29 (5,5/6,8,8,7)					Medium dense.			
					5.45	41.43	End of Borehole at 5.450m			

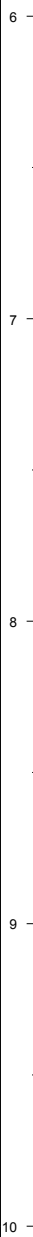

**Remarks**  
Windowless sampling from ground level to completed depth. Groundwater encountered at 1.3m bgl. Installed with combined gas and groundwater standpipe on completion.

**Key**  
 D - Disturbed Sample  
 ES - Environmental Sample  
 B - Bulk Sample  
 U - Undisturbed Sample  
 SS - Surface Sample  
 VS - Validation Sample  
 W - Water Sample  
 N/R - No Recovery  
 HVP - Hand Vane Shear Test  
 W/S - Water Strike



Project Name: <b>Land at Whalley Motors, 18 Accrington Road, Whalley.</b>		Project No.: <b>448-18-127</b>		Hole Type WLS	
Location: <b>Whalley Motors, 18 Accrington Road, Clitheroe</b>		Co-ords: 373480.21 E 436100.41 N	Level: 45.56m AOD	Scale 1:25	
Client: <b>Whalley Warm and Dry</b>		Start Dates: Finish 29/01/2019 29/01/2019		Logged By SF	

Sample and In Situ Testing					Depth (m)	Level (m)	Stratum Description	Legend	W/S	Well
Depth (m)	Type	SPT	HPV (KPa)	PID (ppm)						
0.20	ES1			3.3			MADE GROUND: Black slightly sandy clayey angular fine to medium GRAVEL of quartzite and mudstone. Hydrocarbon sheen and very strong hydrocarbon odour.			
0.50	ES2			14.2	0.40 45.16		MADE GROUND: Soft dark grey slightly sandy CLAY with occasional subangular fine gravel of clinker and mudstone and occasional pockets (<50mm) of organic matter. Slight hydrocarbon odour.			
0.80	ES3			5.5	0.60 44.96			Soft dark grey mottled orange brown CLAY with occasional root tracts. Slight hydrocarbon odour. (Alluvium)		
1.00 - 1.45	D4 SPT (S)	N=0 (0,0/0,0,0,0)		1.7	1.10 44.46		Soft dark grey slightly sandy becoming sandy with depth CLAY with occasional pockets (<10mm) of organic matter. (Alluvium)			
1.40	ES5			10.2	1.65 43.91		No recovery			
2.00	SPT (S)	N=0 (0,0/0,0,0,0)			2.00 43.56		Very loose dark grey clayey SAND and locally sandy clay. Moderate hydrocarbon odour and an oily sheen. (Alluvium) <i>Poor recovery.</i>			
2.80	ES6			54.6						
3.00 - 3.45	D7 SPT (S)	N=18 (5,4/4,3,6,5)		22.1	3.00 42.56		Medium dense dark grey brown slightly gravelly clayey SAND. Gravel is subrounded fine to medium quartzite, mudstone and sandstone. Slight hydrocarbon odour. (Alluvium)			
3.50	ES8			8.8						
4.00 - 4.45	D9 SPT (S)	N=9 (2,2/1,1,3,4)		4.1	4.00 41.56		Loose dark grey brown slightly gravelly very clayey SAND. Gravel is subrounded fine to medium quartzite, mudstone and sandstone. (Alluvium)			
4.40	ES10			7.5						
4.80	D11			1.0	4.60 40.96		Medium dense dark grey very sandy slightly clayey subrounded to rounded fine to coarse GRAVEL of quartzite, mudstone and sandstone. (Alluvium)			
5.00 - 5.45	D12			2.3			Continued on Next Sheet			

## Remarks

Windowless sampling from ground level to completed depth. Groundwater encountered at 1.1m bgl. Backfilled with arisings on completion.

## Key

D - Disturbed Sample  
ES - Environmental Sample  
B - Bulk Sample  
U - Undisturbed Sample  
SS - Surface Sample  
VS - Validation Sample  
W - Water Sample  
N/R - No Recovery  
HVP - Hand Vane Shear Test  
W/S - Water Strike







Project Name: **Land at Whalley Motors, 18 Accrington Road, Whalley.** Project No.: **448-18-127** Hole Type: **WLS**

Location: **Whalley Motors, 18 Accrington Road, Clitheroe** Co-ords: 373465.07 E 436095.48 N Level: 45.51m AOD Scale: 1:25

Client: **Whalley Warm and Dry** Start Dates: 29/01/2019 Finish: 29/01/2019 Logged By: SF

Sample and In Situ Testing					Depth (m)	Level (m)	Stratum Description	Legend	W/S	Well		
Depth (m)	Type	SPT	HPV (KPa)	PID (ppm)								
0.10	ES1	N=0 (0,0/0,0,0,0)			0.05	45.46	MADE GROUND: Tarmacadam. hardstanding					
0.20	ES2				0.15	45.36	MADE GROUND: Black slightly sandy slightly clayey angular fine to coarse GRAVEL of tarmacadam and igneous rock. (Subbase)					
0.40	ES3				0.30	45.21	MADE GROUND: Grey slightly sandy very clayey angular fine to medium GRAVEL of igneous rock and tarmacadam. Slight hydrocarbon odour.					
					0.50	45.01	MADE GROUND: Grey slightly sandy clayey angular fine to medium GRAVEL of mudstone.					
0.75	ES4				0.80	44.71	MADE GROUND: Firm dark grey slightly sandy CLAY with occasional subrounded fine to medium gravel of quartzite and rare angular cobbles of brick.					
0.90	ES5						Soft orange brown mottled grey CLAY with occasional root tracts. (Alluvium)					
1.00 - 1.45	D6											
1.00	SPT (S)						1.30				44.21	Soft dark grey slightly sandy CLAY with frequent rootlets and frequent pockets (<10mm) of organic matter. Slight hydrocarbon odour. (Alluvium)
1.60	ES7											Occasional fine to medium gravel sized wood fragments.
1.90	D8				N=1 (0,0/0,0,1,0)						1.80	43.71
2.00 - 2.45	D9											
2.00	SPT (S)											
2.60	ES10											
3.00 - 3.45	D11											
3.00	SPT (S)	N=20 (8,11/6,5,5,4)					Medium dense.					
3.50	D12											
3.90	D13						3.80	41.71	Dark grey silty SAND with occasional pockets (<20mm) of organic matter. (Alluvium)			
4.00 - 4.45	D14	N=8 (2,2/2,2,1,3)			4.00	41.51	Loose dark grey slightly gravelly slightly clayey to clayey SAND. Gravel is fine to medium subrounded to rounded mudstone, sandstone and quartzite. (Alluvium)					
4.00	SPT (S)											
4.50	D15											
4.90	D16						4.80	40.71	Soft to firm dark grey slightly sandy SILT. (Alluvium)			

Continued on Next Sheet

**Remarks**

Windowless sampling from ground level to completed depth. Groundwater encountered at 0.9m bgl. Installed with combined gas and groundwater standpipe on completion.

**Key**

- D - Disturbed Sample
- ES - Environmental Sample
- B - Bulk Sample
- U - Undisturbed Sample
- SS - Surface Sample
- VS - Validation Sample
- W - Water Sample
- N/R - No Recovery
- HVP - Hand Vane Shear Test
- W/S - Water Strike





**WS104**

Sheet 2 of 2

Project Name: **Land at Whalley Motors, 18 Accrington Road, Whalley.** Project No.: **448-18-127** Hole Type: **WLS**

Location: **Whalley Motors, 18 Accrington Road, Clitheroe** Co-ords: **373465.07 E  
436095.48 N** Level: **45.51m AOD** Scale: **1:25**

Client: **Whalley Warm and Dry** Start Dates: **29/01/2019** Finish: **29/01/2019** Logged By: **SF**

Sample and In Situ Testing					Depth (m)	Level (m)	Stratum Description	Legend	WS	Well
Depth (m)	Type	SPT	HPV (KPa)	PID (ppm)						
5.00	SPT (S)	N=15 (3,4/4,4,4,3)					Soft to firm dark grey slightly sandy SILT. (Alluvium)			
					5.45	40.06	End of Borehole at 5.450m			

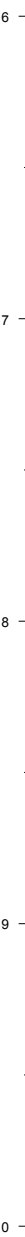

**Remarks**  
 Windowless sampling from ground level to completed depth. Groundwater encountered at 0.9m bgl. Installed with combined gas and groundwater standpipe on completion.

**Key**  
 D - Disturbed Sample  
 ES - Environmental Sample  
 B - Bulk Sample  
 U - Undisturbed Sample  
 SS - Surface Sample  
 VS - Validation Sample  
 W - Water Sample  
 N/R - No Recovery  
 HVP - Hand Vane Shear Test  
 W/S - Water Strike





Project Name: **Land at Whalley Motors, 18 Accrington Road, Whalley.** Project No.: **448-18-127** Hole Type: **WLS**

Location: **Whalley Motors, 18 Accrington Road, Clitheroe** Co-ords: 373477.27 E 436092.66 N Level: 45.51m AOD Scale: 1:25

Client: **Whalley Warm and Dry** Start Dates: 29/01/2019 Finish: 29/01/2019 Logged By: SF

Sample and In Situ Testing					Depth (m)	Level (m)	Stratum Description	Legend	W/S	Well
Depth (m)	Type	SPT	HPV (KPa)	PID (ppm)						
0.10	ES1			0.1	0.05	45.46	MADE GROUND: Tarmacadam hardstanding.			
					0.20	45.31	MADE GROUND: Black sandy slightly clayey angular fine to coarse GRAVEL of tarmacadam, clinker, slag and brick. Slight hydrocarbon odour. (Subbase)			
0.30	ES2			0.1	0.40	45.11	MADE GROUND: Black gravelly clayey SAND. Gravel is subangular fine to medium charcoal, quartzite, wood, brick and tile. Slight hydrocarbon odour.			
0.50	ES3			0.1	0.60	44.91	MADE GROUND: Firm black mottled grey slightly sandy slightly gravelly CLAY. Gravel is subangular fine to coarse quartzite and brick. Slight hydrocarbon odour.			
0.80	D4			0.1	0.90	44.61	MADE GROUND: Red brown sandy slightly clayey angular to subangular fine to coarse GRAVEL of brick.			
0.95 - 1.00 - 1.45	D5 D6 SPT (S)	N=2 (1,0/1,0,1,0)		0.1			MADE GROUND: Very loose light grey gravelly slightly clayey SAND. Gravel is angular fine to coarse concrete and brick.			
1.40	D7			0.2	1.40	44.11	Medium dense becoming dense with depth grey brown slightly gravelly and locally gravelly clayey SAND. Gravel is subrounded to rounded fine to medium and occasionally coarse mudstone, sandstone and occasional chalk and coal. (Alluvium)			
1.80	D8			0.1			Slight hydrocarbon odour.			
2.00 - 2.45 2.00	D9 SPT (S)	N=12 (0,1/1,3,4,4)		0.0			Poor recovery.			
2.80	D10			1.2						
3.00 - 3.45 3.00	D11 SPT (S)	N=42 (5,7/11,11,10,10)		0.5						
					3.50	42.01	Medium dense grey brown very sandy clayey subangular to rounded fine to coarse GRAVEL of mudstone, sandstone, quartzite and occasional coal. (Alluvium)			
3.80	D12			0.1						
4.00 - 4.45 4.00	D13 SPT (S)	N=39 (25 for 125mm/10,14,9,6)		0.2						
4.80	D14			0.2						
5.00 - 5.45	D15			0.1						

Continued on Next Sheet





**Remarks**

Windowless sampling from ground level to completed depth. Groundwater encountered at 0.6m bgl. Installed with combined gas and groundwater standpipe on completion.

**Key**

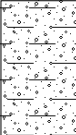
- D - Disturbed Sample
- ES - Environmental Sample
- B - Bulk Sample
- U - Undisturbed Sample
- SS - Surface Sample
- VS - Validation Sample
- W - Water Sample
- N/R - No Recovery
- HVP - Hand Vane Shear Test
- W/S - Water Strike



 www.aslenvironmental.co.uk							Window Sample No. <b>WS105</b> Sheet 2 of 2					
Project Name: <b>Land at Whalley Motors, 18 Accrington Road, Whalley.</b>					Project No.: <b>448-18-127</b>		Hole Type WLS					
Location: <b>Whalley Motors, 18 Accrington Road, Clitheroe</b>					Co-ords: 373477.27 E 436092.66 N	Level: 45.51m AOD	Scale 1:25					
Client: <b>Whalley Warm and Dry</b>					Start 29/01/2019	Dates: Finish 29/01/2019	Logged By SF					
Sample and In Situ Testing							Depth (m)	Level (m)	Stratum Description	Legend	WS	Well
Depth (m)	Type	SPT	HPV (KPa)	PID (ppm)								
5.00	SPT (S)	N=11 (3,4/2,3,3,3)						Medium dense grey brown very sandy clayey subangular to rounded fine to coarse GRAVEL of mudstone, sandstone, quartzite and occasional coal. (Alluvium)				
					5.45	40.06		End of Borehole at 5.450m				
												
<b>Remarks</b> Windowless sampling from ground level to completed depth. Groundwater encountered at 0.6m bgl. Installed with combined gas and groundwater standpipe on completion.							<b>Key</b> D - Disturbed Sample ES - Environmental Sample B - Bulk Sample U - Undisturbed Sample SS - Surface Sample VS - Validation Sample W - Water Sample N/R - No Recovery HVP - Hand Vane Shear Test W/S - Water Strike					

## **Appendix E**

PSA Design Drawing

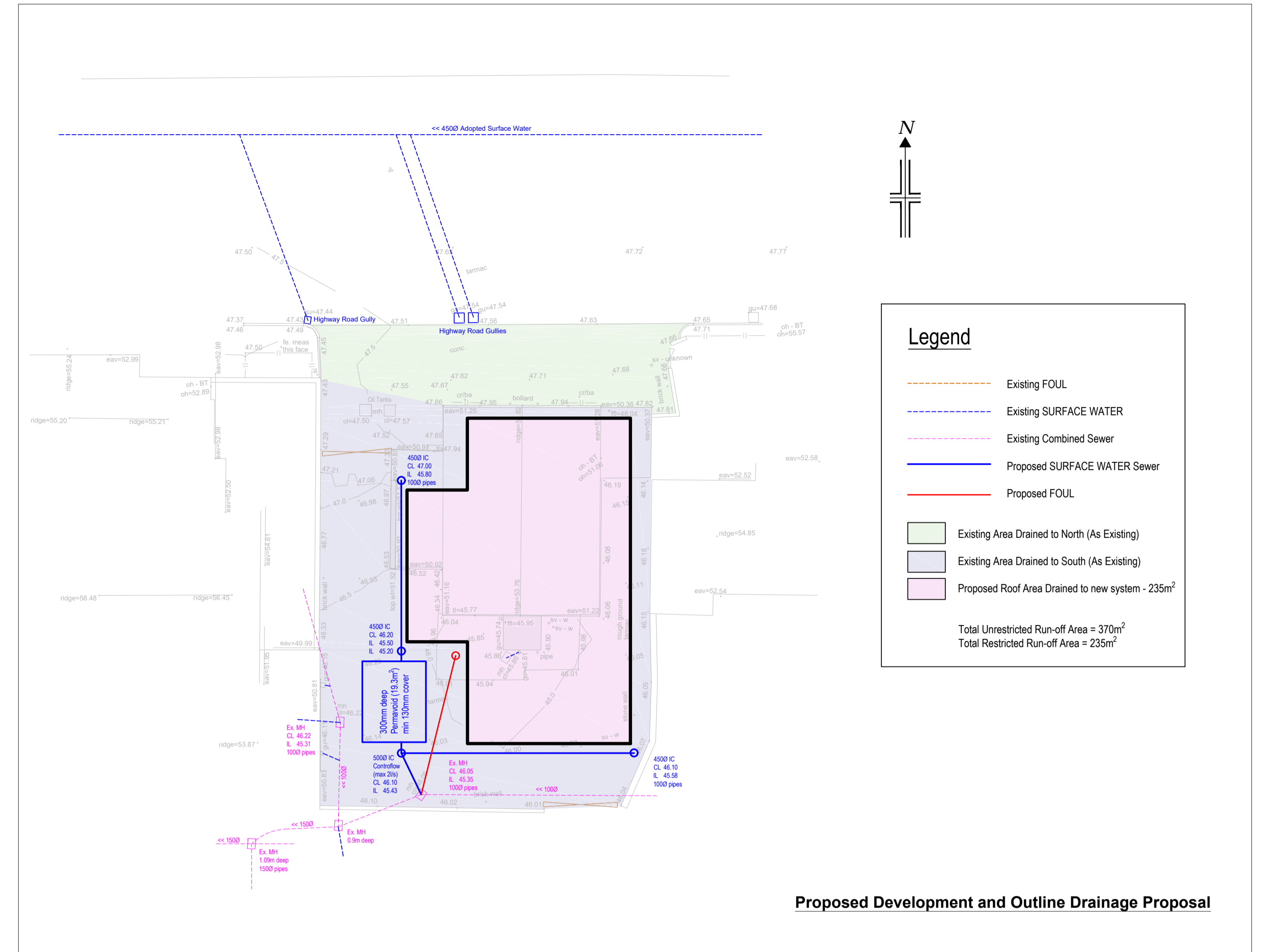
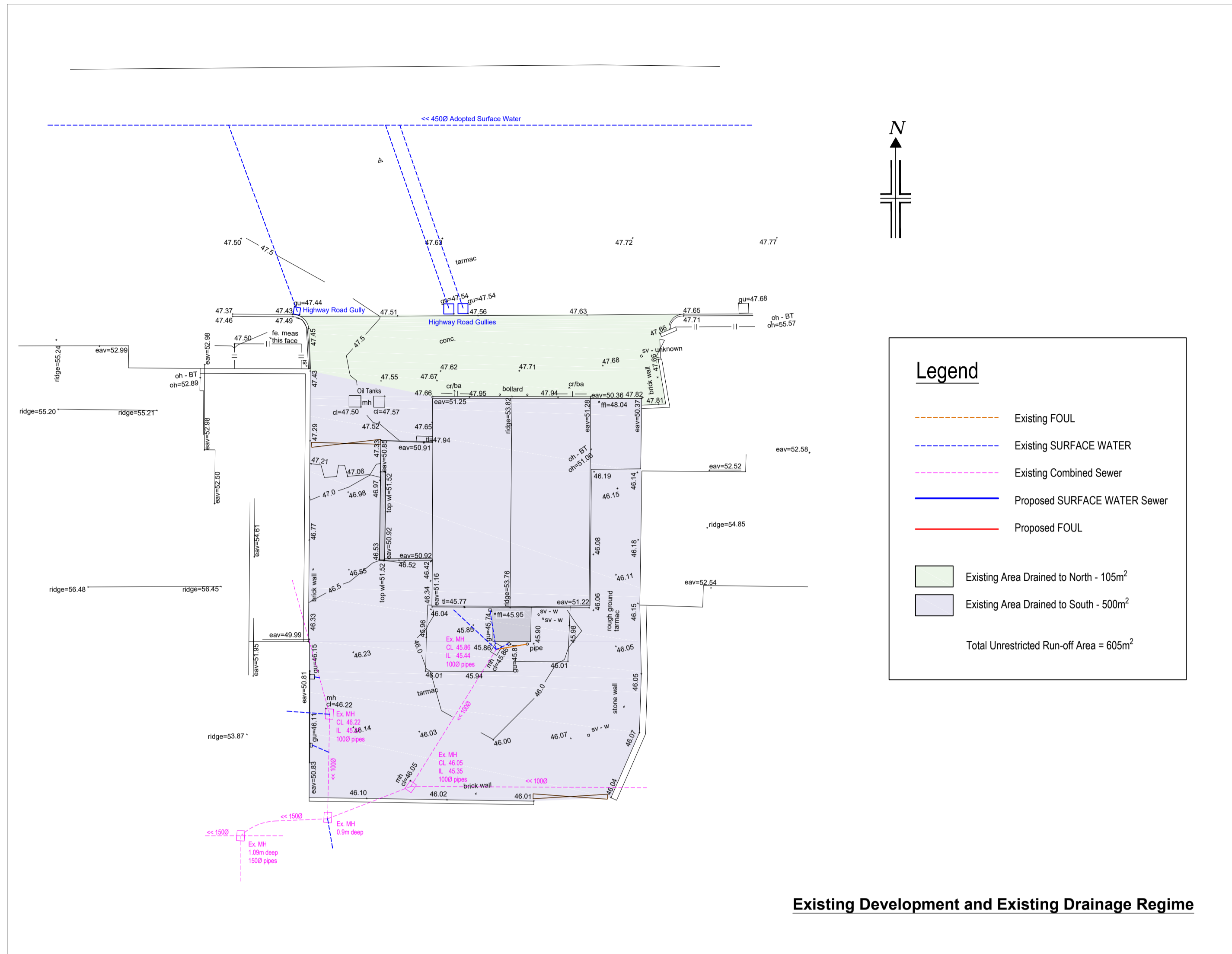

P1	25/09/25	For Approval	GS	DLW	GS
REV	DATE	AMENDMENT DETAILS	DRAWN	CHECKED	APPROVED
<b>DNM Holdings LTD</b>					
<b>Whalley Motors Site, Whalley</b> <b>Existing &amp; Outline Drainage Proposal</b> <b>showing contributing areas</b>			Drwg No.	Rev.	
			<b>D4707-D-01</b>	<b>P1</b>	
			Scale	Sheet Size	
			<b>1:200</b>	<b>A1</b>	
<b>PSA DESIGN</b> PSA Design Ltd The Old Bank House, 6 Berry Lane, Longridge, Preston, PR3 3JA Tel: 01772 786066 www.psadesign.co.uk mail@psadesign.co.uk			Date		
			<b>25th Sept 2025</b>	Date	
Drawn	Checked	Approved	GS	DW	GS

## **Appendix F**

### SW Drainage Model / Calculations

**Design Settings**

Rainfall Methodology	FSR	Maximum Time of Concentration (mins)	30.00
Return Period (years)	1	Maximum Rainfall (mm/hr)	50.0
Additional Flow (%)	0	Minimum Velocity (m/s)	1.00
FSR Region	England and Wales	Connection Type	Level Soffits
M5-60 (mm)	19.000	Minimum Backdrop Height (m)	0.200
Ratio-R	0.300	Preferred Cover Depth (m)	1.200
CV	0.750	Include Intermediate Ground	✓
Time of Entry (mins)	4.00	Enforce best practice design rules	✓

**Nodes**

Name	Area (ha)	T of E (mins)	Cover Level (m)	Diameter (mm)	Easting (m)	Northing (m)	Depth (m)
IC1	0.010	4.00	47.000	450	773.625	430.525	1.200
Silt Trap			46.200	450	773.628	420.072	1.000
IC2	0.014	4.00	46.100	450	787.895	413.819	0.520
Control			46.100	500	773.629	413.816	0.670
Existing			46.050	450	774.847	411.277	0.700

**Links**

Name	US Node	DS Node	Length (m)	ks (mm) / n	US IL (m)	DS IL (m)	Fall (m)	Slope (1:X)	Dia (mm)	T of C (mins)	Rain (mm/hr)
1.000	IC1	Silt Trap	10.453	0.600	45.800	45.500	0.300	34.8	100	4.13	48.4
1.001	Silt Trap	Control	6.256	0.600	45.500	45.430	0.070	89.4	100	4.26	47.8
2.000	IC2	Control	14.266	0.600	45.580	45.430	0.150	95.1	100	4.30	47.7
3.000	Control	Existing	2.816	0.600	45.430	45.350	0.080	35.2	100	4.34	47.5

Name	Vel (m/s)	Cap (l/s)	Flow (l/s)	US Depth (m)	DS Depth (m)	Σ Area (ha)	Σ Add Inflow (l/s)	Pro Depth (mm)	Pro Velocity (m/s)
1.000	1.311	10.3	1.3	1.100	0.600	0.010	0.0	24	0.891
1.001	0.814	6.4	1.3	0.600	0.570	0.010	0.0	31	0.640
2.000	0.789	6.2	1.8	0.420	0.570	0.014	0.0	37	0.685
3.000	1.304	10.2	3.1	0.570	0.600	0.024	0.0	38	1.145

**Pipeline Schedule**

Link	Length (m)	Slope (1:X)	Dia (mm)	Link Type	US CL (m)	US IL (m)	US Depth (m)	DS CL (m)	DS IL (m)	DS Depth (m)
1.000	10.453	34.8	100	Circular	47.000	45.800	1.100	46.200	45.500	0.600
1.001	6.256	89.4	100	Circular	46.200	45.500	0.600	46.100	45.430	0.570
2.000	14.266	95.1	100	Circular	46.100	45.580	0.420	46.100	45.430	0.570
3.000	2.816	35.2	100	Circular	46.100	45.430	0.570	46.050	45.350	0.600

Link	US Node	Dia (mm)	Node Type	MH Type	DS Node	Dia (mm)	Node Type	MH Type
1.000	IC1	450	Manhole	PCC	Silt Trap	450	Manhole	PCC
1.001	Silt Trap	450	Manhole	PCC	Control	500	Manhole	PCC
2.000	IC2	450	Manhole	PCC	Control	500	Manhole	PCC
3.000	Control	500	Manhole	PCC	Existing	450	Manhole	PCC

**Manhole Schedule**

Node	Easting (m)	Northing (m)	CL (m)	Depth (m)	Dia (mm)	Connections	Link	IL (m)	Dia (mm)	
IC1	773.625	430.525	47.000	1.200	450		0	1.000	45.800	100
Silt Trap	773.628	420.072	46.200	1.000	450		1	1.000	45.500	100
							0	1.001	45.500	100
IC2	787.895	413.819	46.100	0.520	450		0	2.000	45.580	100
Control	773.629	413.816	46.100	0.670	500		1	2.000	45.430	100
							2	1.001	45.430	100
							0	3.000	45.430	100
Existing	774.847	411.277	46.050	0.700	450		1	3.000	45.350	100

**Simulation Settings**

Rainfall Methodology	FSR	Analysis Speed	Detailed
Rainfall Events	Singular	Skip Steady State	x
FSR Region	England and Wales	Drain Down Time (mins)	240
M5-60 (mm)	19.000	Additional Storage (m³/ha)	20.0
Ratio-R	0.300	Starting Level (m)	
Summer CV	0.750	Check Discharge Rate(s)	x
Winter CV	0.840	Check Discharge Volume	x

**Storm Durations**

15 | 30 | 60 | 120 | 180 | 240 | 360 | 480 | 600 | 720 | 960 | 1440

Return Period (years)	Climate Change (CC %)	Additional Area (A %)	Additional Flow (Q %)
1	0	0	0
30	40	0	0
100	50	0	0

**Node Control Online Orifice Control**

Flap Valve	x	Design Depth (m)	0.600	Discharge Coefficient	0.600
Replaces Downstream Link	x	Design Flow (l/s)	2.0		
Invert Level (m)	45.430	Diameter (m)	0.035		

**Node Silt Trap Depth/Area Storage Structure**

Base Inf Coefficient (m/hr)	0.00000	Safety Factor	2.0	Invert Level (m)	45.500
Side Inf Coefficient (m/hr)	0.00000	Porosity	1.00	Time to half empty (mins)	46

Depth (m)	Area (m <sup>2</sup> )	Inf Area (m <sup>2</sup> )	Depth (m)	Area (m <sup>2</sup> )	Inf Area (m <sup>2</sup> )	Depth (m)	Area (m <sup>2</sup> )	Inf Area (m <sup>2</sup> )
0.000	19.3	19.3	0.300	19.3	24.0	0.301	0.0	24.0

**Results for 1 year Critical Storm Duration. Lowest mass balance: 100.00%**

Node Event	US Node	Peak (mins)	Level (m)	Depth (m)	Inflow (l/s)	Node Vol (m <sup>3</sup> )	Flood (m <sup>3</sup> )	Status
15 minute summer	IC1	9	45.828	0.028	1.3	0.0091	0.0000	OK
30 minute winter	Silt Trap	24	45.542	0.042	1.6	0.8096	0.0000	OK
15 minute winter	IC2	10	45.617	0.037	1.8	0.0257	0.0000	OK
30 minute winter	Control	25	45.541	0.111	1.4	0.0218	0.0000	SURCHARGED
30 minute winter	Existing	25	45.369	0.019	0.8	0.0000	0.0000	OK

Link Event (Upstream Depth)	US Node	Link	DS Node	Outflow (l/s)	Velocity (m/s)	Flow/Cap	Link Vol (m <sup>3</sup> )	Discharge Vol (m <sup>3</sup> )
15 minute summer	IC1	1.000	Silt Trap	1.3	1.251	0.129	0.0146	
30 minute winter	Silt Trap	1.001	Control	0.7	0.165	0.106	0.0341	
15 minute winter	IC2	2.000	Control	1.8	0.438	0.290	0.0745	
30 minute winter	Control	3.000	Existing	0.8	0.741	0.076	0.0029	1.8

**Results for 30 year +40% CC Critical Storm Duration. Lowest mass balance: 100.00%**

Node Event	US Node	Peak (mins)	Level (m)	Depth (m)	Inflow (l/s)	Node Vol (m <sup>3</sup> )	Flood (m <sup>3</sup> )	Status
15 minute summer	IC1	9	45.846	0.046	4.4	0.0151	0.0000	OK
60 minute winter	Silt Trap	48	45.732	0.232	4.1	4.5113	0.0000	SURCHARGED
15 minute winter	IC2	11	45.785	0.205	6.2	0.1427	0.0000	SURCHARGED
60 minute winter	Control	48	45.731	0.301	3.0	0.0590	0.0000	SURCHARGED
60 minute winter	Existing	48	45.375	0.025	1.3	0.0000	0.0000	OK

  

Link Event (Upstream Depth)	US Node	Link	DS Node	Outflow (l/s)	Velocity (m/s)	Flow/Cap	Link Vol (m <sup>3</sup> )	Discharge Vol (m <sup>3</sup> )
15 minute summer	IC1	1.000	Silt Trap	4.4	1.270	0.427	0.0569	
60 minute winter	Silt Trap	1.001	Control	-1.8	-0.226	-0.276	0.0489	
15 minute winter	IC2	2.000	Control	5.6	0.717	0.906	0.1116	
60 minute winter	Control	3.000	Existing	1.3	0.859	0.131	0.0044	8.2

**Results for 100 year +50% CC Critical Storm Duration. Lowest mass balance: 100.00%**

Node Event	US Node	Peak (mins)	Level (m)	Depth (m)	Inflow (l/s)	Node Vol (m <sup>3</sup> )	Flood (m <sup>3</sup> )	Status
120 minute winter	IC1	86	46.071	0.271	2.1	0.0884	0.0000	SURCHARGED
120 minute winter	Silt Trap	86	46.069	0.569	3.5	5.8901	0.0000	FLOOD RISK
120 minute winter	IC2	86	46.073	0.493	3.0	0.3440	0.0000	FLOOD RISK
120 minute winter	Control	86	46.067	0.637	2.8	0.1249	0.0000	FLOOD RISK
120 minute winter	Existing	86	45.380	0.030	2.0	0.0000	0.0000	OK

Link Event (Upstream Depth)	US Node	Link	DS Node	Outflow (l/s)	Velocity (m/s)	Flow/Cap	Link Vol (m <sup>3</sup> )	Discharge Vol (m <sup>3</sup> )
120 minute winter	IC1	1.000	Silt Trap	2.1	0.941	0.204	0.0818	
120 minute winter	Silt Trap	1.001	Control	-1.4	-0.175	-0.214	0.0489	
120 minute winter	IC2	2.000	Control	2.8	0.440	0.457	0.1116	
120 minute winter	Control	3.000	Existing	2.0	0.951	0.194	0.0059	14.7

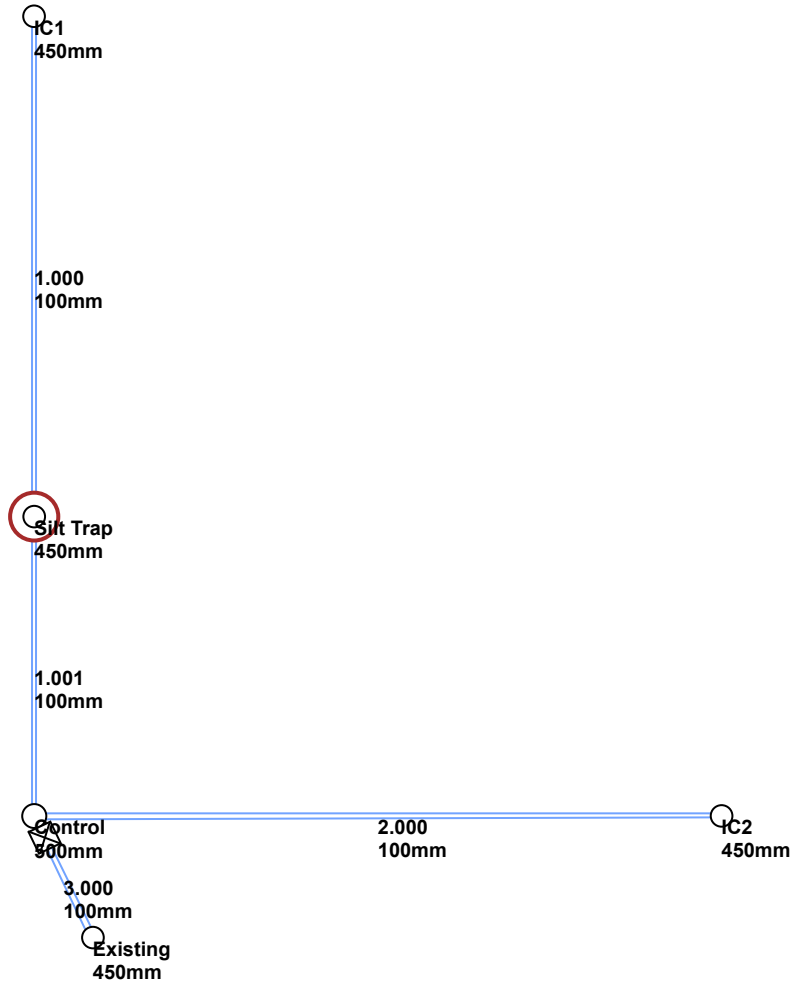

## **Appendix G**

### Maintenance and Management Overview

## **SuDS Maintenance**

This section is intended to give an overview of the operation and maintenance for the drainage features included with the drainage strategy. Where proprietary products are specified, the manufacturer's instructions and recommendations should be followed in priority to this document unless specifically noted otherwise due to project constraints.

The recommended operations and frequencies are typical and should be more frequent initially to ensure that there are no unforeseen issues with the operation. They should then be adjusted to suit the site requirements.

The surface water network has been designed to accommodate the 1 in 100-year storm rainfall event plus an allowance for climate change particular to the requirements of the site. It may be that the exceedance flows above the 1 in 30-year storm rainfall event are stored within the site partially above ground, on non-habitable external landscaping, parking or other space. As the flows are generally being attenuated on site and within SuDS features, there will be a period after storm events where the network is still partially or fully surcharged and is draining down. Where this surcharging is still present after 48hrs, appropriate action should be taken as noted in this section.

## **Components**

The typical SuDS components are highlighted below. This is not an exhaustive list and reference should be made to the SuDS Manual (Ciria C753) for any items not listed.

- Pipes
- Drainage Channels and Gullies
- Permeable Pavements
- Soakaways & Infiltration Trenches
- Attenuation / Infiltration Basins
- Attenuation Storage Tanks
- Oil Separators

A suitable maintenance strategy should be adopted to ensure the drainage network is cleaned regularly and the routine maintenance and cleansing regime should be documented.

It is assumed that the maintenance of the drainage network will be the responsibility of an on-site facilities management team.

A copy of the final construction drainage layout should be provided in the final Operations and Maintenance Manual.

It is recommended that the drainage system is inspected as a minimum twice a year, with the system also being inspected after any major storm event.

Significant sediment deposition is likely in areas used for storage, so a post clean-up operation may be required including the removal of litter, vegetation, sewerage debris and larger objects.

Long-term management practices include monthly sweeping of external paved areas. The sweeping program will remove sand and contaminants directly from paved surfaces before they become mobilised during storm events and transported to the drainage system.

During the winter months, drainage features such as gullies and channels should be cleared of ice, snow, debris or litter

Sediment/material removal should be undertaken in consultation with the environmental regulator to confirm appropriate protocols; especially where run-off is taken from potentially contaminated areas such as the filter drains and the upstream/downstream chambers.

### **Pipes**

Pipes are proprietary products and the materials can vary across the site and as such where used the manufacture's recommendations should be followed.

Pipes are intended to be the main conveyance across the development and where oversized they form the attenuation volume required by the limitation of the discharge rate. They are intended to be dry except during rainfall events. These have been designed to be self-cleaning where possible for smaller diameter pipes, and for larger diameters the risk is reduced due to the overall pipe size.

Access for maintenance is provided through access chambers and manholes.

Regular inspection and maintenance is important to identify areas which may have been obstructed and may not be draining correctly thus exposing the development to a greater level of flood risk.

<b>Maintenance Schedule</b>	<b>Required Action</b>	<b>Frequency</b>
Monitoring (to be undertaken more regularly within the first year of operation and adjusted as required).	Initial Inspection should be provided as post construction CCTV survey.	N/A
Regular maintenance\ inspection	Inspect for evidence of poor operation via water level in chambers. If required, take remedial action.	3-monthly, 48 hours after large storms.
	Check and remove large vegetation growth near pipe runs.	Monthly or as required
Remedial Action	Rod through poorly performing runs as initial remediation.	As required.
	If continued poor performance jet and CCTV survey poorly performing runs.	As required.
	Seek advice as to remediation techniques suitable for the type of performance issue and location.	As required If above does not improve performance.

## Drainage Channels and Gullies

Channels and gullies should be inspected and cleaned in accordance with the manufacturer's details. Channel units can be cleaned through the use of a high-pressure hose; this can be fed into the channel system through access units strategically placed along the channel run. The throat section of channel units should be kept clear at all times to ensure uninterrupted flow of surface water into the drainage channel and any debris within the throat should be removed.

Locking bolts should be replaced and sufficiently tightened, taking care that the bolt heads do not stand above the top surface of the cover or grate. If covers are allowed to move within their frame, this may cause damage to the frame or seating.

Sediment/material removal should be undertaken in consultation with the environmental regulator to confirm appropriate protocols; especially where run-off is taken from potentially contaminated areas such as the car park channels.

<b>Maintenance Schedule</b>	<b>Required Action</b>	<b>Frequency</b>
Monitoring (to be undertaken more regularly within the first year of operation and adjusted as required).	Initial Inspection including channel outlet boxes.	Half yearly and after large storms.
Regular maintenance\ inspection	Litter and debris removal	Monthly or as required.
	Check and remove large vegetation growth near channel runs.	Monthly or as required
	Inspect for evidence of poor operation and/or weed growth. If required take remedial action. Inspect silt accumulation rates and establish appropriate brushing frequencies. Silt can also be caused by adjacent landscaping areas which should be reprofiled to provide a flat area or berm adjacent to the paving.	3-monthly, 48 hours after large storms.
Remedial Action	Inspect access/outlet boxes and rod through poorly performing channels and outlets as initial remediation.	As required.

Regular inspection and maintenance is important for the effective operation of infiltration and attenuation basins. Attenuation tanks contain proprietary products and as such where used the manufacturer's recommendations should be followed

Access points should be established to allow for visual inspection and jetting as appropriate.

Silt traps must be installed prior to all inlets.

<b>Maintenance Schedule</b>	<b>Required Action</b>	<b>Frequency</b>
Monitoring (to be undertaken more regularly within the first year of operation and adjusted as required).	Inspect inlets, outlets and overflows for blockages and clear if required. If faults persist rodding may be required.	Monthly for three months after installation then annually
	Survey inside of tank for sediment build up and remove if necessary	After 1 year and then every 5 years or as required
Remedial Actions	Repair/rehabilitation of inlets/outlets.	As required.
Regular Maintenance	Inspect and identify any areas that are not operation correctly and if necessary take remedial action	Monthly for three months after installation then annually
	Remove debris from catchment surface (where it may cause risk to performance)	As required
	Remove sediment from pre-treatment structures & silt traps	Annually or as required