

- MATERIALS KEY**
1. CONCRETE TILES
  2. BRICKWORK
  3. UPVC WINDOWS/DOORS

EXISTING NORTH REAR ELEVATION 1

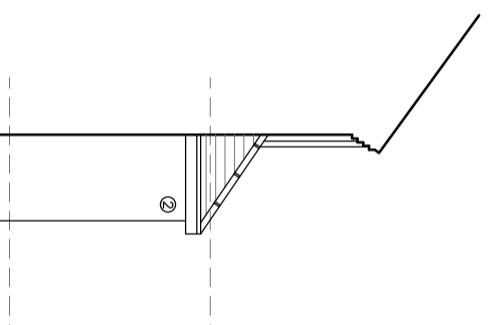

EXISTING WEST SIDE ELEVATION 2

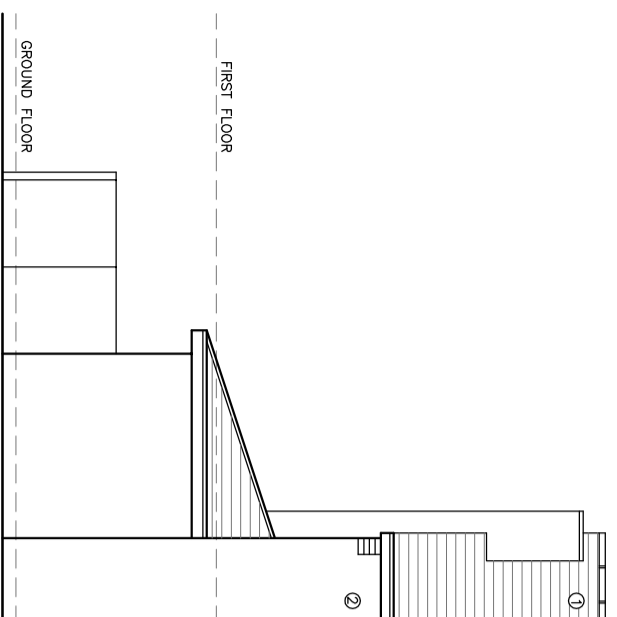

EXISTING SOUTH FRONT ELEVATION 3

EXISTING EAST SIDE ELEVATION 4

©二零一四年 11月 2020 11 The Drawing is to be used in conjunction with all other project associated drawings and information. Do not scale from this drawing. Report all errors, omissions and discrepancies to drawing officer prior to construction or installation. This drawing is copyrighted the property of one architects ltd

 <b>Robinson Barn</b> Worston Clitheroe Lancs BB710A		 Architects Registration Board	
Private Residential   Housing   Commercial   Conservation   Domestic Tel: 01200 441729 Email: info@qw+qarchitects.com   Web: www.qw+qarchitects.com			
Client	<b>MR &amp; MRS WHITTAKER</b>	Scale	<b>1:100</b>
Project	<b>12 KINGSMILL AVE WHALLEY</b>	Drawing Title	<b>EXISTING ELEVATIONS</b>
Drawn By	<b>AW</b>	Drawing Status	<b>PLANNING</b>
Checked	<b>AW</b>	Job Number	<b>25-071</b>
Revision	<b>A</b>	Drawing Number	<b>PL04</b>
First Issue	<b>-</b>		