

**11 St Peter's Close,
Clayton-Le-Dale,
Blackburn
Lancashire
BB1 9HH**

**Preliminary Ecological Survey & Assessment
in Respect of Bat Species and Nesting Birds.**

**Surveyor- Mike Fisher.
(Bat Survey Licence Level 2 Class Survey Licence WML CL18).
(Bat Roost Visitor Level 1 Class Survey Licence WML CL15).**

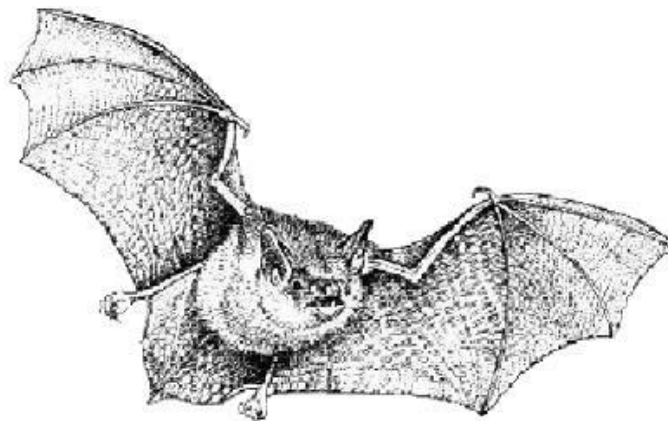

Echo Calls Bat Surveys.

25th January 2026.

1. Introduction.

1.1 Reason for Survey.

As part of the process to obtain planning permission to develop the site, a preliminary ecological survey and assessment, including a daytime evidence and opportunity bat survey, and a current nesting bird survey were requested, on the targeted dwelling and its extensions, and also on any trees, shrubs, and hedgerows growing within the overall site boundaries. The purpose of these surveys was to provide evidence on habitats, and protected species, within the site boundaries, as part of the Local Development Framework (UDP Policy EN9).

1.2 Survey Aims.

The aims of this preliminary ecological assessment were to:

- Inform the Local Planning Authority, on the nature conservation value of the site, and its surrounding area.
- To assess the site for the presence or potential, for protected species within the proposed development site, by doing a detailed inspection of both the exterior and interior of any structures, to look for features that bats could use for entry/exit, and for roosting, and also to search for bats themselves.
- To enable the client to comply with legislation afforded to protected sites and species.
- To highlight the presence of any habitats or species of ecological importance, including Habitats and Species of Principal Importance (NERC Act, 2006).
- To identify any ecological constraints in relation to the proposed project, and any future development in the site.
- To establish the need for any further surveys and assessments.
- To make nature conservation recommendations, and identify opportunities for ecological enhancement and biodiversity gain within the proposals.
- To identify the need for a Natural England Bat Development Licence (required if a roost is identified).

1.3 The Site.

The site consisted of a large semi-detached dwelling with its extensions, all located within a large plot of land, connected by its drive to the western edge of St Peters Close, in the Clayton-Le-Dale area of Blackburn, in Lancashire. The whole complex and its surrounding land from now on are referred to as the "site", at OS grid reference: SD 67749 32823, (refer to **Fig 1 - The Site Location**).

1.4 The Buildings.

The building was a large two-story semi-detached dwelling, with a large extension attached to the northern elevation, both positioned within a sizable area of land, and all parts of the dwelling were surveyed.

1.5 Surrounding Land.

The targeted dwelling was positioned centrally within its own grounds, in a rough south-east to north-west orientation, and surrounded within the site boundaries, by a mixture of gardens, a car parking area, an open-sided carport and a large patio.

The dwelling was located at the eastern end of a large area of housing, most of which were of different sizes and layouts, and the majority of which, had gardens containing some trees and shrubs, and which were bordered by a combination of fencing, low brick walls and hedgerows.

Beyond the properties to the north of the site ran Blackburn Road, in an approximate north-east to south-west direction, beyond which further north, were large areas of open pasture bordered mainly by lines of hedgerow and the odd length of fencing.

Approximately 200m to the north-west of the site was a newly built cattle shed, located in its own fenced off plot of land. Whilst 300m to the north-east were the buildings and grounds belonging to Salesbury Church of England Primary School, with further fields beyond, bordered by lines of mature trees and shrubs, together with the odd drainage ditch.

Positioned 200m beyond the housing to the east, were the buildings and grounds belonging to Wilpshire Wanderers Football Club, and its neighbouring Salesbury Memorial Hall, together with further housing to the east.

To the south of the site were large areas of open pasture, mostly bordered by lines of fragmented hedgerow, within which some trees and shrubs grew. Close to the western border of the targeted site, was a long track running in a southerly direction, until it reached a wastewater treatment plant, approximately 360m to the south-west of the site, alongside Showley Brook, which flowed in an east to west direction, into which a number of small ditches and streams ran.

Other than the above-mentioned habitats, and some small ephemeral ponds, there were no large bodies of water, or large areas of woodland, anywhere else within the surrounding area, (refer to **Fig 1 -The Site Location, Fig 2 – Google Map of Area, Fig 3 – Main Plan Showing the Local Area and Habitats, Fig 4 - Plan Showing Photographs from Preliminary Daylight Evidence and Opportunity Survey and Assessment, and Fig 5 - Plan Showing Results from Preliminary Daylight Evidence and Opportunity Survey and Assessment.**

2. Methods

2.1 Risk Assessment, Possible Hazards.

The required access to the site was easy, and the elevations of the dwelling and its extensions, could all be easily searched. All parts of the building was in excellent condition, and the gardens were reasonably well maintained without difficult obstacles, and as such, there were no more hazards, other than those normally associated with surveying both the inside and outside of these types of building and gardens.

2.2 Methodology of Bat Surveys.

A number of factors are used for the survey methodology, which include:

- Knowledge of bat species relevant to the site location, and geographical range.
- Nature of the immediate, and surrounding habitat, in relation to foraging opportunity.
- Presence/absence of roost potential.
- Value of roost potential – if present.
- Condition of nearby trees, shrubs, and any water bodies.

2.3 Preliminary Ecological Appraisal.

The preliminary ecological appraisal (PEA) of the site took place on 15th January 2026, and was carried out in order to assess the site, to search for evidence of current bat occupation, (including recent and historic use). It comprised a search for bats, bat droppings, bat urine stains, remains of invertebrate or lepidopteran prey, any grease marks from repeated contact, or the passage by bats

through narrow roost accesses, or against surfaces, and any other signs of bat occupation, and at the same time looking for evidence of either current or historical nesting birds, active nests and feathers.

Areas within the dwelling searched were:

- Inside, all parts of the dwelling, its open carport extension and the contained boiler room, together with any roof voids and similar, where bats could roost, also on the roof floor, roof trusses, and also on stored items, spider webs, and other places where droppings, or prey remains may collect. Likewise, noting any noises such as scratching and squeaking which may be made by roosting bats.
- Outside the complex, the eaves, gables, soffits, and walls for signs of potential bat access holes, also, the ground, windowsills, and any other surfaces, such as low walls, refuse bins, garden furniture, vehicles, or pieces of equipment and other items, which may occur underneath the eaves, and around the perimeter of the buildings, any of which may catch bat droppings.

The optimum time to investigate buildings for evidence of a bat roost, is between May and September, however, these can sometimes be done earlier or later in the year, and are weather and temperature dependant.

However, preliminary evidence and opportunity surveys and assessments, may be conducted outside of this time, and can often provide conclusive results, which can save expense and time for Planning Applicants.

The habitats and any trees surrounding the site, were assessed for their suitability for use by foraging and commuting bats.

All evidence of current or previous nesting bird species observed during the survey, was recorded.

2.4 Equipment.

Equipment used consisted of close-focus binoculars, SLR camera, an industrial endoscope camera, ladders, a powerful hand-held torch, and a separate Darkbeam LED ultraviolet flashlight.

3. Results

3.1 Daylight Survey.

3.1.1 Weather.

The weather conditions at the start of the survey on 15th January 2025, were reasonable. At the time of the survey, it was dry with a mixture of sunny periods and some cloud cover, and a gentle breeze, (Beaufort Scale 3), and as the temperature taken during the survey was 7°C, such conditions were acceptable for a survey of this type.

3.2 Possible Roost Sites.

3.2.1 The Buildings.

There was a large, semi-detached dwelling its carport extension and boiler room, all positioned centrally within the overall site.

3.2.2 The Dwelling.

The targeted house was a square, two-story dwelling, constructed entirely from brick with a pitched roof covered in underlined concrete tiles, and with a fully insulated roof void. There were dormer windows in both the ground and first floors of the eastern elevation, and which had flat roofs covered in felt, but with neither roof voids or insulation. Also, there were two further single-storied dormers in the western elevation, each built from brick, with flat, felt covered roofs with neither insulation nor roof voids.

Attached externally to the northern elevation of the dwelling at its north-eastern corner, was a single storied carport extension. This was constructed from brick, but the majority of both the northern and eastern elevations had no walls, and were completely open, however the top half of the eastern elevation was covered in Upvc planking attached to a wooden frame. Whilst attached to its western elevation was a rectangular brick-built boiler-room extension. The roof of which was flat, and constructed from corrugated concrete sheeting, mounted upon timber purlins, all supported by metal beams.

The main part of the dwelling was currently unoccupied, but was still heated and insulated, and was in an overall excellent, well-maintained condition, with sound brickwork, and well-sealed roofs, and soffits. Also, although the voids were currently being used for storage, the voids themselves could easily be searched, and as an internal survey, found no bat droppings, any invertebrate or lepidopteran prey remains, neither was any bat fur grease staining seen. nor any urine staining observed in the ultraviolet light emitted from the Darkbeam LED UV flashlight, and therefore, all parts of the dwelling and the extensions were judged to be of low roost suitability, (refer to **figs 3, 4 and 5, and photos 1 to 22**).

The carport extension was currently being used for the storage of various types of equipment and building materials, but although it was in a reasonable structural condition, being sound and well maintained, two of the elevations were open, which were potential access points for bats to enter into the carport. However, as the carport was neither heated nor insulated, it would be very damp, draughty and cold throughout most of the year, and therefore it was deemed unsuitable for either daytime roosting bats, or breeding bats. Also, as frost and inclement bad weather was very likely to penetrate the interior of the carport, in the colder months, it did not offer the optimum humidity, and constant low temperatures that are required for hibernating bats. As a full internal search had found neither bat droppings, nor any other sign of bat occupation, the carport therefore was judged to be of low bat roosting suitability, (refer to **figs 3, 4 and 5, photos 5 to 11, 13, 14, 21 and 22**).

There were limited potential bat access points however, and these were:

- There was an open vent pipe, positioned at the upper south-western corner of the carport, and an external search of the pipe and the brickwork around it, found neither bat droppings any invertebrate prey remains, nor any urine staining. Also, an internal examination of the pipe using an endoscope camera, found it to be fully meshed internally, and therefore was deemed to offer no bat roosting suitability, (refer to **figs 3, 4 and 5, and photos 9 to 14**).
- Part of the western soffit had become loose and was hanging down, however a search of the underside of the roof, and the soffit itself using close focus binoculars, and also a search of the wall and floor beneath it, found neither droppings nor urine staining, and it was deemed that the hanging soffit was not being used for any type of bat roosting, (refer to **figs 3, 4 and 5, and photos 12, 13 and 17**).

No evidence of either current or historical roosting bats was detected in, on, or around any part of the dwelling. or its extensions, either internally or externally, nor was there any evidence of current or historic use by roosting bats detected anywhere else within the surrounding site.

The search also found no evidence to suggest that any part the complex, or anywhere else in the nearby site, had been used historically by either nesting or roosting birds. It was also surmised that

due to the time of year, most bird species will not have started breeding for the 2026 nesting season, (Refer to **Appendix 1**).

3.2.4 Trees and Shrubs.

There were some trees and shrubs, growing mostly within the western part of the site, and where possible these were all inspected. However, none were found to have any lifted bark, canker damage, cracks, or any holes suitable for roosting bats, and as such, all were judged to be Category 3 (of negligible value for roosting bats) in accordance with **Appendix 2**.

It was thought likely that some of this vegetation could be used by nesting birds during the nesting season, but at the time of the survey, although there was some bird activity in and around the site, no active nests were found amongst the vegetation, and it was also surmised that due to the time of year, although some bird species may be establishing territories amongst the vegetation, for the upcoming 2026 nesting season, none will have yet commenced breeding, (Refer to **Appendix 1**).

3.2.3 Foraging Potential and Alternative Bat Roost Potential.

The site containing the targeted building complex was at the western end of St Peters Close, and consisted of a large dwelling, positioned centrally within its own grounds, in a rough south-east to north-west orientation, and surrounding the complex was a mixture of gardens, car parking area, an open-sided carport, and a large patio.

St Peters Close itself, ran along the southern edge of a large housing estate which consisted of a large number of dwellings of different sizes and layouts, the majority of which had gardens containing some trees and shrubs, and which were bordered by a combination of fencing, low brick walls, and hedgerows. Whilst the northern edge of the estate consisted of Blackburn Road, which ran in an approximate north-east to south-west direction, beyond this further north, were large areas of open pasture bordered mainly by lines of hedgerow, and the odd length of fencing.

Positioned a short distance away to the north-west of the site was a newly built cattle shed, located in its own fenced off plot of land. Whilst to the north-east were the buildings and grounds, belonging to Salesbury Church of England Primary School, with further fields beyond, bordered by lines of mature trees and shrubs, together with the odd drainage ditch.

To the east of the site, there were the buildings and grounds belonging to Wilpshire Wanderers Football Club and its neighbouring Salesbury Memorial Hall, and with further housing beyond, and with large areas of open pasture, mostly bordered by lines of fragmented hedgerow trees and shrubs to the south of the site. Running close to the western boundary of the site was a long track which ran in a southerly direction, until it reached a wastewater treatment plant, positioned to the south-west of the site, alongside Showley Brook which flowed in an east to west direction, and into which, a number of small ditches and streams ran into.

All of the aforementioned features together with other nearby buildings, offered some linear features suitable for foraging bats such as Common Pipistrelle, (*Pipistrellus pipistrellus*), and possibly other bat species, to help them navigate and commute, and to hunt along for their insect prey, (refer to **Paragraph 1.5**).

In accordance with the "Bat Survey, Good Practice Guidelines" (Bat Conservation Trust 2016), it says, "A structure with one or more potential roost sites that could be used opportunistically by individual bats could be classed as roosting habitat. However, if these potential roost sites do not provide enough space, shelter, protection, appropriate conditions, and/or suitable surrounding habitat to be used on a regular basis, or by large numbers of bats (i.e., unlikely to be suitable for maternity or hibernation), then they are of low bat roost suitability", (Refer to **Appendix 2**).

The dwelling and its open sided extension both fitted these criteria, and as there were a number of small ponds and some areas of trees, shrubs, and hedgerow in the overall surrounding vicinity, all

of which offered suitable bat foraging habitat. However, both the dwelling complex and the surrounding site were assessed to offer only low to moderate suitability for roosting bats, primarily pipistrelle species, but it was thought that small numbers of other species could be present.

It was considered that other buildings, especially dwellings, in the surrounding area could offer greater potential as bat roosts. Bats favour tall, heated building whilst breeding.

4. Conclusions.

4.1 In summary, during the current survey undertaken on 15th January 2025, by Echo Calls Bat Surveys, no current or historic evidence of roosting bats was found in any part of the targeted complex, or elsewhere within the overall site.

4.2 Although all parts of the dwelling and its dormers were currently unoccupied, they were still fully heated, and insulated, and were in an excellent overall condition, with well-sealed walls, windows, doors, roofs, soffits and gables, all resulting in a building complex with an overall low bat roosting suitability, (Refer to **Appendix 2**).

4.3 The attached open extension and its included boiler room, were also in a reasonable condition, being sound, and containing the central heating boiler, and was also used for the storage of equipment and miscellaneous items, with negligible internal bat roosting potential. Both of these were neither heated nor insulated. and due to the open sides of the carport, they would be damp, draughty and cold throughout most of the year, and therefore they were deemed unsuitable for either daytime roosting bats, or breeding bats. Also, as frost and inclement bad weather was very likely to penetrate the interior of the extension and boiler room in the colder months, they did not offer the optimum humidity, and constant low temperatures that are required for hibernating bats, and therefore they were also judged to be of low bat roost suitability, (Refer to **Appendix 2**).

4.4 None of the trees, shrubs, or hedgerow growing either within the site, or close by around the site boundaries, offered any cracks, lifted bark or holes, that could be used by roosting bats of any species, and therefore, they were all concluded to offer low bat roost suitability, (refer to **Appendix 4**).

4.5 The adjacent habitats had the potential to support reasonable numbers of foraging bats of varying species, and it was concluded that since there is currently no evidence of the presence of bat roosts within any part of the complex, that any proposed modifications to the dwelling and its extensions, will not have significant implications on the population status of local bat species. There will not be requirement for an EPS mitigation licence (as issued by Natural England) but as a measure of best-practice, precautionary measures should be applied as described in section 5 below.

4.6 It was also concluded that since no evidence of currently roosting bats, or evidence of either recent or historic bat occupation had been found during the current surveys carried out on 15th January 2025, then a single visit to the site to carry out a single daylight evidence and opportunity bat survey was considered sufficient for a preliminary assessment of the site, (refer to the 'Bat Worker's Manual' (JNCC 2004) and 'Bat Surveys Bat Surveys – Good Practice Guidelines' (BCT 2023),

4.7 Since bats, particularly pipistrelle species, are opportunistic, an absence of roost evidence within the site, does not preclude the low possibility of small numbers of bats, using the site occasionally in the future and/or at other times of year. It is considered that the likelihood of a significant roost (such as a maternity roost) being established is very unlikely, with lone and/or transient roosting likelihood being negligible.

4.8 It was understood that there may be some site clearance work carried out during the planned development, but that this will be kept to a minimum, and that the trees, shrubs and

hedgerows around the site will be mostly unaffected by the work, and as bats use linear features such as lines of trees or walls, as foraging, navigating and commuting routes, it was concluded that any small loss of the habitats, and any future development works on the site, would not affect the overall foraging or commuting potential for bats in the area.

4.9 All wild birds are protected under the Wildlife and Countryside Act 1981 (as amended) whilst they are breeding. There was potential for the trees and shrubbery both within, and around the sites' perimeter, to be used by birds for both roosting and nesting purposes, but neither active nor historic nests were found during the surveys. It was also surmised that due to the time of year, that although some birds may be setting up territories for the 2026 nesting season, none will have yet started to breed, (Refer to **Appendix 1**).

5. Recommendations.

5.1 The proposed changes to the complex and the addition of further extensions, as laid out in the planning application, can commence with minimal risk to roosting bats or nesting birds, if the following mitigation measures are adhered to.

5.2 The aim of any mitigation is to ensure that any work is carried out in a manner that avoids harm, or significant disturbance to bats, also, to create new enhanced roosting opportunities for bats, both during and after the development. However, a key issue in successful mitigation measures, is the scheduled timing of the works. Ideally, the dwelling and its extensions, (not considered suitable for hibernation), especially the roofs, should be worked on in winter to avoid the possibility of bats moving in and using the building as a spring, summer, or autumn roost after the survey. The safest period will be from the first hard frosts, normally mid-December, until mid-March, although this could be earlier in a warm spring or later in a cold spring.

5.3 As it is likely that the dwelling complex will be worked on at other times, it will be very unlikely however, that roosting bats will be disturbed. It is recommended though, that work starts as soon as possible after this survey, and that any ridge tiles, slates or sheeting over walls and gables affected by the development, be carefully removed by hand, (the ridge and edge tiles, and copingstones, are the features most likely to harbour potential for the support of roosting bats).

5.4 Although the complex had low bat roosting suitability, it is recommended that if the building work is delayed until the middle part of 2026 or beyond, then further surveys may be required, including a suitable number of evening bat emergence surveys and a possible dawn re-entry survey. Also, if more than twelve months elapses between this survey, and any commencement of building work, then the surveys must be repeated, and these need to be carried out under weather conditions suitable for normal bat activity, and when bats are fully active (May to September but is weather dependent).

5.5 As a measure of best practice and in accord with a key principle of National Planning Policy Framework (2012), it is recommended that the re-development scheme for this site, incorporates biodiversity enhancement measures, and an appropriate measure will be the installation of some Schwegler 1FD bat boxes. These will be attached to the newly planned complex after completion of the building works and extensions, and be placed as close to the eaves, or a gable apex as possible. Others are to be erected upon the trees around the site, after the completion of the modernisation. These should be at least 4 metres off the ground, and away from windows or doors, and any climbing plants, to keep the inhabitants of the boxes safe from predators, and disturbance. Also, it is recommended that these measures are implemented to maximise the opportunities for wildlife at the site and obtain a nett gain in biodiversity, (refer to **Appendix 7** for details).

5.6 As there was some potential for both foraging bats, and also for roosting and nesting birds within the trees and hedgerow growing both within the site, around its boundaries, and the habitats beyond the site boundaries, it is recommended that where possible, these should mostly be left untouched, to encourage future bird nesting, and to maintain navigation, foraging and commuting

routes for bats and to obtain further nett gains in biodiversity.

5.7 However, it must be remembered that it is an offence to disturb active birds' nests. It is recommended therefore, that before any commencement of any tree or shrub clearance, any demolition, or new building work, that a careful survey looking for any evidence of nesting birds, is carried out. If evidence of an active bird's nest is detected, then the nest must be left undisturbed, until it is appropriately confirmed that the young birds have fledged. It is recommended therefore to reduce any nest disturbance so that no activity involving people, or their equipment, is carried out within a 3m radius of active nests. If there is any doubt, please refer to the consultant. This guidance is applicable during the bird breeding season which typically extends from March to August inclusive.

5.8 It is also recommended that some wooden nest boxes are to be erected within the shrubbery and vegetation around the site, with some also attached to various parts of all suitable buildings. These are to be erected to mitigate for potential loss of any unidentified nesting opportunities not found during the survey, and after the development. These will be a mixture of open fronted and hole fronted boxes, and are to encourage and enhance future colonisation and nesting by all bird species within the site and to enhance further biodiversity gains within the site, (refer to **Appendix 8** for details).

5.9 No hole or pit should be left uncovered over-night, to ensure that wildlife such as amphibians or hedgehogs are not trapped, and unable to escape. Alternatively, a broad wooden plank or similar can be placed in the excavation to allow animals to escape, a scaffolding board pitched at a maximum 45° angle would be ideal for this.

5.10 During the development, all excavations should be checked first thing each morning, prior to the start of works that day. Any animals found within excavations should be allowed to escape and move off, or are to be carefully removed, and placed within suitable nearby habitat cover, before site works commences for the day.

5.11 It is also recommended, that if any piles of building materials around the site are removed, or disturbed during building works, then this ideally should be undertaken outside the hedgehog hibernating months, November to mid-March. If this is not possible however, a suitably experienced ecologist must be present to oversee all removal, to ensure that no hedgehogs are disturbed or harmed, whilst either hibernating or daytime nesting, (Hedgehogs are a UK BAP Priority species).

5.12 Once all building work has been finally completed within the site, then a full careful search needs to be carried out, amongst any remaining piles of building equipment, or materials, to ensure that neither nesting birds, hedgehogs, or other animals, are disturbed or hurt. Once this has been carried out successfully, only then, can the removal of all materials from the site be carried out.

5.13 It is also recommended that at least one Eco-plate Hedgehog Box should be positioned in the site, in an appropriate location close to a site boundary, to maximise the opportunities for hedgehog within the site, (refer to **Appendix 9** for details).

5.14 Close boarded fences with concrete bases are barriers to animal movement, and It is recommended, that any new perimeter fences along the boundaries are not to be sealed at their bases. Where possible, hedgerows are to be used instead, with timber post and wire fencing also serving to enforce boundary lines, without prohibiting wildlife movements. If any boarded or concrete fences are required, it is recommended that there is a 13 cm square gap between the wood and the ground, (greater in some locations. and less in others is not a problem), or if this is not possible, then "hedgehog highways" are to be placed within the overall boundary at regular intervals so that wildlife such as hedgehog and amphibians, can pass into and out of the garden, (refer to **Appendix 10** for details).

5.15 Outdoor lighting is typically a deterrent to wildlife, especially bats and nesting birds, it is therefore recommended, that any future outdoor lighting, installed during the proposed development, be screened, hooded or positioned low at bollard level so that it does not illuminate the roof or eaves, or nearby trees and shrubs in accordance with “Bats and Artificial Lighting at Night”, guidance which has been produced by the Institute of Lighting Professionals in conjunction with the Bat Conservation Trust, (refer to **Appendix 11** for details).

5.16 To enhance the site’s value for wildlife, it is recommended that trees be planted to replace any felled trees, and this is planned as part of the development, and that the trees used for re-planting are British native trees as far as is possible. These trees are more likely to attract insects and are therefore beneficial to foraging bats and other wildlife. Suitable species include: Hawthorn, Rowan, Wild Cherry, Guelder Rose and Crab Apple. These have been chosen for their attractive blossom and fruits. Oak, Ash and Willow species are recommended away from buildings and drains.

5.17 It should be remembered that bats are occasionally found in the most unexpected places. If any bats are found during unsupervised work, work must be stopped immediately, and either the consultant, (07745 268815), or the Bat Conservation Trust, (0345 1300 228), or Natural England (01270 754 00, should be notified, (refer to **Appendix 5** for details). **Failure to do so would be a criminal offence.**

6. Survey Constraints.

Surveying for bats at a specific season of the year, does not provide information of use of the site by bats at other times of the year. The current surveys were undertaken during spring, and reflects past bat activity, and whilst consideration may be given to roosting at other times, there may be no evidence for activities outside the survey period.

As bats can utilise very small cracks and crevices, it is not possible to completely discount their use of some of the buildings around the site, although the survey did not identify any evidence of use. Assessments can however be made of potential use from the survey findings collected, but it may not provide a full picture of site usage.

Small bat roosts and single roosting bats can easily be overlooked. They can be difficult to detect during inspection, as they leave few field signs which can easily be missed during surveys. External signs e.g., droppings, prey remains etc., are also subject to weather and rain, which can often remove the signs prior to an actual survey. This is particularly valid when inspecting trees and shrubs.

7. References

Department for Communities and Local Government (March 2012). National Planning Policy Framework. London

Bat Surveys - good practice guidelines 2nd Edition. Bat Conservation Trust. London. Hundt (2012).

Bat Surveys for Professional Ecologists: Good Practice Guidelines (3rd edition) Collins, J. (2016).

Bats and Artificial Lighting – Bat Conservation Trust (2018)

Bat Workers’ Manual. 3rd Edition. Joint Nature Conservancy Committee. Peterborough. Mitchell-Jones A.J. and McLeish A.P. (Eds). (2004).

Bat Mitigation Guidelines. English Nature, Peterborough. Mitchell-Jones, A.J. (2004).

Designing for biodiversity - A technical guide for new and existing buildings' (RIBA Publishing 2013, 2nd edition)

Wildlife and Countryside Act (1981). H.M.S.O., London.

Habitat Management for Bats. (2001) JNCC. Entwistle, Abigail C. et al.

Bat Tree Habitat Key, 2nd Edition (Andrews, H (ed), (2013).

Landscape and urban design for bats and biodiversity. Bat Conservation Trust (2012)

Bats of Britain and Europe - Schober and Grimmberger. Hamlyn (1993)

The Population Status of Birds in the UK: Birds of conservation concern: 2002-2007. Anon. (2007)

8. Surveyor's Qualifications

The surveyor Mike Fisher is a holder of:

- Natural England Class Licence Registration Number: 2015-10595-CLS-CLS, this is the Bat Survey Level 2 Class Survey Licence WML CL18.
- Natural England Class Licence Registration Number: 2015-10592-CLS-CLS which is the Volunteer Bat Roost Visitor Level 1 Class Survey Licence WML CL15.
- The surveyor also has a licence to disturb and take bats for scientific, educational, or conservational purposes by Countryside Council for Wales (Licence Number S085859/1)

9. Plans & Photographs



Fig 1 - The Site Location



Fig 2 – Google Plan

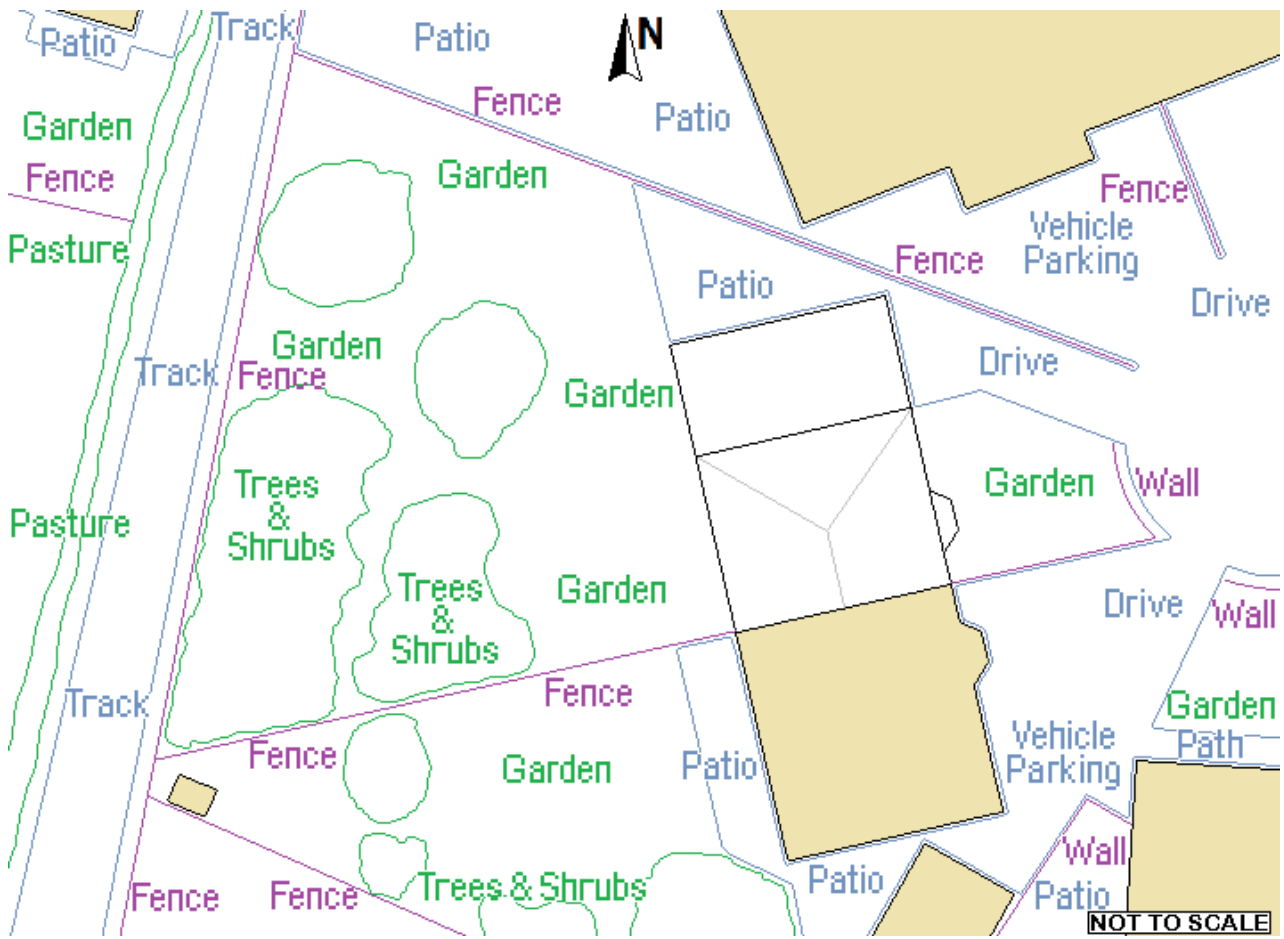

**Fig 3 – Main Plan
Showing the local area and habitats.**

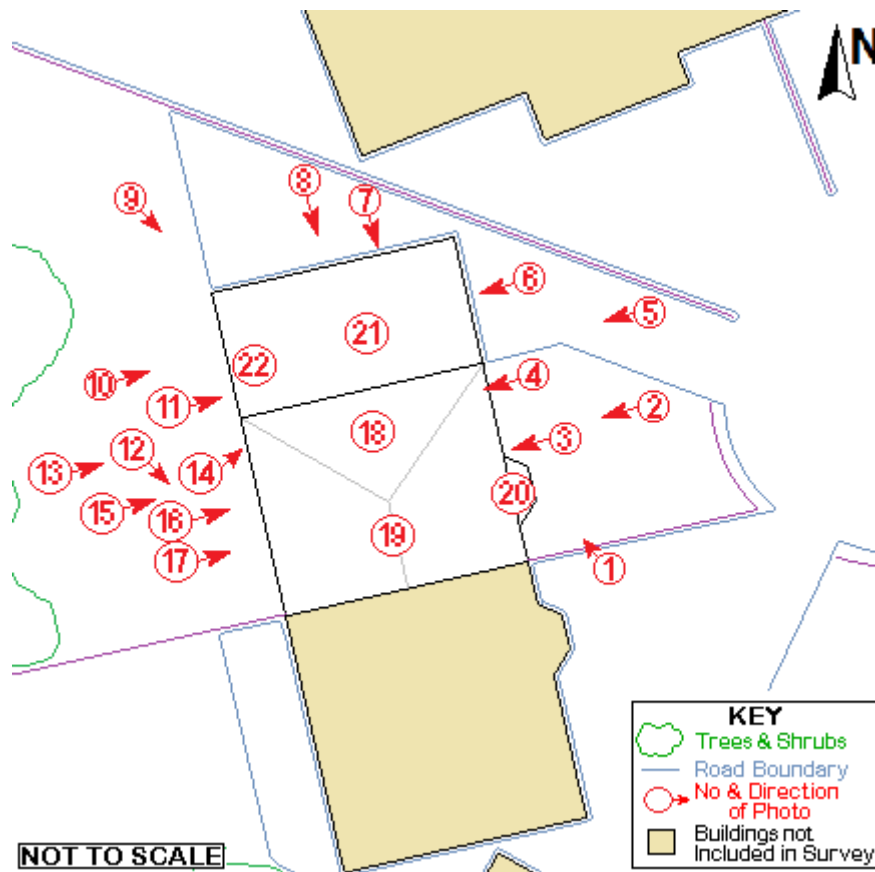

Fig 4 - Plan Showing Photographs from Preliminary Daylight Evidence and Opportunity Survey and Assessment.

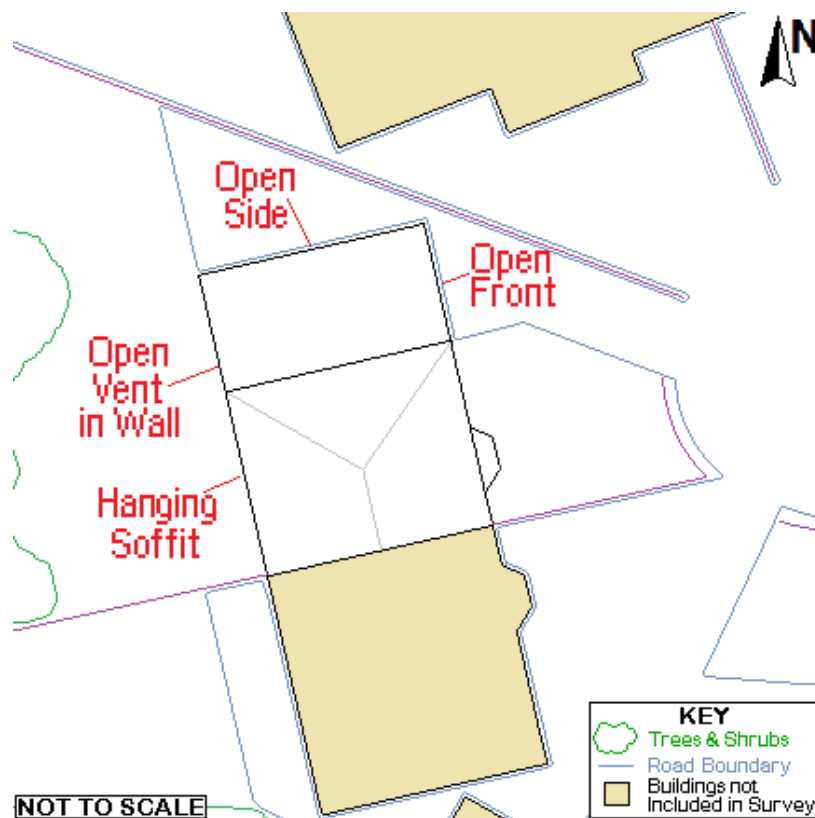

Fig 5 - Plan Showing Results from Preliminary Daylight Evidence and Opportunity Survey and Assessment.



PHOTO 1
South-eastern Elevation



PHOTO 2
Eastern Elevation



PHOTO 3
View of Eastern Roof



PHOTO 4
Underside of Eastern Soffit



PHOTO 5
North-eastern Corner



PHOTO 6
Eastern Elevation of Carport

Open Side



PHOTO 7
Northern Elevation of Carport



PHOTO 8
Northern Elevation of Dwelling



PHOTO 9
North-western Corner of Complex



PHOTO 10
Western Elevation of Carport

Open Vent in Wall



PHOTO 11
South-western Corner of Carport



PHOTO 12
North-western Corner of Dwelling



PHOTO 13
Western Elevation of Dwelling



PHOTO 14
South-western View of Kitchen Dormer



PHOTO 15
Lower Western Elevation of Dwelling



PHOTO 16
Lower South-western Corner of Dwelling



PHOTO 17
View of Western Roof



PHOTO 18
Underside of Southern Main Roof



PHOTO 19
Underside of Main Roof



PHOTO 20
Underside of Internal Upper Eastern Dormer



PHOTO 21
Underside of Carport Roof



PHOTO 22
Underside of Boiler Room Roof

25th January 2026
Mike Fisher, Bat Worker
Holder of Natural England Bat Roost Licence

Disclaimer.

All reasonable effort has been taken to ensure an accurate assessment of the birds and bats at this site. The absence of recorded presence or sign should not be taken as an absolute guarantee that a site is not being used by a particular species. There is also no guarantee that any particular species will not use the site at any time in the future. Survey results for both bird and bat activity may be weather or seasonally dependent. Any interpretation of legislation is based on our understanding and experience of the law. The relevant statutory authority can provide a more definitive interpretation.

This report has been prepared by Echo Calls Bat Surveys with all reasonable skill, care and diligence, within the terms of the Contract with the Client.

No part of this document may be reproduced without the prior written approval of Echo Calls Bat Surveys.

APPENDIX 1: Synopsis of Relevant Legislation.

Bats and the Law

In Britain, all bat species and their roosts are legally protected, by both domestic and international legislation.

This means you will be committing a criminal offence if you:

Deliberately capture, injure or kill a bat.

Intentionally or recklessly disturb a bat in its roost or deliberately disturb a group of bats.

Damage or destroy a bat roosting place (even if bats are not occupying the roost at the time)

Possess or advertise/sell/exchange a bat (dead or alive) or any part of a bat.

Intentionally or recklessly obstruct access to a bat roost.

Licensing

Licenses to permit illegal activities relating to bats and their roost sites can be issued for specific purposes and by specific licensing authorities in each country. These are sometimes called 'derogation licenses' or 'European Protected Species' licenses and are issued under the Habitats Regulations. It is an offence not to comply with the terms and conditions of a derogation Licence. If you carry out work affecting bats or roosts without a Licence, you will be breaking the law.

Who needs to take particular note of the legislation?

Property owners/householders who have a bat roost in their property.

Woodland owners, arboriculturists and foresters.

Pest controllers.

Planning officers & building surveyors.

Architects, property developers, demolition companies, builders and roofers

Which legislation is relevant for bats and roosts?

In England and Wales, the relevant legislation is the Wildlife and Countryside Act (1981) (as amended); the Countryside and Rights of Way Act, 2000; the Natural Environment and Rural Communities Act (NERC, 2006); and by the Conservation of Habitats and Species Regulations (2010).

In Scotland, the key legislation that applies is the Conservation (Natural Habitats &c.) Regulations 1994 (as amended).

In Northern Ireland bats are listed under Schedule 2 of the Conservation (Natural Habitats etc.) Regulations (Northern Ireland) 1995 and in the Republic of Ireland, under Schedule 5 of the Wildlife Act 1976 and Schedule 1 of the European Communities (Natural Habitats) Regulations 1997.

Defenses include:

Tending/caring for a bat solely for the purpose of restoring it to health and subsequent release

Mercy killing where there is no reasonable hope of recovery, (provided that person did not cause the injury in the first place - in which case the illegal act has already taken place).

Penalties on conviction –

People committing bat crimes can face six months' imprisonment and/or unlimited fines. Additionally, any profits made as a consequence of not following lawful process can be confiscated and items used to commit the offences such as vehicles, plant or machinery can be forfeited.

Under the National Planning Policy Framework (2012), it is recommended that the re-development scheme for any site, protected species such as bats, should be a material consideration in planning applications. This has implications for bat foraging areas as well as their roosts.

The National Planning Policy Framework (NPPF) places a clear responsibility on Local Planning Authorities to conserve and enhance biodiversity and to encourage on the consideration that should be given to Protected Species where development may affect them.

The Office of the Deputy Prime Minister (ODPM) Circular 06/2005 provides administrative guidance on the application of the law in relation to planning and nature conservation. This is supported by a guide to good practice entitled 'Planning for Biodiversity and Geological Conservation: Building in Biodiversity' in which paragraphs 5.34 and 5.35 identify that species such as bats are highly dependent upon built structures for survival and that roosts can be easily incorporated into existing and new developments/conversions to benefit these species.

Breeding Birds and the Law.

All wild birds are protected under the *Wildlife and Countryside Act 1981* (as amended), whilst they are actively nesting or roosting. Section 1 of this Act, makes it an offence to kill, injure or take any wild bird, and to intentionally take, damage or destroy the nest of any wild bird while that nest is in use or being built. It is also an offence to take or destroy any wild bird eggs.

Hedgehogs and the Law.

Hedgehogs are protected by British law under Schedule 6 of the Wildlife and Countryside Act 1981, making it illegal to kill or capture them using certain methods. Similar protection exists in Northern Ireland under Schedule 6 & 7 of the Wildlife Order 1985. They are also protected in Britain under the Wild Mammals Protection Act (1996), prohibiting cruelty and mistreatment.

They're listed as a Species of Principle Importance in England under the Natural Environment and Rural Communities (NERC) Act 2006 Section 41, in Wales under the Environment Act 2016, and in Scotland under the Nature Conservation Act 2004. Similarly, hedgehogs are on the Priority Species List for Northern Ireland.

These laws make hedgehogs a material consideration for Local Planning Authorities (LPAs) during the planning process.

Developments should also be consistent with Local Plans (LPs) and Neighbourhood Area Plans (NAPs), some of which may explicitly refer to hedgehog conservation and connectivity of the landscape.

APPENDIX 2: Bat Roost Suitability

Bat Conservation Trust

Table 4.1. Guidelines for assessing the potential suitability of proposed development sites for bats, based on the presence of habitat features within the landscape, to be applied using professional judgement.

Potential suitability	Description	
	Roosting habitats in structures	Potential flight-paths and foraging habitats
None	No habitat features on site likely to be used by any roosting bats at any time of the year (i.e. a complete absence of crevices/suitable shelter at all ground/underground levels).	No habitat features on site likely to be used by any commuting or foraging bats at any time of the year (i.e. no habitats that provide continuous lines of shade/protection for flight-lines, or generate/shelter insect populations available to foraging bats).
Negligible ^a	No obvious habitat features on site likely to be used by roosting bats; however, a small element of uncertainty remains as bats can use small and apparently unsuitable features on occasion.	No obvious habitat features on site likely to be used as flight-paths or by foraging bats; however, a small element of uncertainty remains in order to account for non-standard bat behaviour.
Low	A structure with one or more potential roost sites that could be used by individual bats opportunistically at any time of the year. However, these potential roost sites do not provide enough space, shelter, protection, appropriate conditions ^b and/or suitable surrounding habitat to be used on a regular basis or by larger numbers of bats (i.e. unlikely to be suitable for maternity and not a classic cool/stable hibernation site, but could be used by individual hibernating bats ^c).	Habitat that could be used by small numbers of bats as flight-paths such as a gappy hedgerow or unvegetated stream, but isolated, i.e. not very well connected to the surrounding landscape by other habitat. Suitable, but isolated habitat that could be used by small numbers of foraging bats such as a lone tree (not in a parkland situation) or a patch of scrub.
Moderate	A structure with one or more potential roost sites that could be used by bats due to their size, shelter, protection, conditions ^b and surrounding habitat but unlikely to support a roost of high conservation status (with respect to roost type only, such as maternity and hibernation – the categorisation described in this table is made irrespective of species conservation status, which is established after presence is confirmed).	Continuous habitat connected to the wider landscape that could be used by bats for flight-paths such as lines of trees and scrub or linked back gardens. Habitat that is connected to the wider landscape that could be used by bats for foraging such as trees, scrub, grassland or water.
High	A structure with one or more potential roost sites that are obviously suitable for use by larger numbers of bats on a more regular basis and potentially for longer periods of time due to their size, shelter, protection, conditions ^b and surrounding habitat. These structures have the potential to support high conservation status roosts, e.g. maternity or classic cool/stable hibernation site.	Continuous, high-quality habitat that is well connected to the wider landscape that is likely to be used regularly by bats for flight-paths such as river valleys, streams, hedgerows, lines of trees and woodland edge. High-quality habitat that is well connected to the wider landscape that is likely to be used regularly by foraging bats such as broadleaved woodland, tree-lined watercourses and grazed parkland. Site is close to and connected to known roosts.

a Negligible is defined as 'so small or unimportant as to be not worth considering, insignificant'. This category may be used where there are places that a bat could roost or forage (due to one attribute) but it is unlikely that they actually would (due to another attribute).

b For example, in terms of temperature, humidity, height above ground level, light levels or levels of disturbance.

c Evidence from the Netherlands shows mass swarming events of common pipistrelle bats in the autumn followed by mass hibernation in a diverse range of building types in urban environments (Korsten *et al.*, 2016 and Jansen *et al.*, 2022). Common pipistrelle swarming has been observed in the UK (Bell, 2022 and Tomlinson, 2020) and winter hibernation of numbers of this species has been detected at Seaton Delaval Hall in Northumberland (National Trust, 2018). This phenomenon requires some research in the UK, but ecologists should be aware of the potential for larger numbers of this species to be present during the autumn and winter in prominent buildings in the landscape, urban or otherwise.

In accordance with Table 4.1 of
Bat Surveys for Professional Ecologists: Good Practice Guidelines (4th Edition) Collins J. (ed 2023)

APPENDIX 3: Bat Survey Timings and Frequency.

Table 7.1. Recommended timings for presence/absence surveys to give confidence in a negative result for structures (also recommended for trees where other methods such as PRF inspection are not possible, but unlikely to give confidence in a negative result). To be used in tandem with Table 7.2.

Low roost suitability or PRF-I	Moderate roost suitability	High roost suitability or PRF-M
May to August (structures) No further surveys required (trees)	May to September ^a , with at least one of surveys between May and August ^b	May to September ^a , with at least two of surveys between May and August ^b
<p>a September surveys are both weather- and location-dependent. Conditions may become more unsuitable in these months, particularly in more northerly latitudes, which may reduce the length of the survey season. September surveys are likely to miss maternity roosts due to dispersal before this time, but may pick up mating roosts.</p> <p>b Multiple survey visits should be spread out to sample as much of the recommended survey period as possible; it is recommended that surveys are spaced at least three weeks apart, preferably more. Survey timings should consider the prevailing conditions in the year of survey, which will vary geographically. In years with a cold spring, the surveys should not be started in early May or all completed in May. The surveys should maximise the possibility of detecting maternity roosts, which can switch roosts between pregnancy and lactation, and the optimum coverage includes the pre-parturition, post-parturition and mating periods.</p>		

Table 7.2. Recommended minimum number of survey visits for presence/absence surveys to give confidence in a negative result for structures (also recommended for trees but unlikely to give confidence in a negative result).

Low roost suitability or PRF-I	Moderate roost suitability	High roost suitability or PRF-M
One survey visit. One dusk emergence survey ^a (structures). No further surveys required (trees).	Two separate dusk emergence survey visits ^b .	Three separate dusk emergence survey visits ^b .
<p>a Structures that have been categorised as low potential can be problematic and the number of surveys required should be judged on a case-by-case basis (see para 5.2.44). In some cases, more than one survey may be needed, particularly where there are several buildings in this category.</p> <p>b Multiple survey visits should be spread out to sample as much of the recommended survey period (see Table 7.1) as possible; it is recommended that surveys are spaced at least three weeks apart, preferably more.</p>		

In accordance with Tables 7.1 and 7.2 of
Bat Surveys for Professional Ecologists: Good Practice Guideline (4th Edition) (Collins. J. (ed) 2023).

APPENDIX 4: Bat Tree Assessment Criteria

Criteria for Assessment of Trees in accordance with Category 1 to 3 as defined in Table 8.4 of *Bat Surveys: Good Practice Guidelines 2nd Edition* (Hundt, L. 2012).

CATEGORY	DESCRIPTION	CRITERIA
Known or Confirmed	Confirmed roost	<p>Confirmed roost</p> <p>Evidence found that indicates tree/tree features are being used by bats.</p> <p>Droppings found at the base of the tree, below a cavity.</p> <p>Bats heard 'chattering' inside a feature on a warm day or at dusk</p> <p>Bat(s) observed flying from or to a feature.</p>
1*	Very high value	<p>Trees with multiple, highly suitable features capable of supporting larger roosts.</p> <p>Features of particular significance, suitable for high priority roosts such as maternity roosts, used by large numbers of bats, offering conditions that are uncommon or rare in the local area.</p> <p>Features such as large cavities, extensive branch or trunk splits, also including multiple features in the same tree that offer a diversity of opportunities.</p> <p>Features may also include dense ivy.</p>
1	High value	<p>Trees with definite bat potential supporting fewer suitable features than category 1* trees or with potential for use by single bats.</p> <p>Features which provide a more secure form of roost for small groups of bats and individuals, but may still be quite common types of feature, such as small cavities, minor splits or sparse ivy cover.</p>
2	Moderate value	<p>Trees with no obvious potential, although the tree is of a size and age that elevated surveys may result in cracks or crevices being found; or the tree supports some features which may have limited potential to support bats.</p> <p>A tree which on close inspection the potential roost positions are in some way not ideal. They could be upward facing or holes very low down or cluttered by adjacent branches.</p>
3	Low/Negligible value	<p>Trees that have no features which could be used by bats for roosting (Usually young trees).</p>

APPENDIX 5: Planning Considerations

When considering each planning application, the presence of protected species, such as those listed above, is a material consideration which must be fully considered by the Local Authority when granting planning permission. If a licence from Natural England is required, then prior to issuing any planning consent, the local planning authority will need to be satisfied that there is no reason why such a licence would not be issued. Therefore, in reaching the planning decision the local planning authority will need to have regard to the requirements of the Conservation of Habitats and Species Regulations 2010.

The three licensing tests given in the Regulations must be considered. In summary, these are that:

1. The development is required for the purpose of:
 - preserving public health or public safety,
 - for other imperative reasons of over-riding public interest, including those of a social or economic nature and beneficial consequences of primary importance for the environment.
 - to prevent serious damage to property.
2. There is no satisfactory alternative.
3. The proposal will not be detrimental to the maintenance of the population of the species at a favourable conservation status.

All necessary information would need to be provided to the planning authority as part of the planning application in order to address the above tests.

The Natural Environment and Communities Act (NERC Act) 2006 extended the biodiversity duty set out in the Countryside and Rights of Way (CROW) Act to public bodies and statutory undertakers to ensure due regard to the conservation of biodiversity. The Duty is set out in Section 40 of the Act, and states that:

"Every public authority must, in exercising its functions, have regard, so far as is consistent with the proper exercise of those functions, to the purpose of conserving biodiversity".

The Duty applies to all local authorities, community, parish and town councils, police, fire and health authorities and utility companies. Section 41 (S41) of this Act (the 'England Biodiversity List') also requires the Secretary of State to publish a list of habitats and species that are of principal importance for the conservation of biodiversity in England. This list is used to guide decision-makers such as public bodies, including local and regional authorities, in implementing their duty under section 40(1) of the Act.

Also, Local Authorities must follow the National Planning Policy Framework (NPPF) which provides guidance on the interpretation of the law in relation to wildlife issues and development. For each development proposal considered by the Local Planning Authority the NPPF states that the authority must aim to conserve and enhance biodiversity. If significant harm resulting from a development cannot be avoided (through locating on an alternative site with less harmful impacts), adequately mitigated, or, as a last resort, compensated for, then planning permission should be refused.

APPENDIX 6: Bats: What to do should bats be found during building work

All of the UK's bats and their roosts, are protected by law, (see Appendix 1), so it is important to understand these laws, if you are planning any building or remedial work that may affect or disturb a bat roost. The relevant statutory authority should be initially contacted for advice.

Having bats roosting within a building does not necessarily mean that work cannot be carried out. What it does mean is that the work will need careful consideration, especially in terms of time and materials, so that the area can continue to be used by both bats and people. Therefore, the earlier in the process the bats are taken into account, the less disruption to building plans there will be.

If at any point during either new building work, renovation work, or demolition, one or more bats are found, then all work being undertaken by contractors should stop immediately. All working machinery and contractors should be removed from the area where the bats have been found, and advice sought immediately from one of the following, on how to proceed while causing minimal disturbance to bats.

Advice can either be provided by a professional licensed ecological consultant - Echo Calls Bat Surveys on 07745 268815, the Bat Conservation Trust on 0345 1300 228, or from your Statutory Nature Conservation Organisation (SNCO) , or from Natural England on 01270 754 000.

Depending on the advice given, a licensed bat worker, or suitably qualified Natural England approved representative, will then be sent to site to liaise with the site manager, and Natural England itself. Depending on the advice given, actions will be recommended that may include the safe removal of the bat by the nominated person, only where written or verbal permission has been gained by Natural England.

Works will recommence when Natural England are satisfied that the risk to bats has been removed. If, however, it is determined that the proposed work on site contains more risk to bats than was originally thought, then it is probable that further work will only proceed, under a Natural England Development Licence.

If a bat is found under a tile, slate, flashing or any other covering material, work must stop immediately. If the bat does not fly out immediately, then the area around the roost must be carefully covered over, to protect the bat from the elements and further disturbance, leaving a small gap for bats to escape voluntarily. At this point, advice must be sought as mentioned above. The materials used to cover the occupied bat roost, must be free from liquid, oil, grease and other contaminants.

It is recommended that the handling of bats be avoided wherever possible, but if it absolutely necessary, then to avoid a bat being harmed, gloves must be worn whilst handling the bat. It should be carefully caught, placed in a cardboard box with air holes in the lid, and a small container containing water. The box should then be kept in a very quiet, dark area, away from further disturbance, whilst awaiting the arrival of the licensed bat worker, or Natural England approved representative.

Failure to do any part of this could result in a criminal offence.

APPENDIX 7: Bats: Types of Bat Box.

The aim of any mitigation is to ensure that any work is carried out in a manner that avoids harm or significant disturbance to bats, and also to create new roosting opportunities for bats both during and after the development.

Schwegler 1FD boxes are to be erected to larger trees located along the edges of the site. This type of bat box is a “general all-rounder” and is suitable for all types of bats.

These boxes are to be erected as recommended by the Bat Conservation Trust guidelines which state that

- Ideally, erect the boxes facing so they face in different directions, to provide a range of temperature conditions. For example, boxes facing from south-east to south-west allow the sun to fall on each box for part of the day. During very hot days a south-facing box may overheat, but the other boxes should have some shade during the day.
- Bat boxes should be located close to a linear vegetation feature such as a tree line or hedgerow or to lines of buildings. Some bat species use these features for navigation between their roosting site and feeding ground and to avoid flying in open and exposed areas.
- Ensure that tree branches or other items will not impede the bats’ approach to the box – clear away underneath the box so the bats can land easily before crawling into the box.
- Boxes should be erected at a height of approximately 4m above ground level



Schwegler 1FD Bat Box

This Schwegler 1FD bat box has been developed specifically for smaller bats. The interior and the type and size of the entrance hole match the requirements of smaller species. It features a special layout inside the domed roof, an increased interior height, and two grooved internal wooden front panels with precise spacing between them.

This model has proved highly effective as a nursing area.

Occupants: Small bats such as the Common Pipistrelle (*Pipistrellus pipistrellus*), Soprano Pipistrelle (*Pipistrellus pygmaeus*), Daubenton’s Bat (*Myotis daubentonii*) and Common Long-eared bat (*Plecotus auritus*).

APPENDIX 8: Nesting Birds: Mitigation and Compensation Measures.

Birds are declining throughout the country due to loss of roost and nesting places, and as the development may disturb nesting potential on the site, artificial nests are to be erected to compensate for this possible loss. The erection of artificial nests around the complex, will provide alternative sites for all three species of bird, and make a positive contribution to their conservation.

Making a nestbox suitable for robins and other box builders

What you need

Natural nest holes do not come in standard sizes, so use these dimensions only as a guide. Any plank or sheet of about 15 mm thick weatherproof timber is suitable. However, do not use CCA pressure-treated timber, since the leachates may harm birds. Cut each section as per our plan, which you can download by clicking on the link to the right.

Dimensions

The plan gives measurements for a small and a large box. Use only the first or the second figure throughout. For starlings and great spotted woodpeckers, use the dimensions for the large box; all the others need the small one.

The bottom of the entrance hole must be at least 125 mm from the floor of the nestbox. If it's less, young birds might fall out or be scooped out by a cat. The inside wall below the entrance hole should be rough to help the young birds to clamber up when it's time for them to leave.

Putting it together

Drill drainage holes to the base of the box, and use galvanised nails or screws to assemble. It's always best to leave the box untreated. As it weathers, it will blend into its surroundings. Softwood boxes can be treated with selected water-based preservatives, which are known to be safe for animals, such as Sadolin. Apply it only to the outside of the box, and not around the entrance hole. Make sure the box dries and airs thoroughly before you put it up.

A woodpecker box should be filled with a block of balsa wood, rotting log or wood chips – woodpeckers like to excavate their own nesting cavities.

Do not nail down the lid since you will need to clean out the box in the autumn. Attach the lid with a brass or a plastic hinge that will not rust, or hinge it with a strip of leather or rubber (an old piece of bicycle inner tube will do). Fasten it down with a good catch.

How big does the hole need to be?

The entrance hole size depends on the species you hope to attract:

- 25 mm for blue, coal and marsh tits
- 28 mm for great tits, tree sparrows and pied flycatchers
- 32 mm for house sparrows and nuthatches
- 45 mm for starlings

The small box with 100 mm high open front may attract robins, or pied wagtails. A wren would need a 140 mm high front panel, while spotted flycatchers and blackbirds prefer a low 60 mm front to the box.

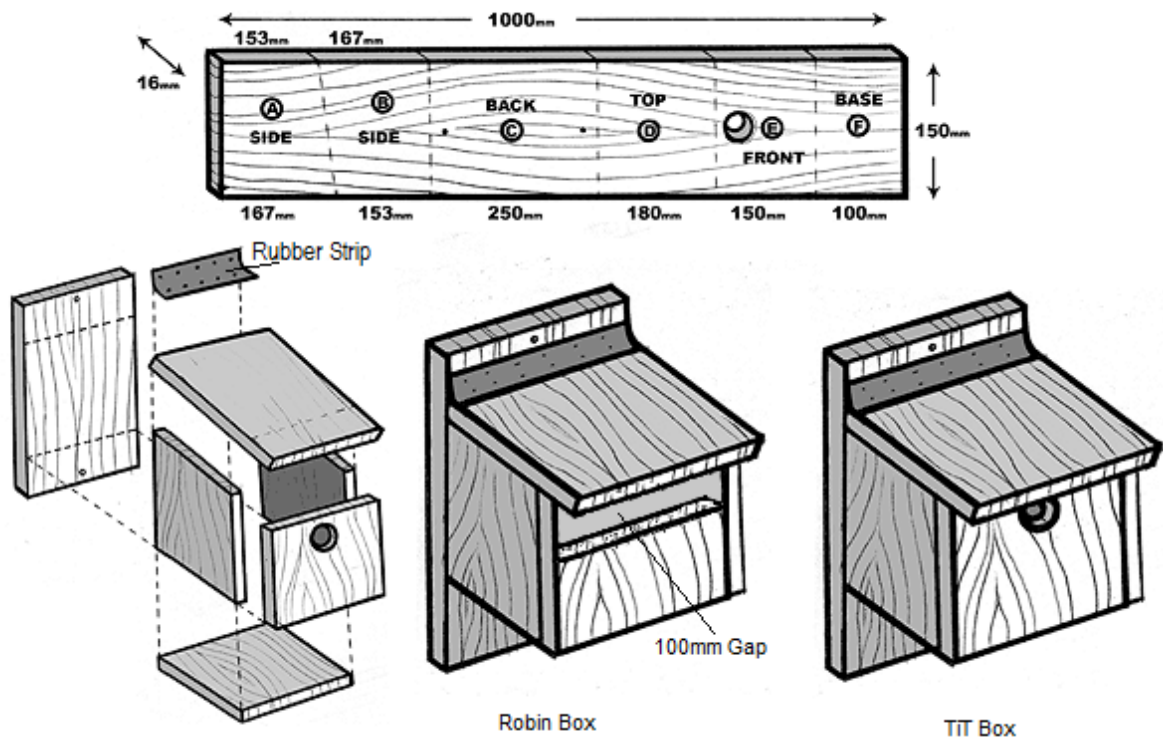

Eco-plate Hedgehog House



Eco-plate Hedgehog House



Specifications			
Width (cm)	Height (cm)	Length (cm)	Tunnel Length (cm)
60	35	46	36

Hedgehogs were once commonly seen in most UK gardens; now however a loss of hedgerows and agricultural intensification has resulted in a 30% reduction in populations in the last ten years. Hedgehogs are an important indicator species, and a decline in their numbers is often symptomatic of a far bigger problem with ecosystem health.

There are many ways that you can help support this species including providing them a home which is predator proof, secure home.

This hedgehog box was designed in collaboration with the Egelstichting (the Dutch Hedgehog protection society). This box is made of Eco-plate, a material similar in density to plywood, but produced from recycled car seats sourced from reputable suppliers, and grown from native stock.

This environmentally friendly material is weather resistant and very durable. The entrance tunnel is hidden inside the house to make it more difficult for predators to reach hedgehogs inside the house.

To make it habitable, part-fill the nest chamber with dried leaves. Place the box in a secluded corner and cover with soil or leaves to boost the chances of the box being used.

It would give a hedgehog daytime shelter between April and October, and will also allow them the space to hibernate during harsh winter months between November and mid-March.

The lid can be easily removed for cleaning, however, do not disturb the box while it is occupied.

APPENDIX 10: Hedgehog Highway.

Why do hedgehogs need holes in fences?

Hedgehogs travel around one mile every night through our parks and gardens in their quest to find enough food and a mate.

One of the main reasons hedgehogs are struggling in Britain is because our fences and walls are becoming more and more secure, reducing the amount of land available to them.

We can make their life a little easier by removing the barriers within our control hedgehogs can travel 2km (one mile) in a single night as they search for food and shelter, but sadly our garden fences and walls limit their movement.

Making small 13cm **hedgehog highways** through fences and walls, would allow hedgehogs to safely pass through into our gardens, and are a vital way to safeguard the future of the species.

Hedgehog Highways

A 13cm-by-13cm square hole is sufficient for any hedgehog to pass through, no matter what the wall or fence is made from. This will be too small for pets and dogs to pass through to pursue hedgehogs.



- Remove a brick from the bottom of the wall.
 - Cut a small hole in your fence if there are no gaps.
- Dig a channel underneath your wall, fence or gate, to obtain enough depth.





- A 13 cm diameter circular hole through brickwork creates a tunnel.



- Similarly, a 13cm diameter drain pipe would suffice through vertical fencing

If you are feeling particularly ambitious then the ideal option would be to swap your walls and fences for hedges. This would provide shelter, food and a route into an out of your garden, not to mention the benefits it would bring to other wildlife such as birds and bees.

Label your Hedgehog Highway

A “hedgehog Highway” label cut from recycled plastic, can be pinned above your hedgehog hole to ensure it is not blocked by anyone accidentally.

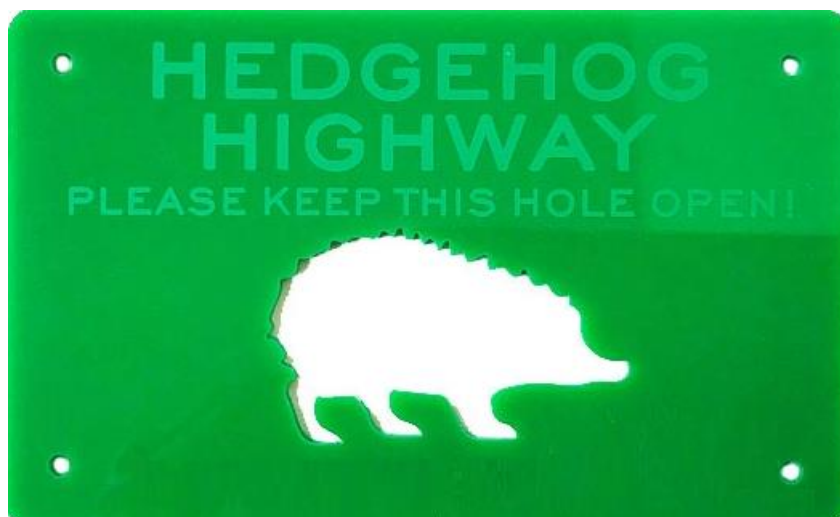

APPENDIX 11: Bats and Lighting.

The detailed lighting plan on-Site should be functional and directional and in line with current guidance (BCT and ILP, 2018). Habitat retained, enhanced or planted for roosting, foraging and/or commuting bats will need to be considered within a suitable lighting plan in order to be used by bats. Where designing with bats in mind:

- Light emitting diodes (LED) should be used, as these typically feature no UV component and as a result are less attractive to invertebrates and less disturbing to bats;
- Only luminaires with 0 % upward light ratio should be used and fitted on the horizontal to avoid excessive up-lighting, back lighting and light spill onto boundary hedgerows and trees;
- A warm white spectrum (ideally under 2700 Kelvin) should be used in order to reduce blue light component, therefore reducing the number of invertebrates attracted to the lights;
- Internal luminaires can be recessed where installed in proximity to windows to reduce glare and light spill;
- The use of specialist bollard or low-level downward directional luminaires to retain darkness above can be considered, although this has certain drawbacks and should only be used as directed by a lighting professional;
- Column heights should be carefully considered to minimise light spill;
- Any external security lighting should be set on motion-sensors and short (e.g., 1 minute) timers;
- Luminaires should feature peak wavelengths higher than 550nm to avoid the component of light most disturbing to bats;
- As a last resort, accessories such as baffles, hoods or louvres can be used to reduce light spill and direct it only to where it is needed;
- Where habitat needs to be unlit (e.g., important foraging and commuting corridors/roost sites), illuminance should be below 0.2 lux on the horizontal plane and below 0.4 lux on the vertical plane.