

This drawing is to be read in conjunction with all relevant Architect, consultants' and specialists' drawings and specifications. The Architect is to be notified of any discrepancies before proceeding. Do not scale from this drawing. All dimensions and levels are to be checked on site. This drawing is subject to copyright. All work carried out before Planning and Building Permission has been granted is at the contractor's risk.

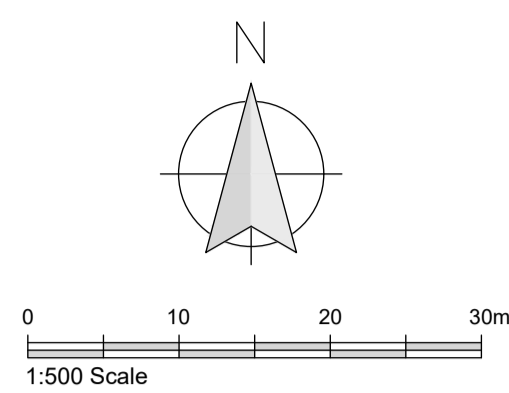

Client
Mr David Haigh

Job Title
**Foxfields Country Hotel
Whalley Road
Billington
BB7 9HY**

Drawing Title
Existing Site Plan

Scale	Date	Drawn
1:500 @ A1	OCT 2026	CA

spa
SUNDERLAND PEACOCK ARCHITECTS
SUNDERLAND PEACOCK & ASSOCIATES LTD.
HAZELMERE, PEARLICO ROAD, CLITHEROE
LANCASHIRE, BB7 2AG
T 01200 423178 F 01200 427328
E info@sunderlandpeacock.com
www.sunderlandpeacock.com

7337 -S01