

EXISTING EXTERNAL WALLS
U-Value = 0.30 W/m²K

Existing 450mm thick stone walls
New 25 x 47mm treated timber battens.
62.5mm Unilin XT/TL-MF insulation with integral vapour control layer.
12.5mm Gyproc plasterboard with a 3mm skim finish.

EXISTING ROOF - CEILING LEVEL
U-Value = 0.16 W/m²K

Existing roof covering - slates on timber treated battens on nilvent breathable membrane.
Existing timber ceiling joists assumed 100 x 38mm at 400mm centres. ISOVER spacerover cross-laid over joists - 170mm and 100mm between joists. 12.5mm Gyproc Wallboard below with 3mm plaster skim coat.

LINTELS

Existing timber lintels to be propped and carefully removed.
New timber lintels with a minimum end bearing of 150mm, set up in lime mortar and wedged tight to stonework above. Stone work above lintel to then be repair and repointed in hydraulic lime mortar and brushed off with a stiff bristle brush.

REPLACEMENT WINDOWS

U-Value 1.4 - 1.6 W/m²K
Timber windows with concealed trickle vents and bi-folding, to meet BS 4873. Colour to be determined by the Client.
Double glazed (24mm): 4mm - 16mm - 4mm, Low E=0.05, Argon filled.
All openings to have vertical DPC damcore or similar. To be installed with a perimeter gap between 5-10mm to allow for thermal expansion (up to 15mm for openings wider than 3.0m).
All new windows and external doors to have trickle vents - see background ventilation note.

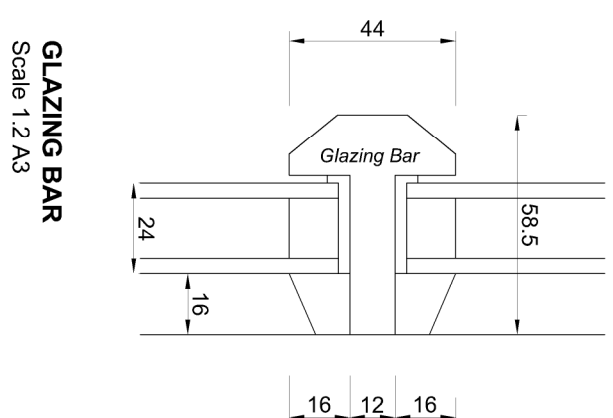
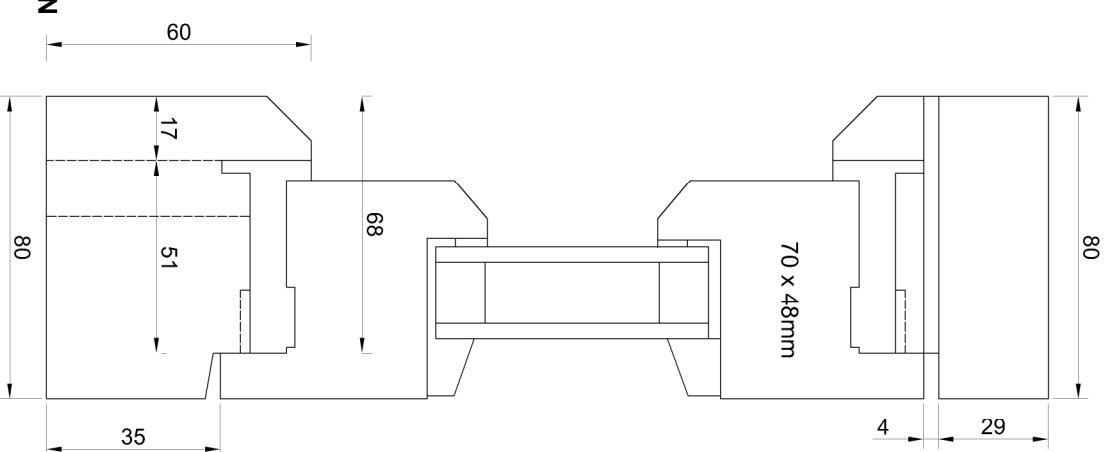

WINDOW SECTION
Scale 1:2 A3 -Two openers side by side

WINDOW SECTION
Scale 1:2 A3
One opener with one fixed to the side

Fire escape windows to habitable rooms to have an unobstructable openable area that is at least 0.33m² and at least 450mm high and 450mm wide. Openable window cill to be between 800mm (minimum) and 1100mm (maximum) from finished floor level.
Glazing 800mm from floor level, or 1500mm from floor level in doors or 300mm either side to be safely glazing as BS EN 12600, (i.e laminated or toughened glass).
All timber window frame painted White as existing.

INDICATIVE SECTION
SCALE 1:20 A3

WINDOW SECTION
Scale 1:2 A3

GLAZING BAR
Scale 1:2 A3

BRAMLEY - PATE + PARTNERS
Chartered Architects - Telephone (01772) 335357

Ivy Cottage, 15 Town End, Slaidburn, Clitheroe BB7 3EP For Slaidburn Estate C/O John Forrester	23 04 2026
Renovation of existing dwelling	Job No 2093
DETAILS	PL 00 02