

SURFACE TO BE REINSTATED AS PER EXISTING FINISHES OR TO ARCHITECTS' / ENGINEERS' SPECIFICATION FOR PROPOSED EXTERNAL WORKS.

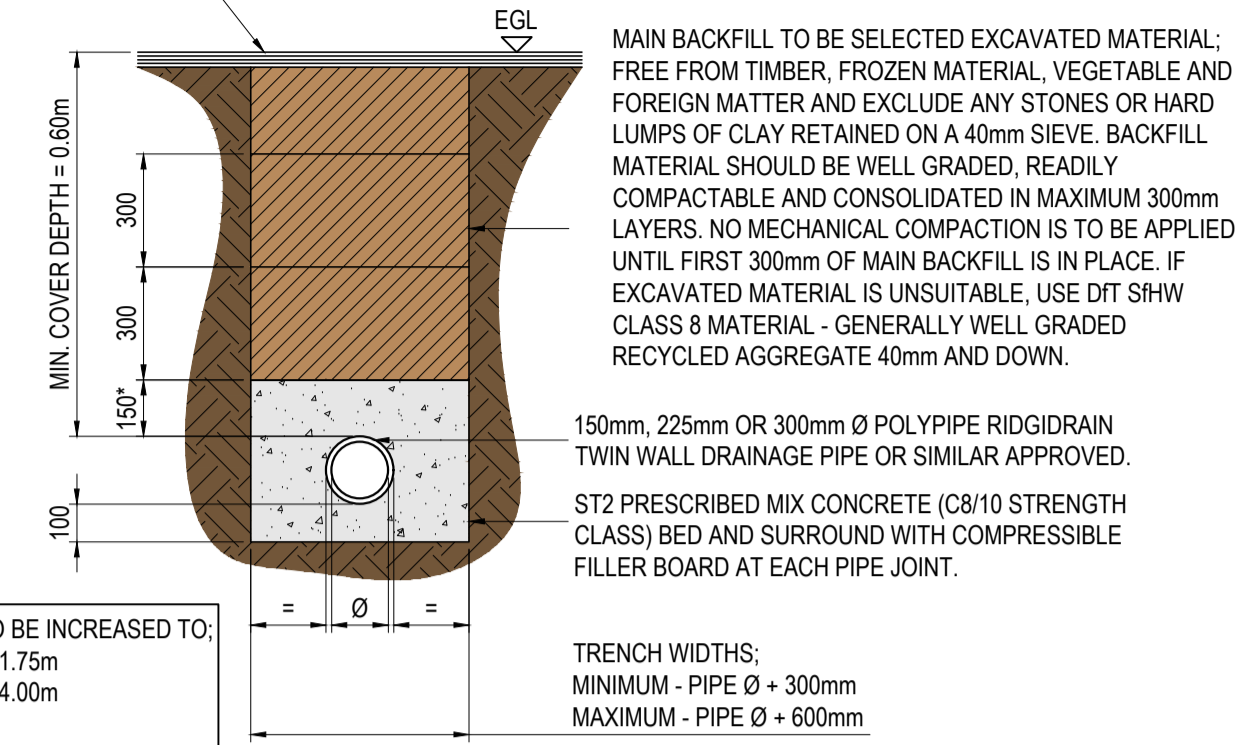

**TYPE Z - TWIN WALL PLASTIC PIPE TRENCH & BEDDING DETAIL FOR PAVED/TRAFFICKED AREAS WITH LESS THAN 1.20m COVER DEPTH TO PIPE**  
SCALE 1:20

NOTE! CONTRACTOR IS TO NOTIFY SLEATER & WATSON IF TRENCH FORMATION HAS LITTLE BEARING STRENGTH (SOFT GROUND, RUNNING SAND, ETC.) AND AN IMPROVED BEDDING CONSTRUCTION SHALL BE SPECIFIED.

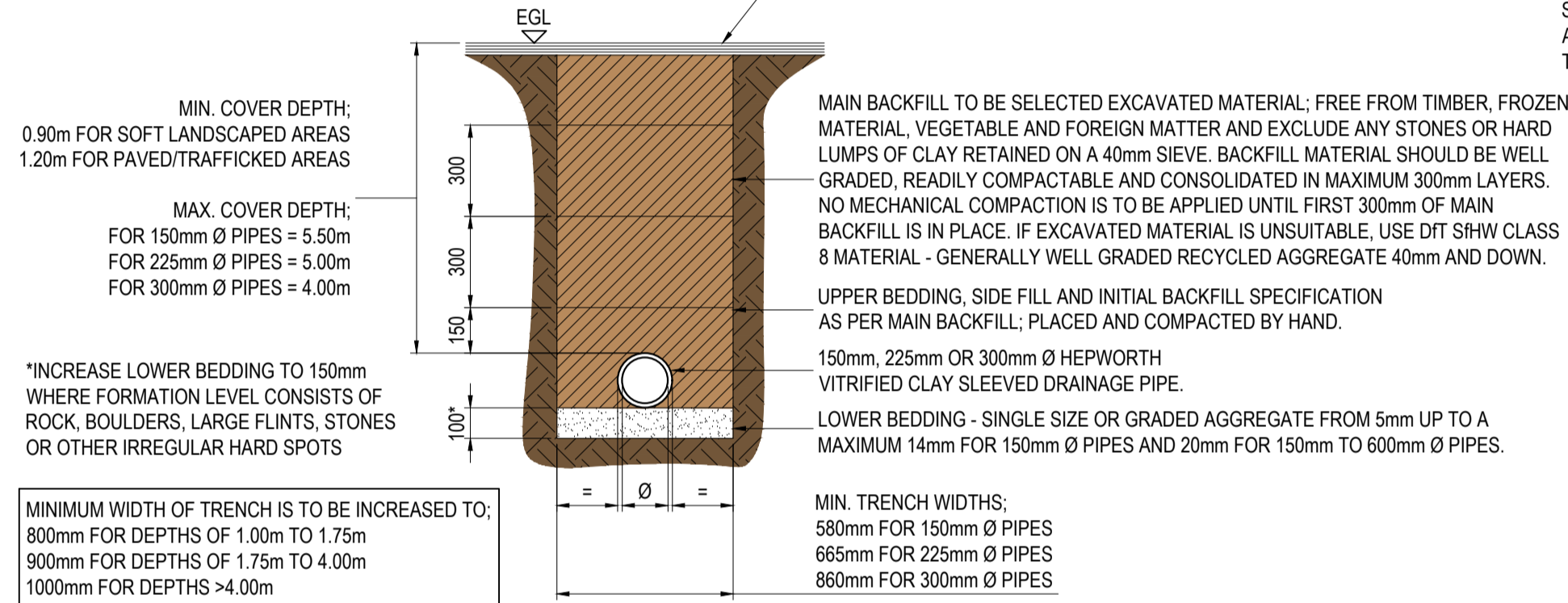

**TYPE N - CLAY PIPE TRENCH & BEDDING DETAIL FOR SOFT LANDSCAPED AREAS AND PAVED/TRAFFICKED AREAS WITH 1.20m+ COVER DEPTH TO PIPE**  
SCALE 1:20

SURFACE TO BE REINSTATED AS PER EXISTING FINISHES OR TO ARCHITECTS' / ENGINEERS' SPECIFICATION FOR PROPOSED EXTERNAL WORKS.

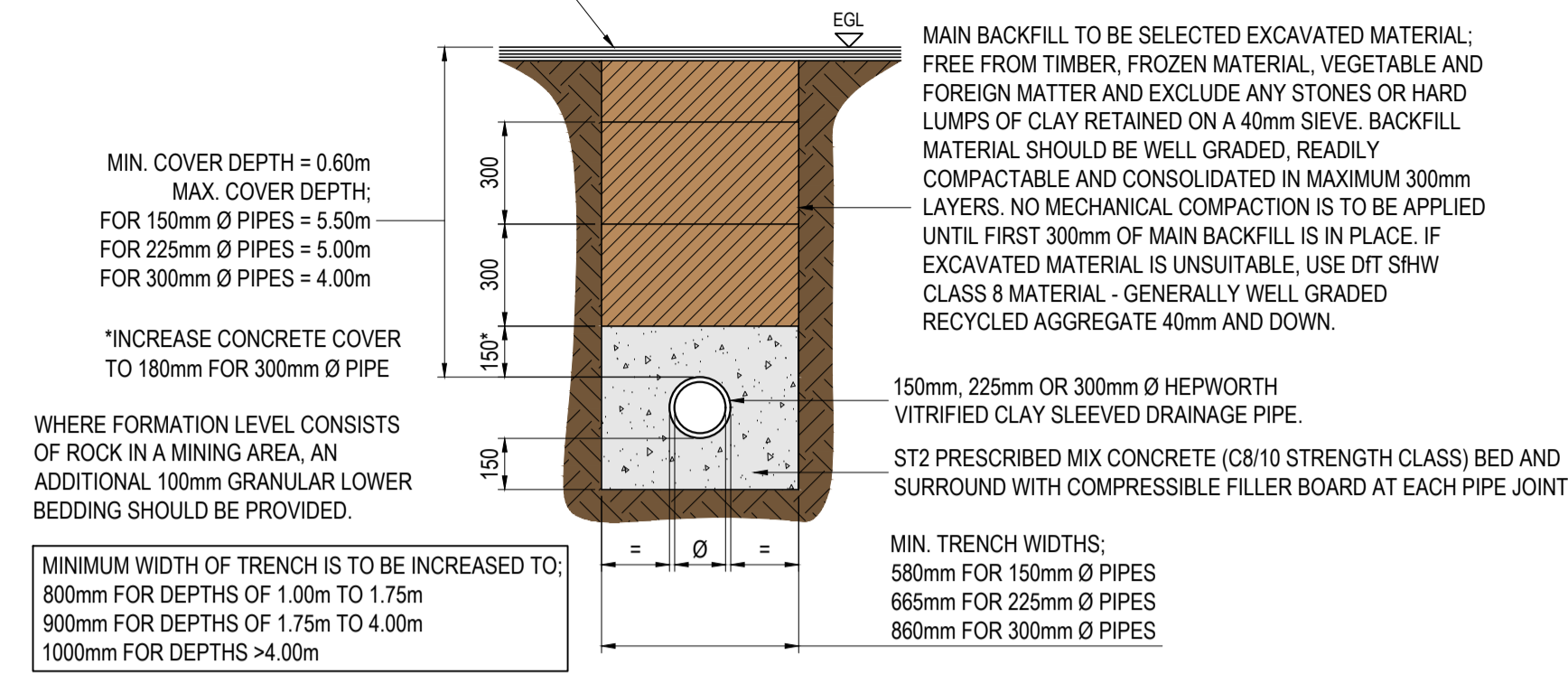

**TYPE Z - CLAY PIPE TRENCH & BEDDING DETAIL FOR PAVED & TRAFFICKED AREAS WITH LESS THAN 1.20m COVER DEPTH TO PIPE**  
SCALE 1:20

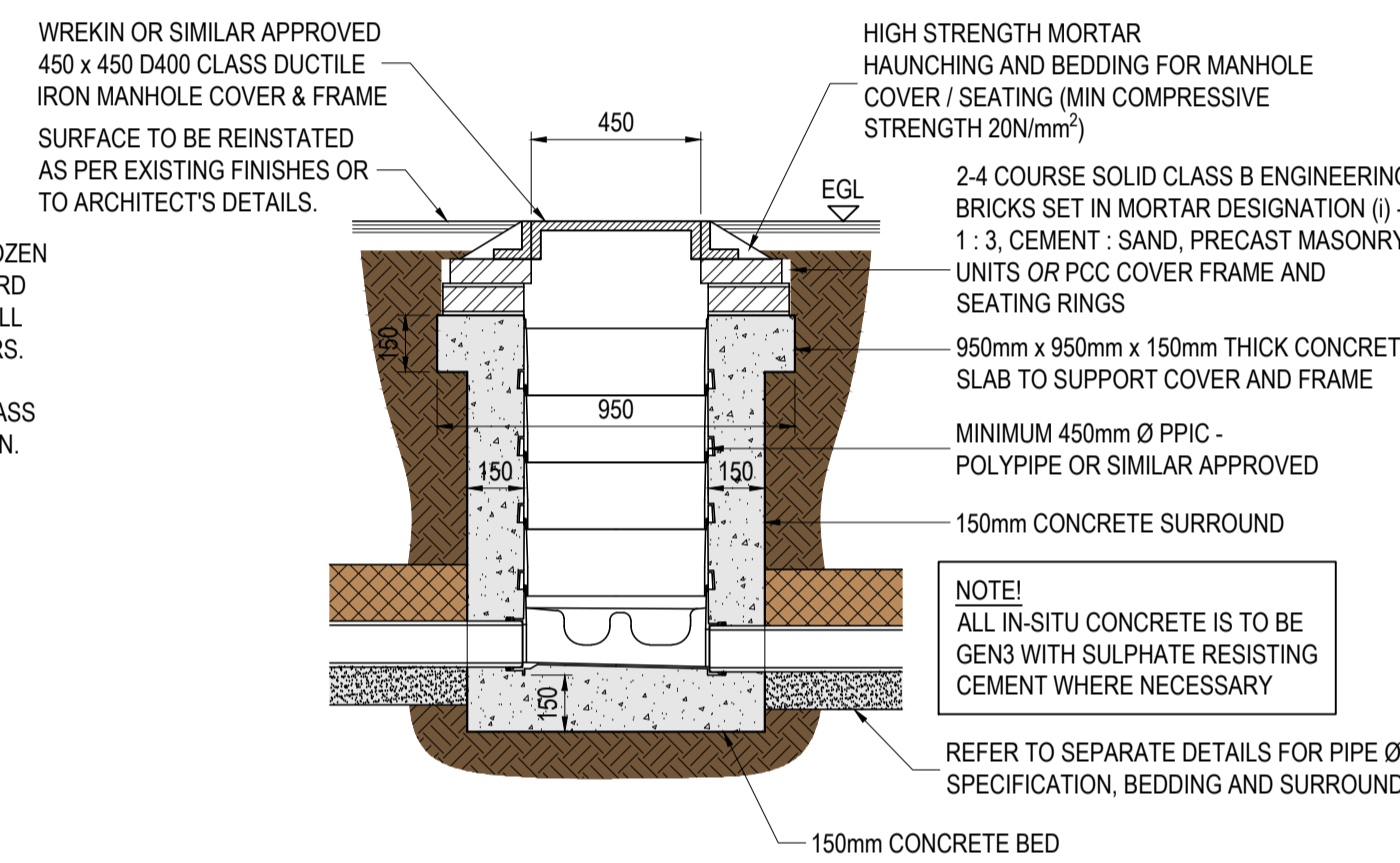

**TYPICAL SECTION THROUGH POLYPROPYLENE INSPECTION CHAMBER UP TO 1.0m DEEP**  
SCALE 1:20

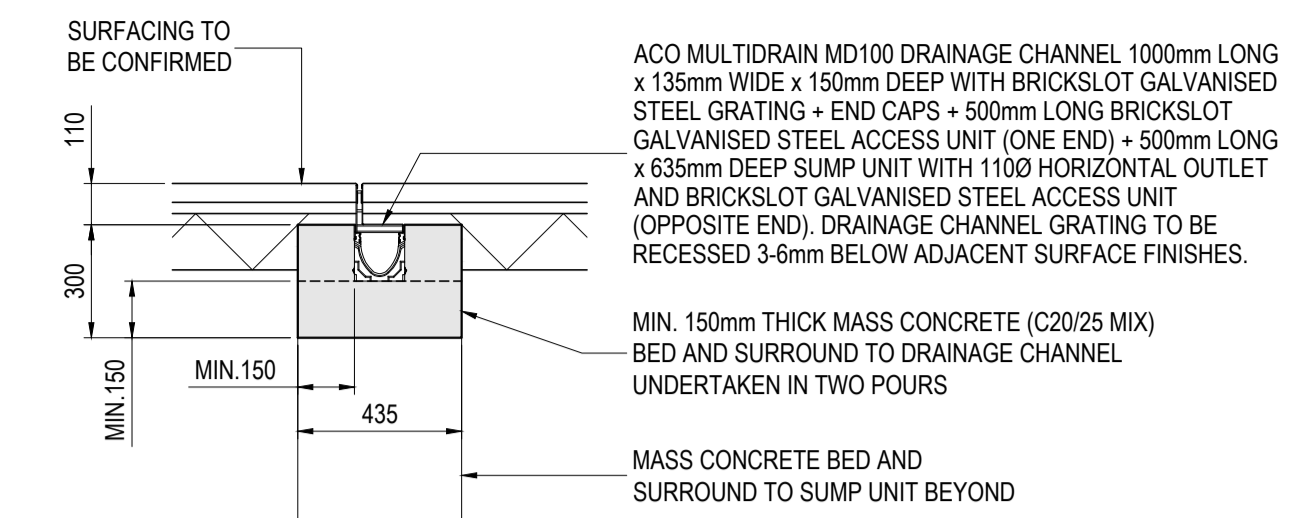

**TYPICAL SECTION THROUGH BRICKSLOT DRAINAGE CHANNEL TO PEDESTRIAN AREAS**  
SCALE 1:20

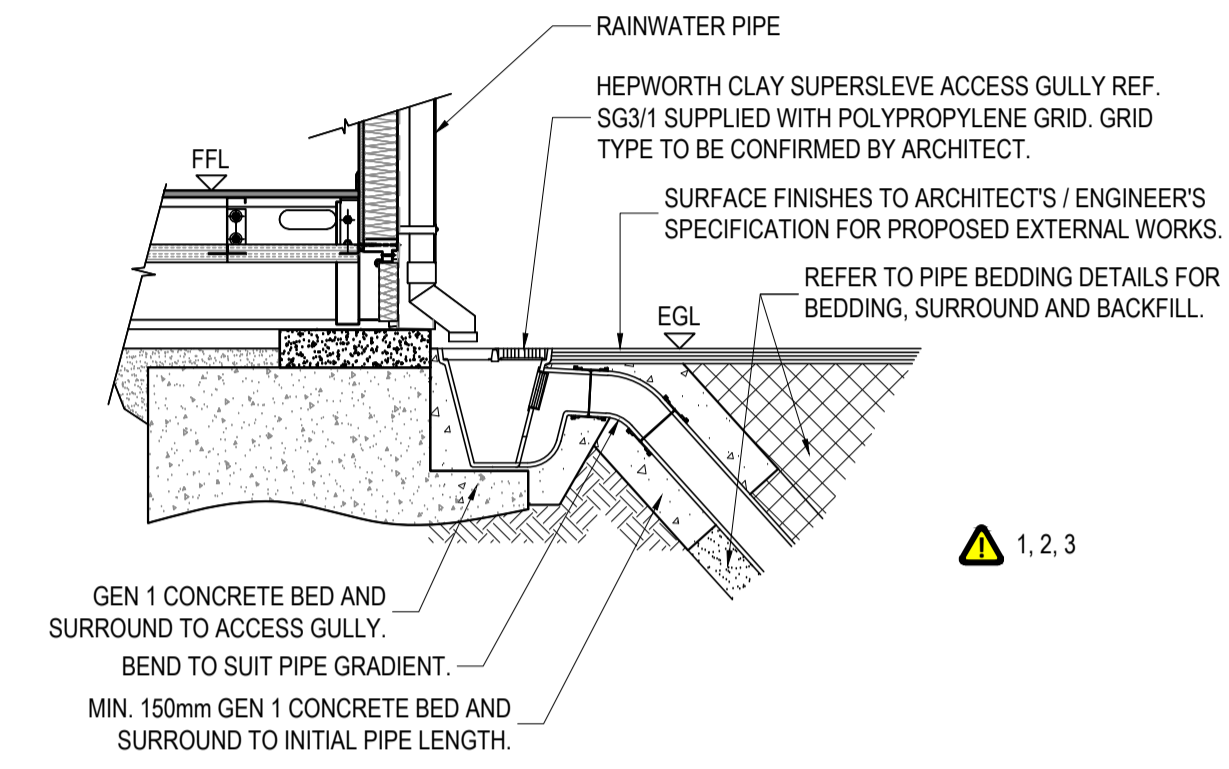

**TYPICAL ACCESS GULLY DETAIL (100mm Ø OUTLET)**  
SCALE 1:20

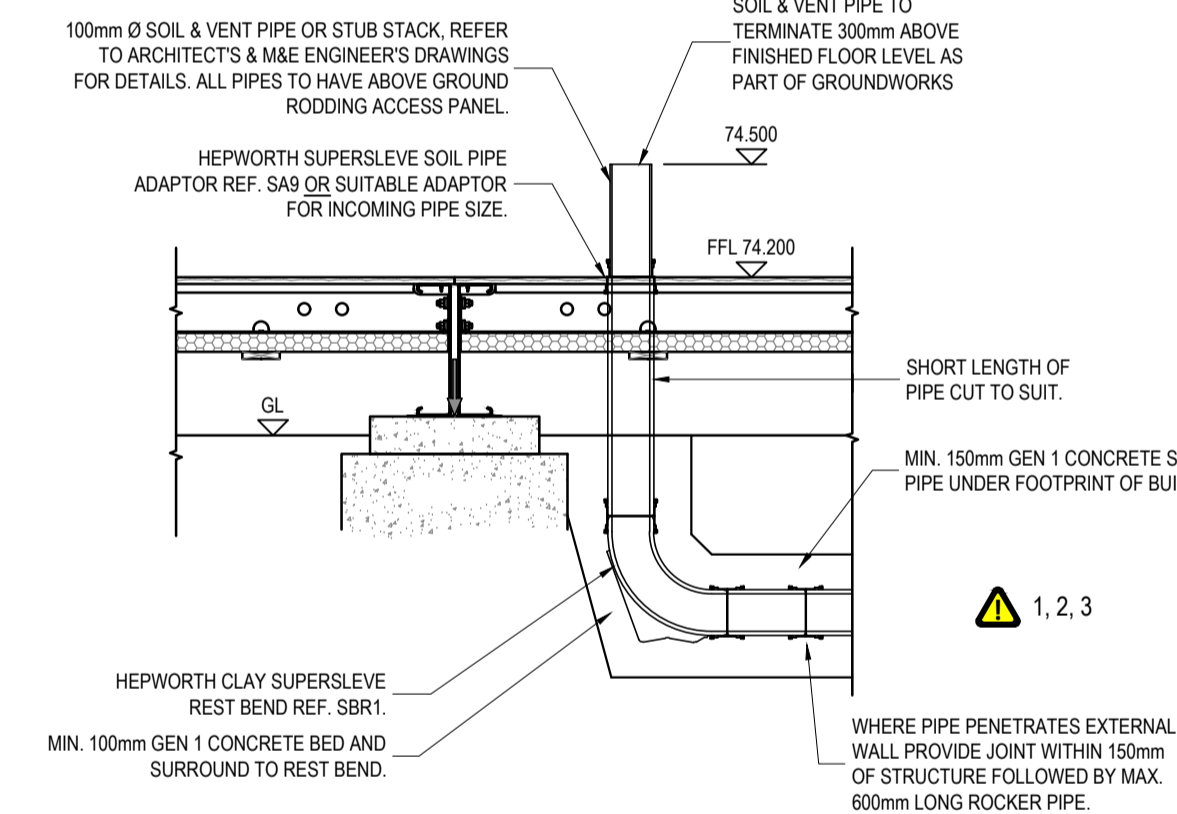

**TYPICAL SOIL & VENT OR STUB STACK TO 100mm Ø REST BEND CONNECTION DETAIL**  
SCALE 1:20

**GENERAL NOTES**

- THIS DRAWING IS TO BE READ IN CONJUNCTION WITH ALL RELEVANT SLEATER & WATSON LLP DRAWINGS AND SPECIFICATIONS ALONG WITH ALL ARCHITECTURAL AND MECHANICAL & ELECTRICAL ENGINEERING CONTRACT DOCUMENTS. WHERE 'DWG', 'REVIT' AND/OR 'IFC' FILES ARE SUPPLIED, THESE ARE FOR COLLABORATION WITH OTHER CONSULTANTS' INFORMATION AND SHOULD NOT BE USED FOR CONSTRUCTION PURPOSES BY THE CONTRACTOR. SUB-CONTRACTORS OR CLIENT, ONLY THE INFORMATION PROVIDED IN HARD COPY OR PDF FORMAT DRAWINGS IS TO BE RELIED UPON FOR ACCURACY.
- THE MATERIALS AND WORKMANSHIP OF ALL RELEVANT OPERATIONS SHALL COMPLY WITH THE RECOMMENDATIONS SET IN CURRENT BRITISH STANDARDS AND CODES OF PRACTICE.
- THE CONTRACTOR SHALL BE SOLELY RESPONSIBLE FOR THE DESIGN AND CONSTRUCTION OF ALL THE TEMPORARY WORKS, PROPPING AND SHORING.
- THE CONTRACTOR SHALL INFORM SLEATER AND WATSON IMMEDIATELY OF ANY VARIATIONS IN THE EXISTING CONSTRUCTION THAT NOTED ON THE DRAWINGS.
- ALL WORK IS TO COMPLY WITH ALL RELEVANT HEALTH AND SAFETY LEGISLATION AND REGULATIONS.
- ALL DIMENSIONS ARE SHOWN IN MILLIMETRES UNLESS NOTED OTHERWISE. DIMENSIONS MUST NOT BE SCALED. USE ANNOTATED DIMENSIONS ONLY.
- ALL DIMENSIONS ARE TO BE CHECKED ON SITE BY THE CONTRACTOR PRIOR TO CONSTRUCTION.
- ALL LEVELS ARE SHOWN IN METRES AND RELATE TO ORDNANCE DATUM.
- DRAINAGE DESIGN AND CONSTRUCTION TO BE IN ACCORDANCE WITH: BUILDING REGULATIONS APPROVED DOCUMENT H BS EN 12258 - GRAVITY DRAINAGE SYSTEMS INSIDE BUILDINGS. BS EN 752 - DRAIN AND SEWER SYSTEMS OUTSIDE BUILDINGS. BS EN 1810 - CONSTRUCTION AND TESTING OF DRAINS AND SEWERS. SEWERS FOR ADOPTION - FTH EDITION.
- THE CONTRACTOR IS TO CHECK THE CONDITION OF ALL EXISTING DRAINAGE DETAILS TO CONFIRM THEY ARE IN GOOD WORKING ORDER AND THE LEVELS SHOWN ON THIS DRAWING ARE ACCURATE PRIOR TO COMMENCEMENT OF ANY WORKS OR DURING WEEK ONE OF THE CONTRACT PROGRAMME. SLEATER & WATSON LLP ENGINEER TO BE NOTIFIED OF ANY DISCREPANCIES.
- ALL ARISING THAT ARE TO BE REMOVED FROM SITE SHALL BE DISPOSED OF AT A LICENSED WASTE DISPOSAL SITE. WHERE NECESSARY TEST CERTIFICATES FOR ARISING CONTAINING CONTAMINANTS SHOULD BE SUBMITTED TO THE LICENSED WASTE DISPOSAL SITE FOR APPROVAL AND ACCEPTANCE AS SOON AS IS PRACTICALLY POSSIBLE.
- ALL PROPOSED DRAINAGE DETAILS ARE TO BE CONSTRUCTED TO THE COMPLETE SATISFACTION OF THE PROJECT'S BUILDING CONTROL OFFICER.
- ALL SURFACE WATER INTERNAL BELOW GROUND DRAINAGE AND EXTERNAL DRAINAGE UP TO AND INCLUDING 300mm DIAMETER IS TO BE POLYPIPE RIDGDRAIN TWIN WALL HDPE PIPEWORK OR SIMILAR APPROVED IN MAXIMUM 3.0m LONG LENGTHS.
- ALL POLYPIPE BELOW GROUND DRAINAGE IS TO BE CONNECTED VIA POLYPIPE DOUBLE SOCKET COUPLINGS WITH EPDM SEALS REFERENCED - CRD100-SRD100 FOR 100Ø, CRD150-SRD150 FOR 150Ø, CRD225-SRD225 FOR 225Ø AND CRD300-SRD300 FOR 300Ø.
- ALL SURFACE WATER INTERNAL BELOW GROUND DRAINAGE WITH COVER UP TO 1.20m IS TO BE BEDDED AS TYPE Z. ST2 PRESCRIBED MIX CONCRETE BED AND SURROUND WITH COMPRESSIBLE FILLER BOARD AT PIPE JOINTS.
- ALL SURFACE WATER EXTERNAL BELOW GROUND DRAINAGE WITH COVER EXCEEDING 1.20m IS TO BE BEDDED AS TYPE S.
- ALL FOUL WATER INTERNAL BELOW GROUND DRAINAGE AND EXTERNAL DRAINAGE UP TO AND INCLUDING 300mm DIAMETER IS TO BE HEPWORTH SUPERSLEEVE VITRIFIED CLAY PIPEWORK OR SIMILAR APPROVED TO BS EN 255-1.
- EXCAVATIONS, BACKFILLING AND REINSTATEMENT WITHIN EXISTING PUBLIC AND PRIVATE HIGHWAYS SHALL BE CARRIED OUT IN ACCORDANCE WITH THE DTI AND HAUC NEW ROADS AND STREET WORKS ACT 1991 - SPECIFICATION FOR THE REINSTATEMENT OF OPENINGS IN HIGHWAYS.
- ALL DRAINS ARE TO BE LAID TO THE GRADIENTS INDICATED ON PLAN. IN THE ABSENCE OF THIS INFORMATION THE FOLLOWING MINIMUM GRADIENTS CAN BE ADOPTED:  
SURFACE WATER 150mm Ø = 1 IN 150  
SURFACE WATER 225mm Ø = 1 IN 200
- ALL CONCRETE MANHOLES ARE TO BE FORMED USING STANTON BONNA CONCRETE RINGS, COVER SLABS AND REDUCING SLABS (WHERE APPLICABLE) OR SIMILAR APPROVED TO BS EN 1917 AND BS 5911-3. FOR CONSTRUCTION AND SIZES REFER TO DETAILS DRAWING.
- ALL MANHOLE COVERS ARE TO BE ORIENTATED TO SUIT EXTERNAL FEATURES, I.E. BUILDINGS, KERB LINES, BLOCK PAVING (IF PRESENT), ETC.
- ALL DRAINAGE CHANNELS, ASSOCIATED GULLY / SUMP UNITS AND GRATINGS ARE TO BE INSTALLED IN ACCORDANCE WITH MANUFACTURER'S DETAILS. DRAINAGE CHANNEL BED AND SURROUND SHALL BE CONSTRUCTED IN ACCORDANCE WITH SLEATER & WATSON'S DETAIL DRAWINGS.
- THE ATTENUATION TANK IS TO BE WRAPPED IN A HIGH DENSITY POLYETHYLENE MEMBRANE. VISQUEEN GX GEOMEMBRANE x 1.0mm THICK MEMBRANE IS TO BE PROTECTED ON THE OUTSIDE BY A VISQUEEN GEOTEXTILE PROTECTION BLANKET OR VISQUEEN 3.0mm THICK HEAVY DUTY PROTECTION BOARD. THIRD PARTY VALIDATION IS TO BE UNDERTAKEN UPON THE COMPLETED TANKING MEMBRANE INSTALLATION PRIOR TO COMMENCEMENT OF BACKFILLING. A SUPPORTING VALIDATION REPORT IS TO BE PROVIDED BY THE THIRD PARTY.
- LOCATION OF THE VENT OUTLET TO THE ATTENUATION TANKS IS AS PER THE PLAN DRAWING OR IS TO BE AGREED WITH THE ARCHITECT/CLIENT.
- PRIOR TO CCTV SURVEY, THOROUGHLY FLUSH WITH WATER AND ROD ALL PIPELINES AND MANHOLES TO REMOVE ANY CONSTRUCTION DEBRIS, BACKFILL MATERIAL AND SILT. ANY DETRITUS PRESENT SHALL BE SAFELY DISPOSED OF WITHOUT DISCHARGING THEM INTO SEWERS OR WATERCOURSES.
- UPON COMPLETION OF THE PROPOSED DRAINAGE WORKS, THE CONTRACTOR IS TO ARRANGE FOR ALL SYSTEMS, INCLUDING INTERFACES WITH EXISTING DRAINAGE PIPES AND MANHOLES, TO BE CCTV SURVEYED. IN ADDITION, THE TWIN WALL HDPE INSTALLATIONS ARE TO BE LASER PROFILED TO RECORD THE OVALITY AND ANY DEFORMATION OF THE PIPEWORK. A SUBSEQUENT REPORT IS TO BE PROVIDED TO SLEATER & WATSON. IT IS FURTHER RECOMMENDED THAT LASER PROFILING IS UNDERTAKEN ON HDPE DRAINS BELOW HARD SURFACES PRIOR TO COMPLETION.

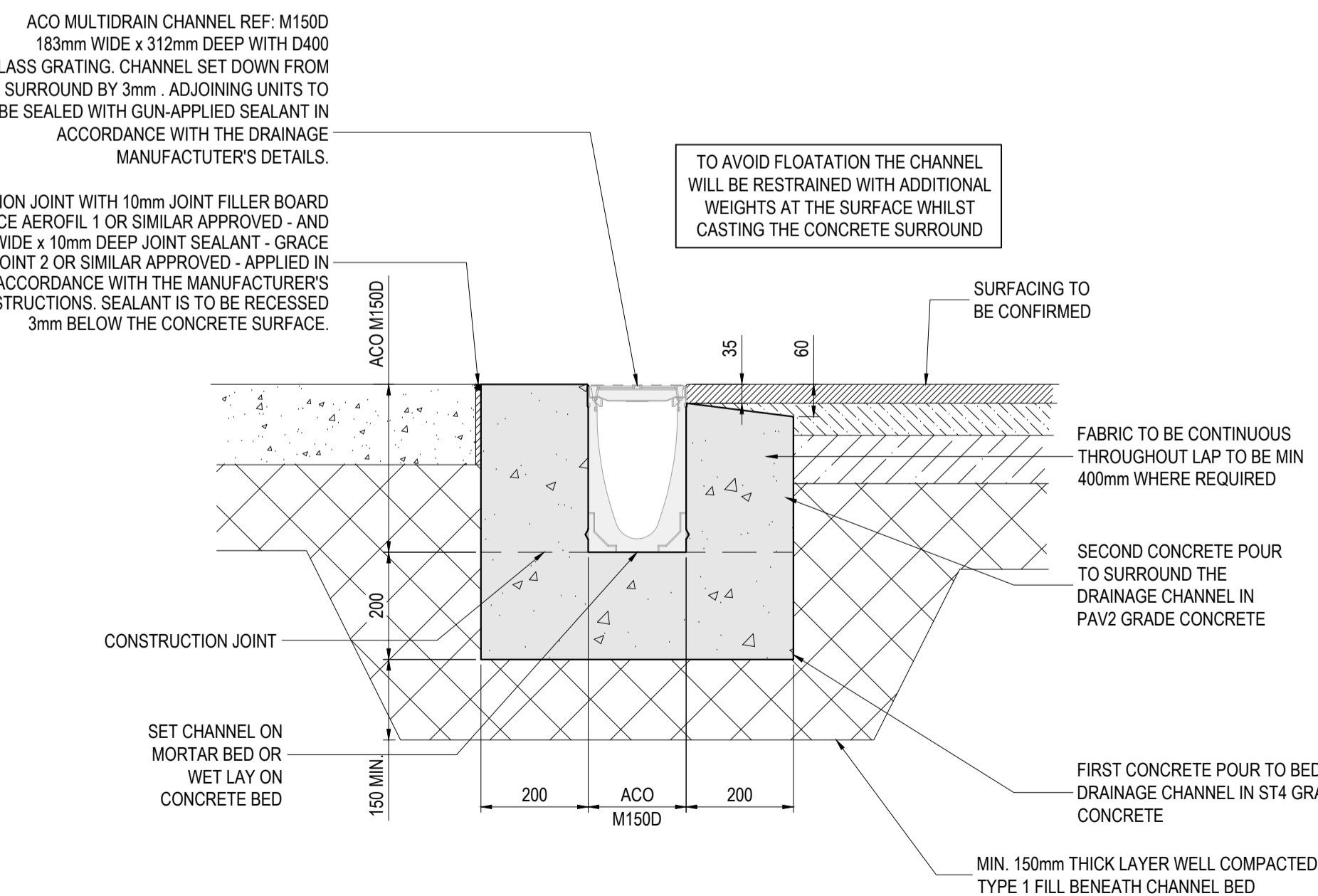

**TYPICAL SECTION THROUGH ACO M1500 DRAINAGE CHANNEL**  
SCALE 1:10

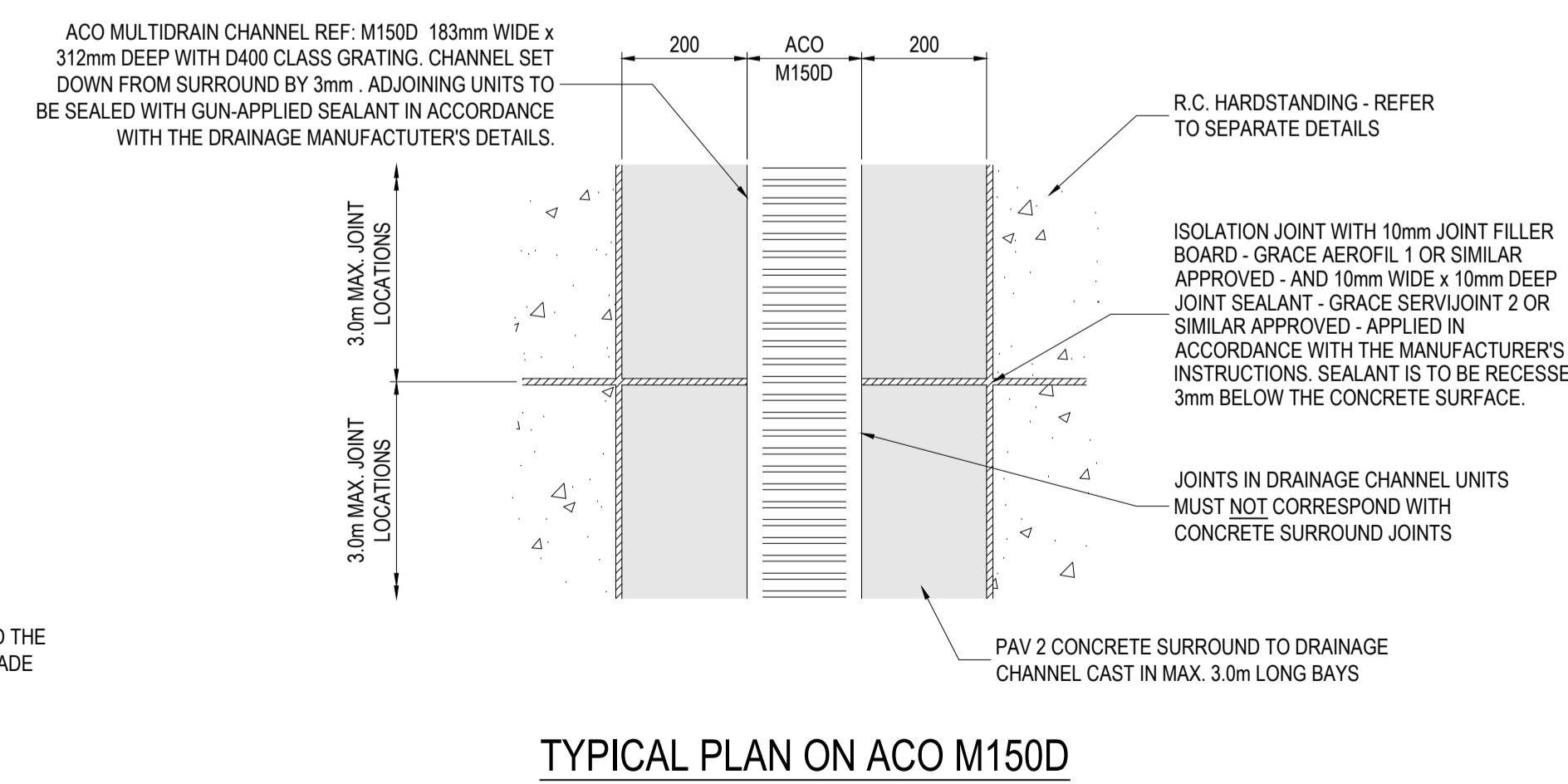

**TYPICAL PLAN ON ACO M1500 DRAINAGE CHANNEL**  
SCALE 1:10

DRAWING ISSUED FOR DISCHARGE OF PLANNING CONDITIONS

CONSTRUCTION (DESIGN AND MANAGEMENT) REGULATIONS 2015 - MANAGING H&S INFORMATION BOX FOR THE CONSTRUCTION AND MAINTENANCE OF THE PROJECT				
IN ADDITION TO THE HAZARDS AND RISKS NORMALLY ASSOCIATED WITH THE TYPE OF WORKS DETAILED ON THIS DRAWING, TAKE NOTE OF THE FOLLOWING SIGNIFICANT RISKS WHICH ARE NOT OBVIOUS, ARE UNUSUAL, OR LIKELY TO BE DIFFICULT TO MANAGE. IT IS ASSUMED THAT ALL WORKS ON THIS DRAWING WILL BE CARRIED OUT BY A COMPETENT CONTRACTOR WORKING, WHERE APPROPRIATE, TO AN APPROPRIATE METHOD STATEMENT.				
INDICATES A RESIDUAL RISK WARNING				
1.	AVOIDANCE OF EXISTING BURIED AND UNKNOWN UNDERGROUND SERVICES. BEFORE STARTING WORK, UNDERGROUND SERVICE PLANS SHOULD BE OBTAINED AND SERVICE SCANNING MUST BE COMPLETED BY THE CONTRACTOR.			
2.	CONTAMINATED OR UNSTABLE GROUND CONDITIONS.			
3.	THE DESIGN OF TEMPORARY WORKS, SUCH AS TRENCI SUPPORT, DE-WATERING, TEMPORARY PROPPING, ETC., WHICH MUST BE UNDERTAKEN BY A TEMPORARY WORKS DESIGNER.			

P1	PRELIMINARY ISSUE	14.05.26	MB
REV	AMENDMENTS	DATE	INTS
STATUS			
<b>PRELIMINARY</b>			
<b>Sleater &amp; Watson</b>			
Consulting Civil & Structural Engineers. Ribble House, Meanygate, Bamber Bridge, Preston, PR5 6UP Telephone: 01772 821044 E-mail: admin@sleaterwatson.co.uk Website: www.sleaterwatson.co.uk			
CLIENT			
<b>BAE SYSTEMS</b>			
PROJECT			
<b>MODULAR BUILDING, (CEB REPLACEMENT), BAE SYSTEMS, SAMLESBURY.</b>			
TITLE			
<b>DRAINAGE DETAILS SHEET 2</b>			
DRAWN	CHECKED	DATE	PROJECT No.
MB	GJW	MAY, 2026	225/011
SCALE@A1	AS SHOWN		
ORG No.			
<b>CEB-SAW-XX-00-52-DR-C-5221-S0-P1</b>			